

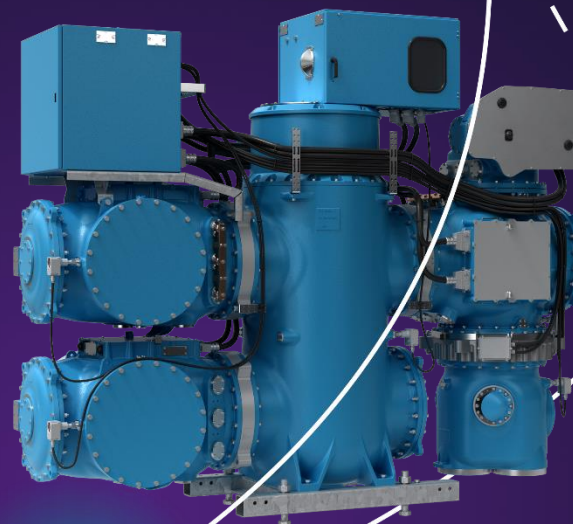







8VN1 Blue GIS™ up to 145 kV

Vacuum interrupting technology and clean air
for insulation with Zero F-gases

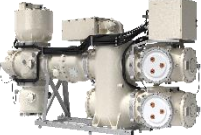

Gas-insulated switchgear 8VN1 Blue GIS™ up to 145 kV / 50 kA

Product portfolio 72.5 kV – 550 kV

Product line	8VM1	8VM3	8VN1	8DN8		8DN9	8DQ1		
Solution									
Rated voltage (up to)	72.5 kV	72.5 kV	145 kV	145 kV	170 kV	245 kV	420 kV (245 kV)	420 kV	550 kV
Rated short circuit-breaking current (up to)	25 kA	31.5 kA	50 kA	40 kA	63 kA	50 kA	63 kA (80 kA)	80 kA	63 kA
Rated current busbar (up to)	-	-	3150 A	3150 A	4000 A	4000 A	6300 A	6300 A	5000 A
Rated current feeder (up to)	1250 A	1250 A	3150 A	3150 A	4000 A	4000 A	5000 A	5000 A	5000 A
Interrupter technology	vacuum			self-compression principle					
Insulation medium	clean air			SF ₆					

Replacing SF₆ in high voltage

We are doing it with clean air



Proven technology

Already 1,500 units with more than 20 million hours successfully in operation



Peak performance & safety

Highest switching performance, zero toxic by-products, fully compliant with IEC and ANSI/IEEE



GWP < 1

Clean air gives the equipment the lowest carbon footprint across its life cycle



Suitably sized

Our clean air units fit within the footprint of the SF₆ units they replace



Future-proof

Our Blue switchgear is the answer to the EU F-gas regulation GWP < 1

Siemens Energy welcomes the regulatory frame to cut CO₂ emissions for new installations:

Clean air insulation and vacuum switching technology is future-proof and not impacted by any restrictions or obligations with the revised EU F-gas regulation or expected PFAS restrictions!

Siemens Energy Blue has a clear Zero-compromise philosophy



Zero environmental impact

- Zero SF₆ and other F-gases
- Zero GHG emissions and Zero GWP
- Long lasting design (> 40 years) and circular materials



Zero impact on health & safety

- Zero toxic insulation gases
- Zero toxic decomposition products



Zero regulation & special handling

- Zero reporting & accounting of gases required
- Zero issues with current & potential F-gas regulation
- Zero special safety measures
- Zero gas disposal required at end of life



Zero compromise on performance

- Voltages from 72.5 to 145 kV
- Highest short-circuit switching capability with Zero degradation
- Full performance down to -60°C
- Maintenance-free interrupter unit („sealed for life“)

The Blue portfolio is based on game-changing technology: vacuum switching and clean air insulation

Clean air (N₂ + O₂) insulation



- Zero CO₂ emissions, lowest CO₂ footprint, GWP = 0
- Zero toxicity, highest stability, easiest gas handling
- Zero liquefaction at low temperatures -60° C
- Zero patent dependencies, multiple suppliers



Vacuum interruption

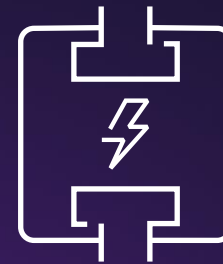

- Zero toxic decomposition products, hermetically tight
- Highest switching performance w/o degradation, scalable short-circuit current capabilities
- Zero maintenance (sealed for life)



Clean, safe and future-proof regarding F-gas and PFAS regulation!

The Blue portfolio comprises individual products & solutions, supporting our clients on their way to Zero

Up to 145 kV

Wind Tower and Offshore Blue GIS™

- 72.5 kV / 31.5 kA
- Optimized switchgear for application in wind turbines, with vacuum CB and clean air insulation



Blue Circuit Breaker™ Live Tank

- up to 145 kV / 40 kA
- World's first LT CB with vacuum interrupter and clean air insulation



Higher voltages (available)

Blue Clean Air GIB™

- 420 kV / 63 kA
- 245 – 400 kV = combined solution GIS + Blue GIB (30 – 65% less SF₆)



Blue GIS™

- 145 kV / 50 kA
- World's first 145 kV GIS switchgear with vacuum CB and clean air insulation
- Optimized footprint by using LPIT¹



Blue Circuit Breaker™ Dead Tank

- 145 kV / 63 kA
- World's first 145 kV DT vacuum CB with clean air insulation
- Same footprint as SF₆ product



Blue Circuit Breaker™ Live Tank²

- up to 420 kV / 63 kV
- World's first 420 kV LT breaker with clean air insulation
- Same footprint as SF₆ product



¹ Low Power Instrument Transformer

² available 2026

Gas-insulated switchgear 8VN1 Blue GIS™ up to 145 kV / 50 kA

Vacuum interrupter - development of product/production technology

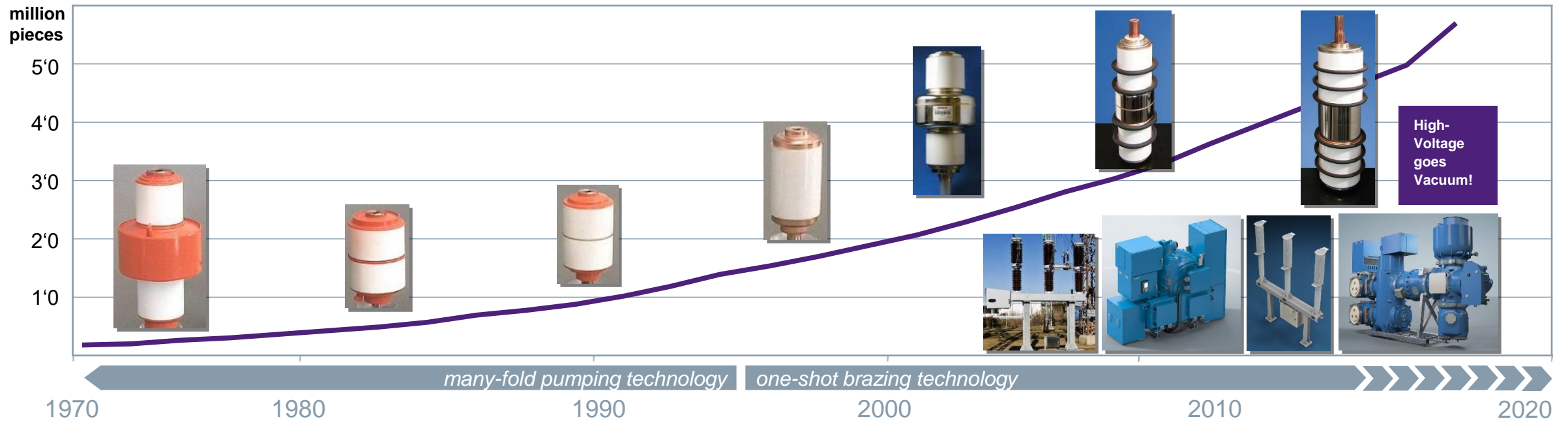

1971

First serial manufacturing of vacuum interrupters for contactors.

- More than 40 years of operational experience in the field of medium voltage applications
- More than 5.5 million vacuum interrupters delivered

2010

Introduction of prototypes for 72.5 kV

2016

Introduction of 145 kV portfolio with vacuum interrupter for up to 72.5 kV and up to 145 kV

New SE VI factory in Berlin – inhouse expertise and availability



Surface treatment

Clean room assembly

Final brazing

Test field



- Electropolishing => gold plating => supporting assemblies => fine cleaning
- To remove oil, loose soiling and any other particles => smoothing the surfaces and sharp edges

- Commissioning => pre-assembly => final assembly
- Assembly under clean room conditions with special clothing for the staff and supported by visual control system

- Brazing => batch dismantling => assembly bearing
- Automatic brazing of VI in high vacuum atmosphere at 800°C (20+ hours per batch)

- Diameter measurement => x-ray inspection => mechanical conditioning => electrical conditioning => resistance check => pressure check
- To control positioning of all parts in VI, compression of contact system, internal resistance and pressure

Gas-insulated switchgear 8VN1 Blue GIS™ up to 145 kV / 50 kA

Technical data (with Low Power Instrument Transformer)

Switchgear type	8VN1	
Rated voltage	up to	145 kV
Rated frequency		50 / 60 Hz
Rated short-duration power-frequency withstand voltage (1 min)	up to	275 kV
Rated lightning impulse withstand voltage (1.2 / 50 μs)	up to	650 kV
Rated continuous current - busbar	up to	3150 A
Rated continuous current - feeder / bus coupler	up to	3150 A
Rated short-circuit breaking current	up to	50 kA
Rated peak withstand current	up to	135 kA
Rated short-time withstand current (up to 3 s)	up to	50 kA
Leakage rate per year and gas compar TM ent (type-tested)		< 0.1 %
Driving mechanism of circuit-breaker		stored-energy spring
Rated operating sequence		O-0.3 s-CO-3 min-CO
		CO-15 s-CO
Interrupter technology		Vacuum
Insulation medium		Clean air
Weight of SF ₆ or other fluorinated greenhouse gases		0 kg
GWP Global Warming Potential		0
CO ₂ equivalent		0 kg
Rated filling pressure		0,8 MPa abs
Bay width common pole drive		1000 mm
Bay height, depth (depending on bay arrangement)		2900 mm x 3700 mm
Bay weight (depending on bay arrangement)		4.7 t
Ambient temperature range		-50 °C up to +55 °C
Installation		indoor / outdoor
First major inspection		> 25 years
Expected lifetime		> 50 years
Standards		IEC / IEEE
Other values on request		

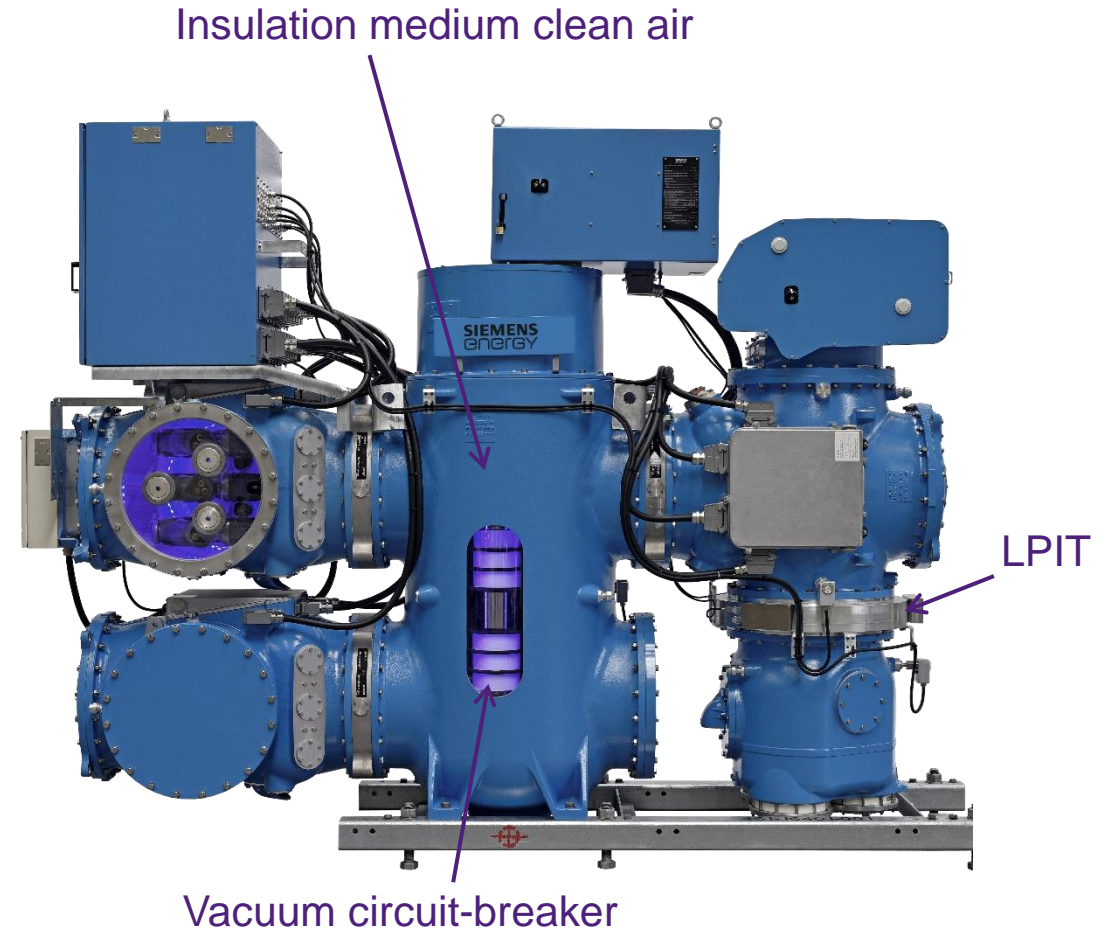

Gas-insulated switchgear 8VN1 Blue GIS™ up to 145 kV / 50 kA

Switchgear bay (with Low Power Instrument Transformer)

- 1 Integrated local control cubicle
- 2 Circuit-breaker with vacuum interrupter
- 3 Spring-stored-energy operating mechanism with circuit-breaker control unit (common drive)
- 4 Busbar I with disconnecter and earthing switch
- 5 Busbar II with disconnecter and earthing switch
- 6 Low Power Instrument Transformers (LPIT)
- 7 Outgoing module with disconnecter and earthing switch
- 8 Make-proof earthing switch (high speed)
- 9 Cable connection module

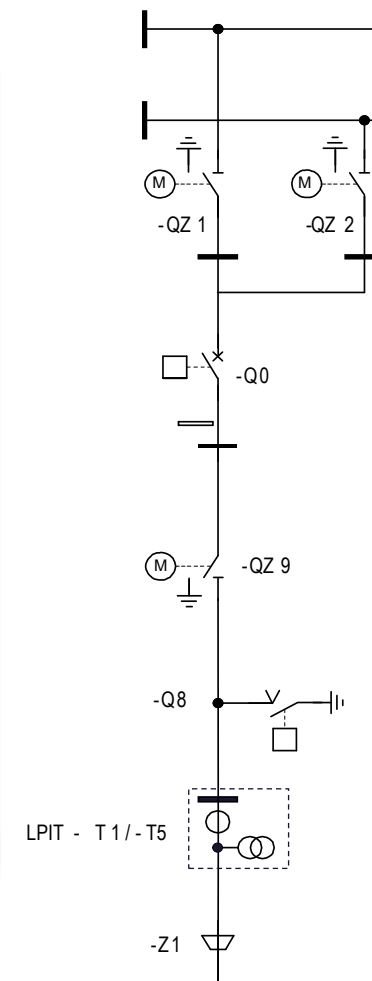
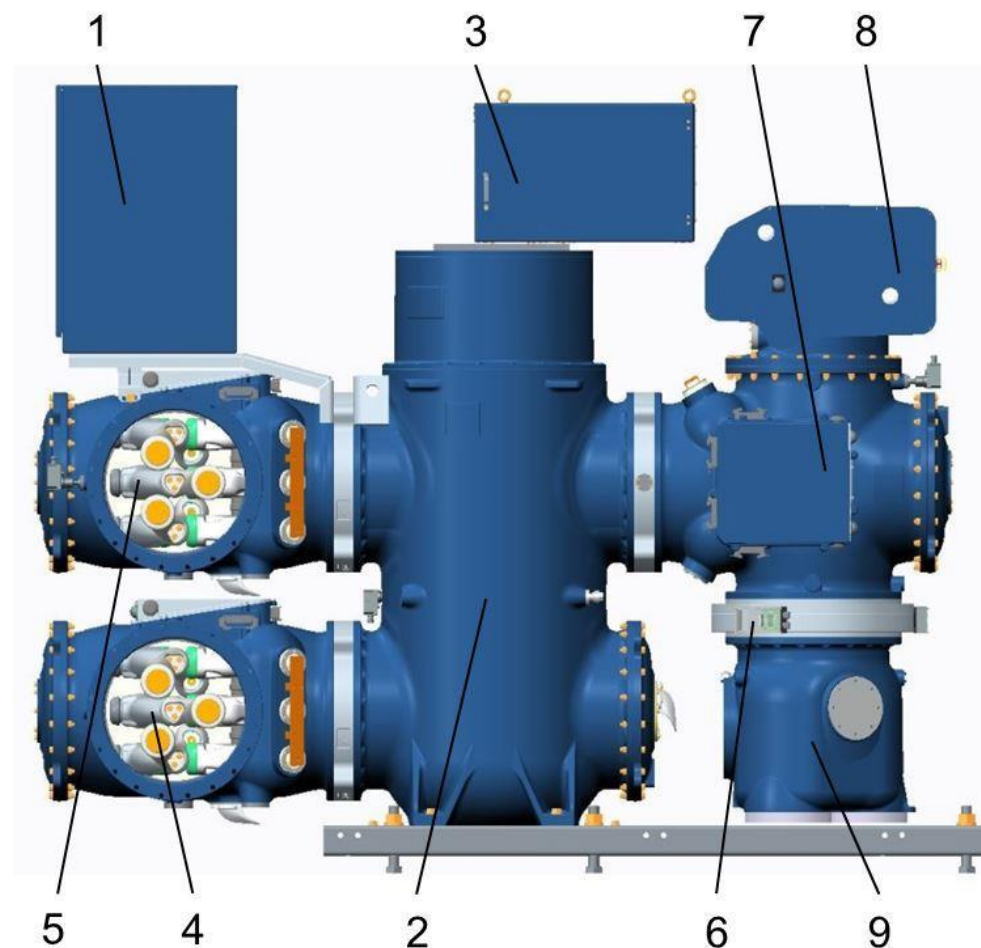

Gas-insulated switchgear 8VN1 Blue GIS™ up to 145 kV / 50 kA

Technical data (with conventional instrument transformer)

Switchgear type	8VN1	
Rated voltage	up to	145 kV
Rated frequency		50 / 60 Hz
Rated short-duration power-frequency withstand voltage (1 min)	up to	275 kV
Rated lightning impulse withstand voltage (1.2 / 50 μs)	up to	650 kV
Rated continuous current - busbar	up to	3150 A
Rated continuous current - feeder / bus coupler	up to	3150 A
Rated short-circuit breaking current	up to	50 kA
Rated peak withstand current	up to	135 kA
Rated short-time withstand current (up to 3 s)	up to	50 kA
Leakage rate per year and gas compartment (type-tested)		< 0.1 %
Driving mechanism of circuit-breaker		stored-energy spring
Rated operating sequence		O-0.3 s-CO-3 min-CO
		CO-15 s-CO
Interrupter technology		Vacuum
Insulation medium		Clean air
Weight of SF ₆ or other fluorinated greenhouse gases		0 kg
GWP Global Warming Potential		0
CO ₂ equivalent		0 kg
Rated filling pressure		0,8 MPa abs
Bay width common pole drive		1000 mm
Bay height, depth (depending on bay arrangement)		3200 mm x 5500 mm
Bay weight (depending on bay arrangement)		6 t
Ambient temperature range		-50 °C up to +55 °C
Installation		indoor / outdoor
First major inspection		> 25 years
Expected lifetime		> 50 years
Standards		IEC / IEEE
Other values on request		

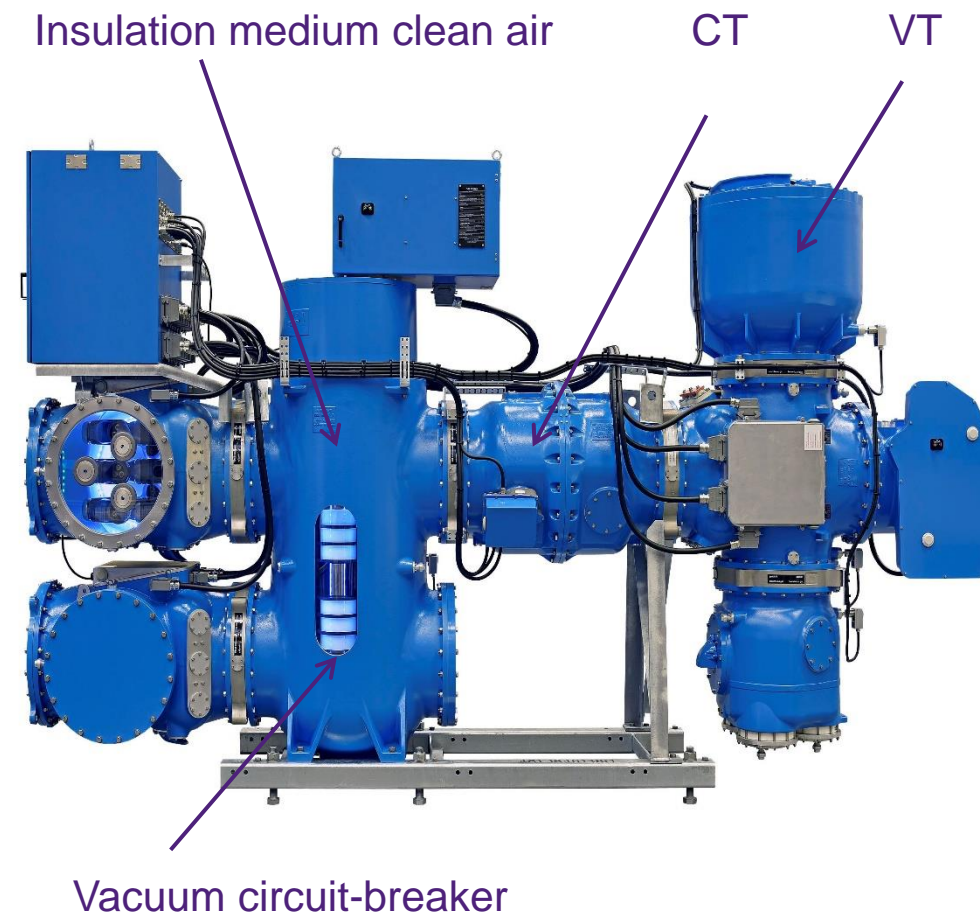

Gas-insulated switchgear 8VN1 Blue GIS™ up to 145 kV / 50 kA Switchgear bay (with conventional instrument transformer)

- 1 Integrated local control cubicle
- 2 Circuit-breaker with vacuum interrupter
- 3 Spring-stored-energy operating mechanism with circuit-breaker control unit (common drive)
- 4 Busbar I with disconnect and earthing switch
- 5 Busbar II with disconnect and earthing switch
- 6 Current transformer
- 7 Outgoing module with disconnect and earthing switch
- 8 Voltage transformer
- 9 Make-proof earthing switch (high speed)
- 10 Cable connection module

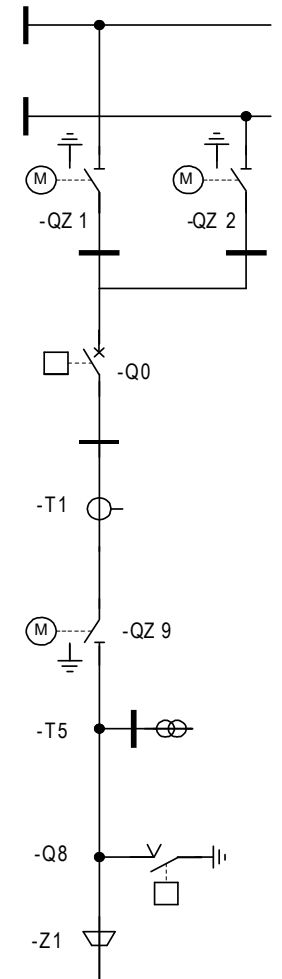
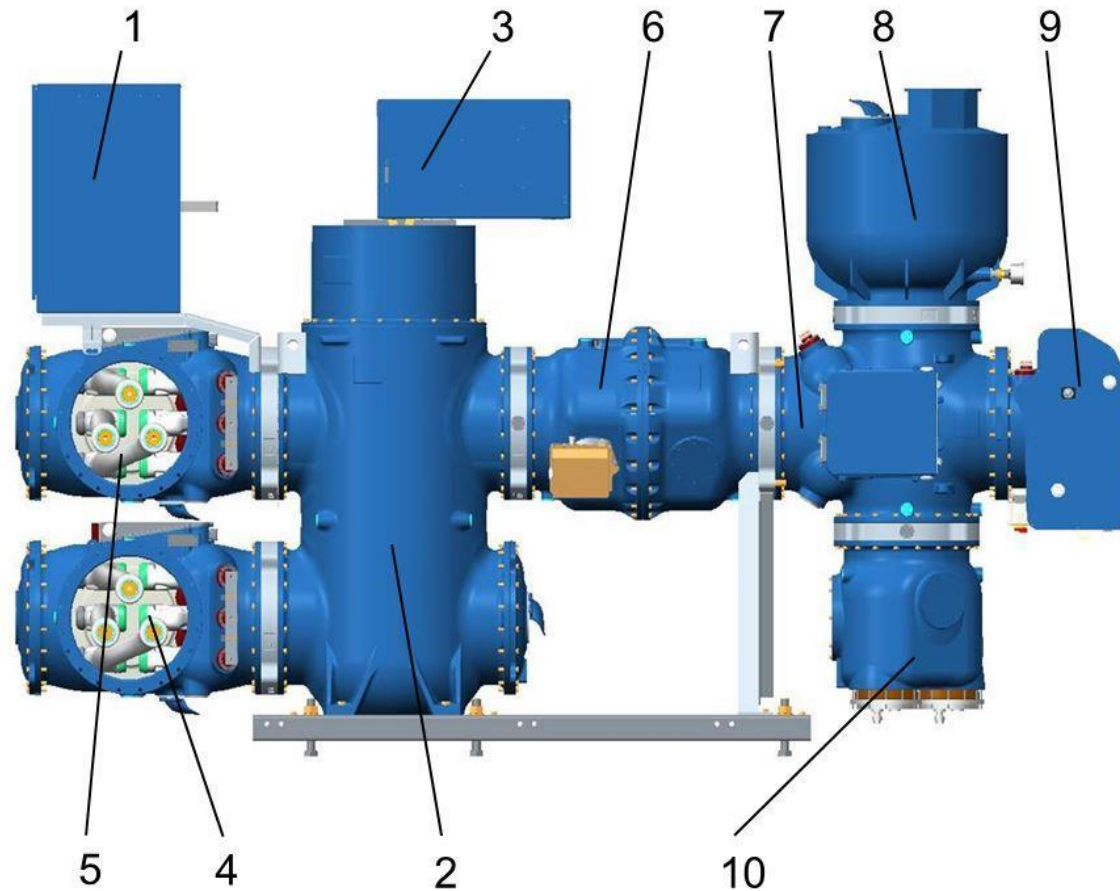

Gas-insulated switchgear 8VN1 Blue GIS™ up to 145 kV / 50 kA

Modular structure

Switchgear cable bay

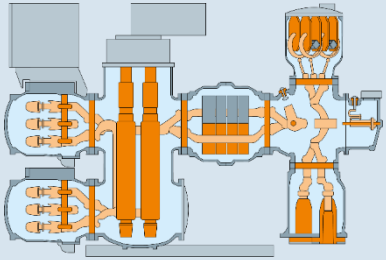

Vacuum circuit-breaker

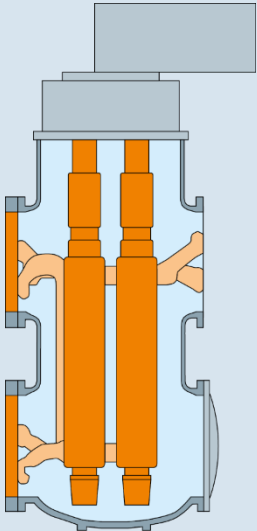

Disconnecter / earthing switch (cross module)

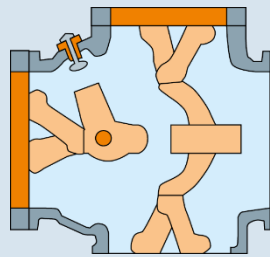

High-speed earthing switch

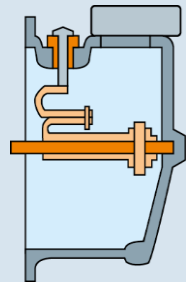

Current transformer

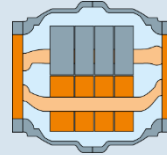

Voltage transformer

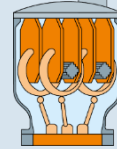

LPIT (Low Power Instrument Transformer)

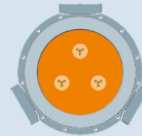

Surge arrester

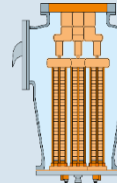

Cable module

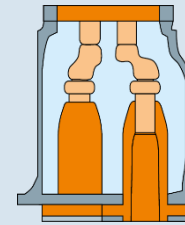

Outdoor bushing

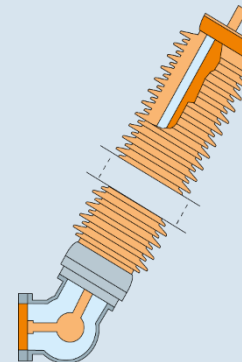

Extension modules

Three-phase

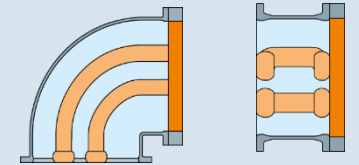

Splitting module 1/3-phase

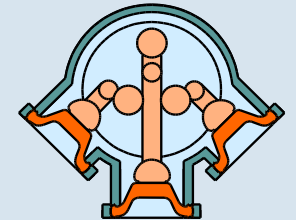

Gas-insulated switchgear 8VN1 Blue GIS™ up to 145 kV / 50 kA

Circuit-breaker module

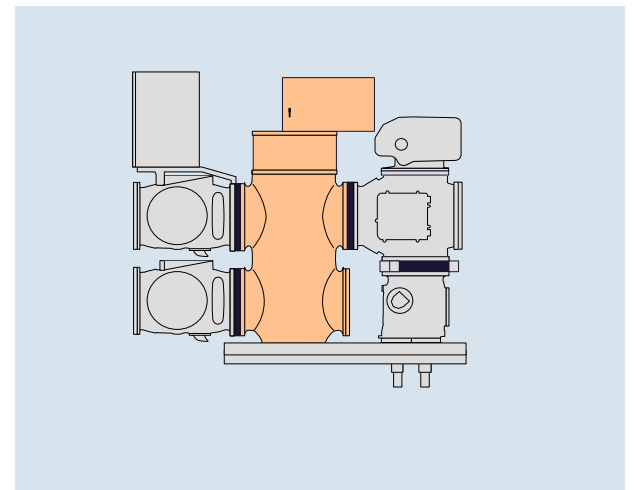
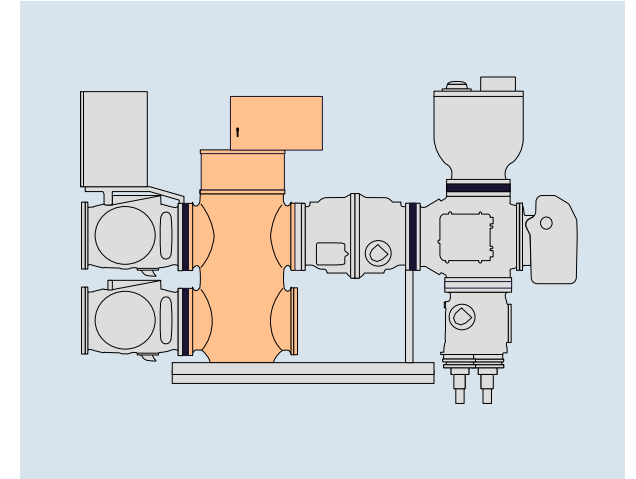
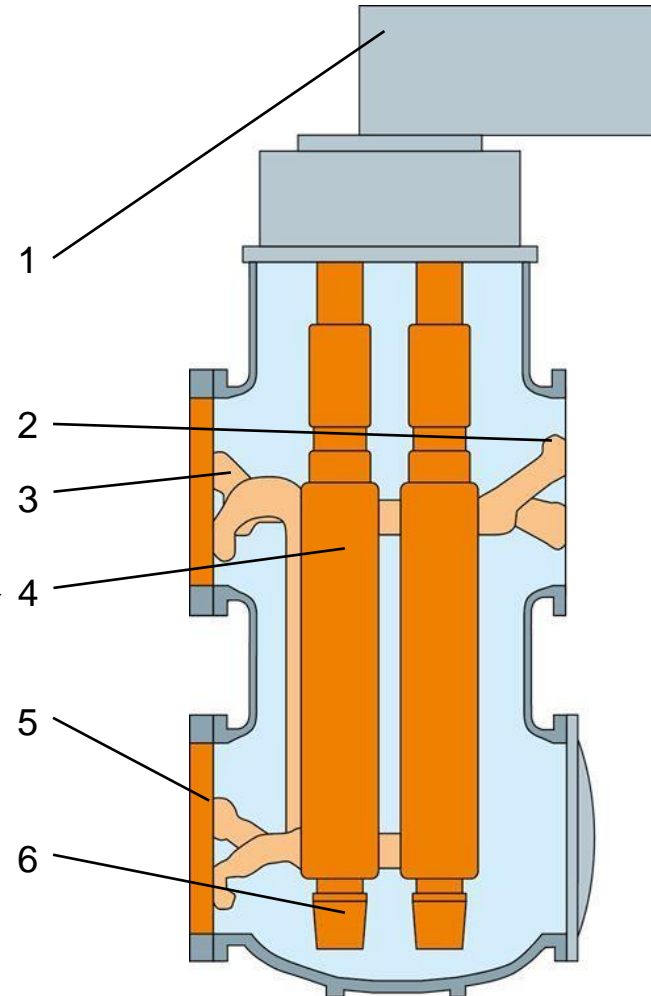

- 1 Spring-stored-energy operating mechanism with circuit-breaker control unit (single or common drive)
- 2 Connection to current transformer
- 3 Connection to busbar II
- 4 Vacuum interrupter unit
- 5 Connection to busbar I
- 6 Insulating support

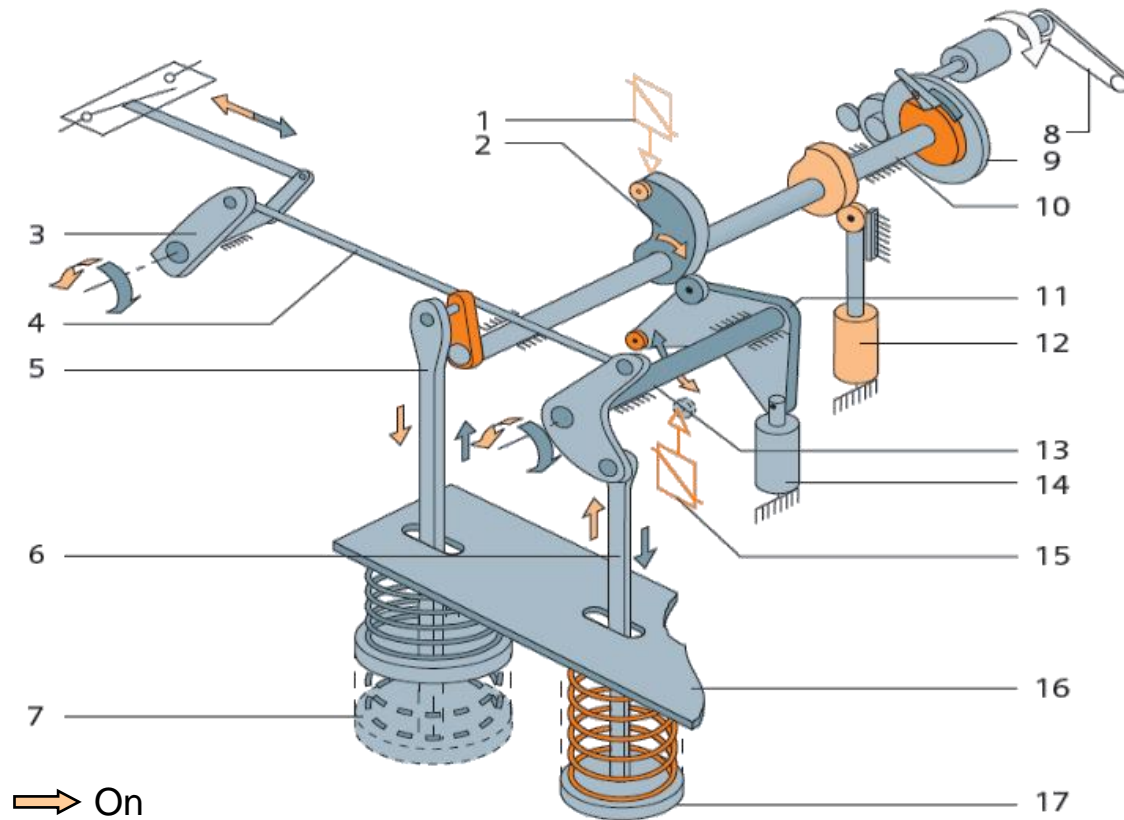

Gas-insulated switchgear 8VN1 Blue GIS™ up to 145 kV / 50 kA

Spring operated mechanism



 On
 Off

"off" position
 (Closing spring loaded)

- 1 Closing release
- 2 Cam plate
- 3 Coupling linkage
- 4 Operating rod
- 5 Closing spring connecting rod
- 6 Opening spring connecting rod
- 7 Closing spring
- 8 Hand-wound mechanism
- 9 Charging mechanism
- 10 Charging shaft
- 11 Roller lever
- 12 Closing damper
- 13 Operating shaft
- 14 Opening damper
- 15 Opening release
- 16 Mechanism housing
- 17 Opening spring

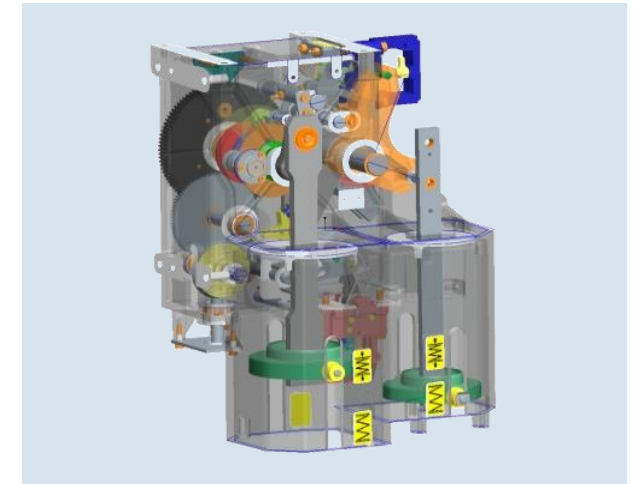

Gas-insulated switchgear 8VN1 Blue GIS™ up to 145 kV / 50 kA

Disconnecter module with earthing switch

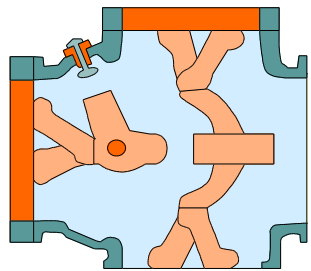

Busbar module

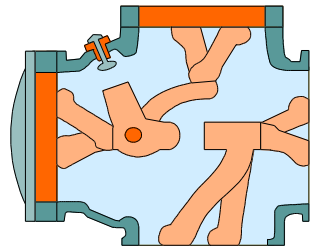

Sectionalizer

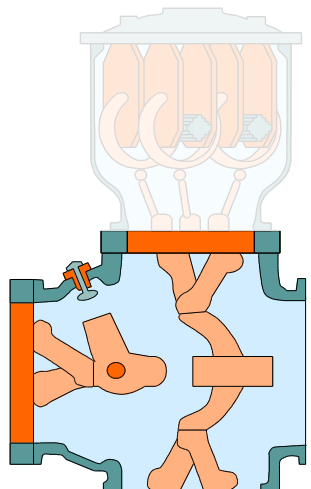

Outgoing module,
voltage transformer after
disconnecting switch

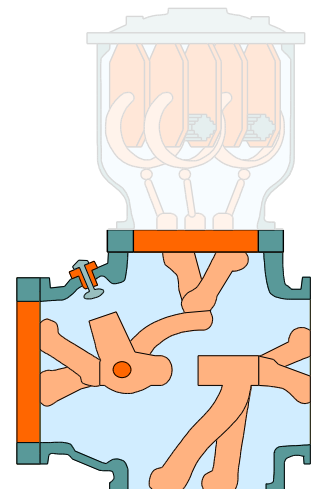

Outgoing module,
voltage transformer before
disconnecting switch

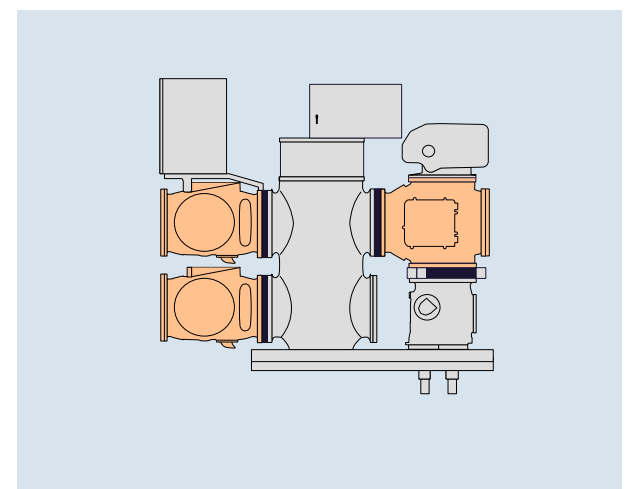
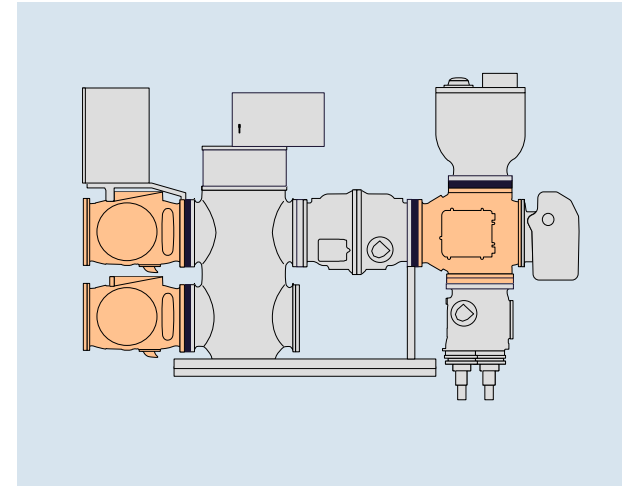

Gas-insulated switchgear 8VN1 Blue GIS™ up to 145 kV / 50 kA

Disconnecter module with earthing switch

Principle disconnecting switch:

Neutral position

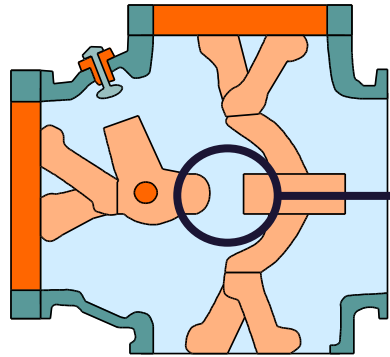

Disconnecting switch closed

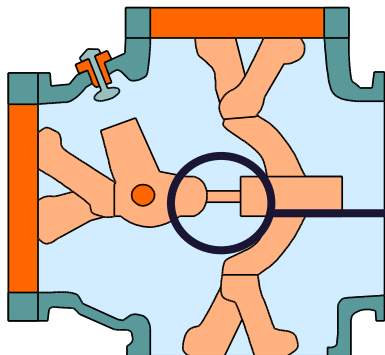

Gas-insulated switchgear 8VN1 Blue GIS™ up to 145 kV / 50 kA

Disconnecter module with earthing switch

Principle earthing switch:

Neutral position

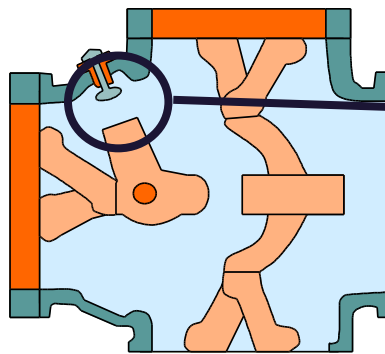

Earthing switch closed

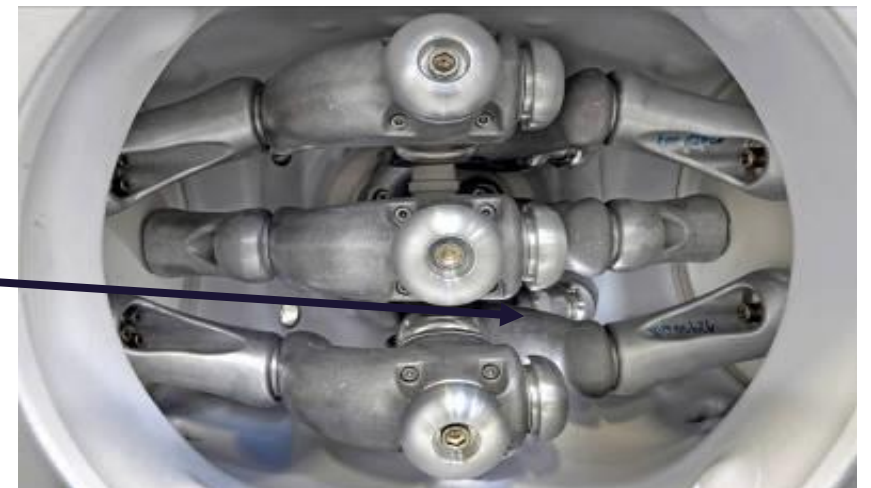
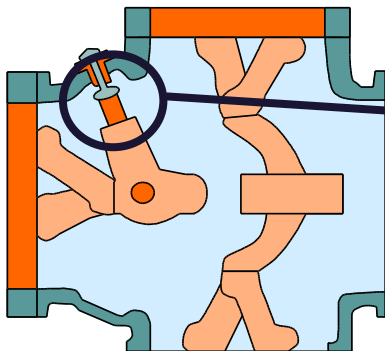

Gas-insulated switchgear 8VN1 Blue GIS™ up to 145 kV / 50 kA

High-speed earthing switch

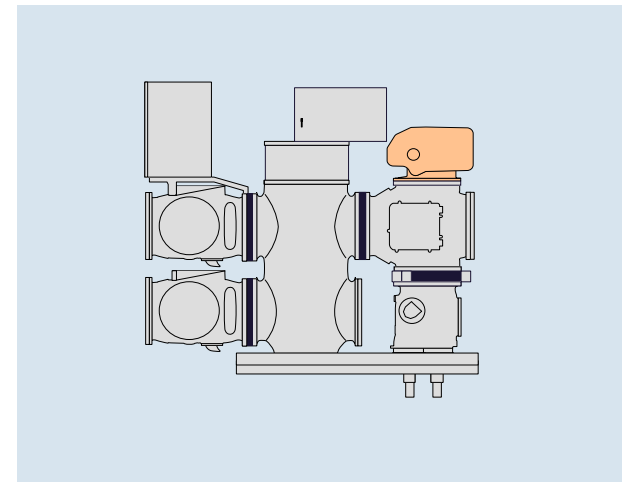
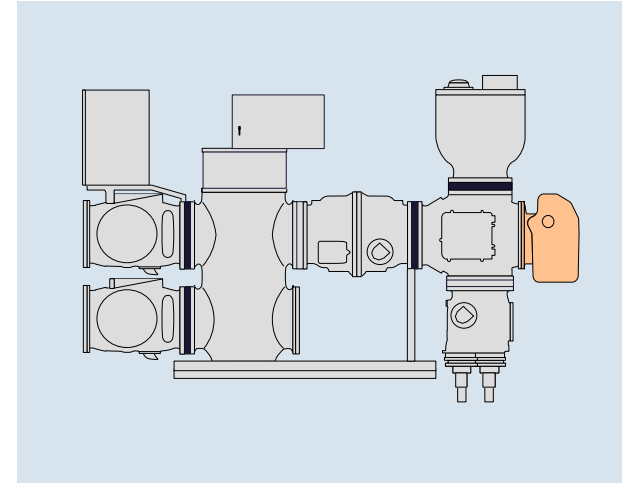
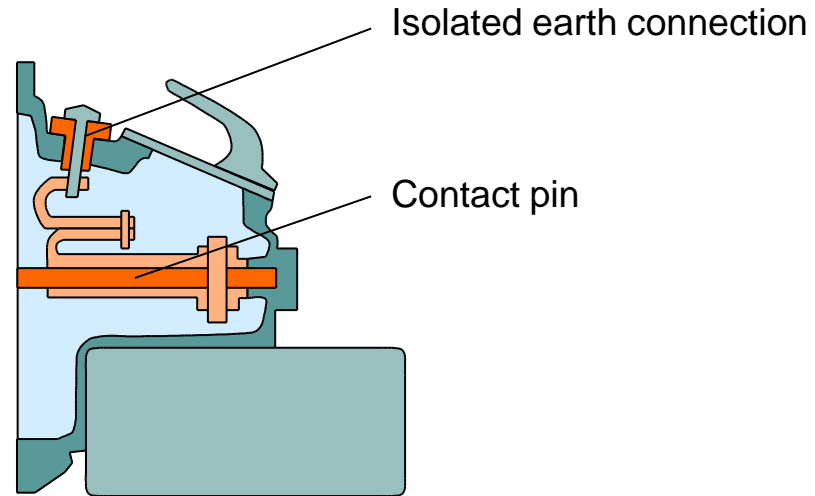

Gas-insulated switchgear 8VN1 Blue GIS™ up to 145 kV / 50 kA

Conventional vs. Low Power Instrument Transformer-Technology

Conventional Instrument Transformer

Inductive voltage transformer (VT)



+

Current transformer (CT)

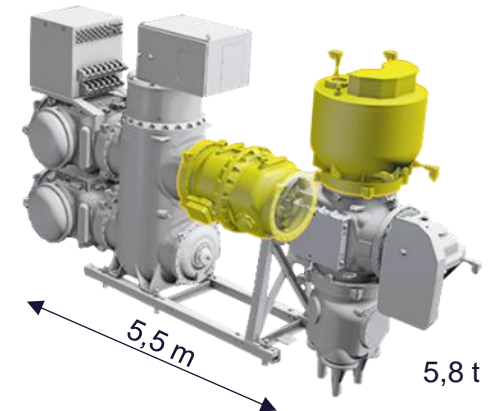

Low Power Instrument Transformer (LPIT)



+



=

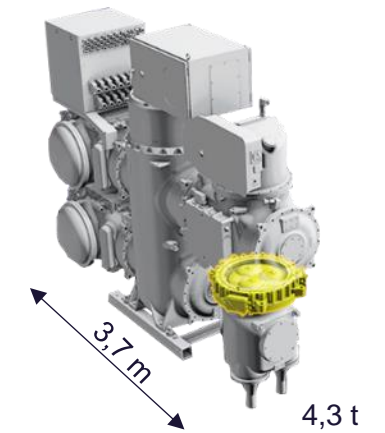

1 x capacitive voltage divider

2 x Rogowski coil

Cast resin partition with integrated voltage and current sensors

Gas-insulated switchgear 8VN1 Blue GIS™ up to 145 kV / 50 kA

8VN1 GIS equipped with LPITs

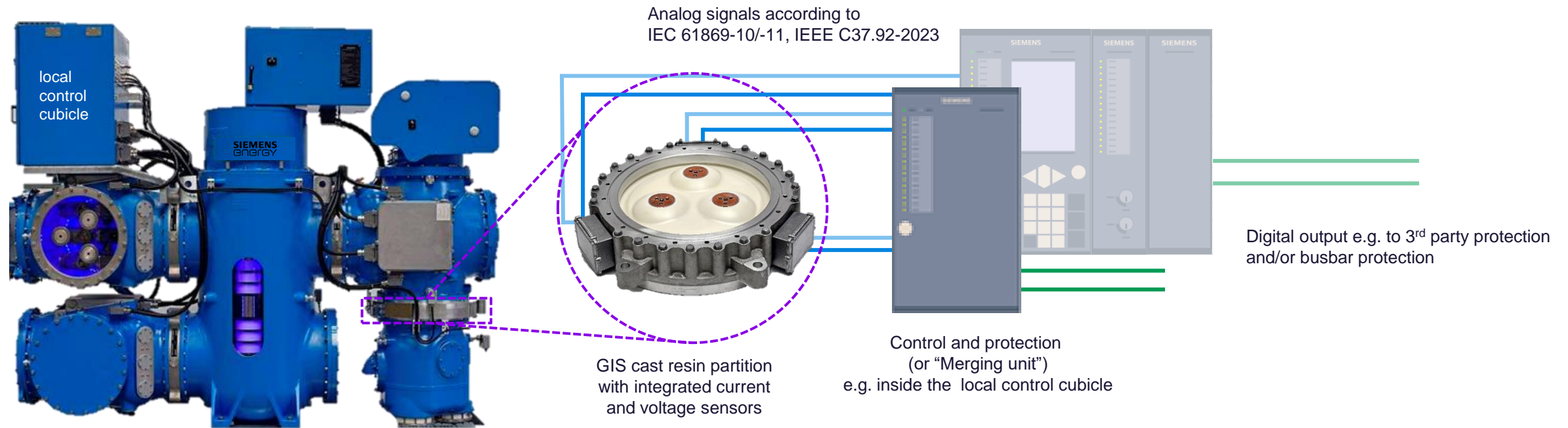

1. **Combined** passive voltage and current transformer according to IEC 61869-10/-11
2. **Redundant**: two current sensors and one voltage sensor in each bay (connected to a redundant protection system)
3. **Multi-purpose**: one device for protection and measurement
4. **Off the shelf**: the same device is used for every possible rated current $\geq 200\text{A}$
5. **Flexible** installation everywhere in the GIS

Gas-insulated switchgear 8VN1 Blue GIS™ up to 145 kV / 50 kA

Low Power Instrument Transformer (LPIT) in GIS

Customer Benefits

- **Decreased size and weight**
reduced weight of CT and VT (from approx. **1.500 kg to 85 kg**),
lower dimensions of GIS bay and significantly less cabling
- **Simple network connections with improved safety**
significantly reduced cabling, more thin cables, easier cable works, smaller cable ducts
low signal levels for safe maintenance and operations
- **Reduced failure rate**
because connection failures are less likely to occur
- **Contribution to environmental protection**
no SF₆-gas in LPIT → lower CO₂ footprint (if used with SF₆ GIS)
- **Simplified engineering, approval (“rating plate”) and logistics**
only one hardware variant for current and voltage measurements
uniform configuration → no approval (at an early project status) needed
- **Improved measurement behavior**
with wide dynamic range due to no saturation effect in multi-purpose current sensor
no magnetic losses, and no ferro-resonance effects



Gas-insulated switchgear 8VN1 Blue GIS™ up to 145 kV / 50 kA

Current transformer

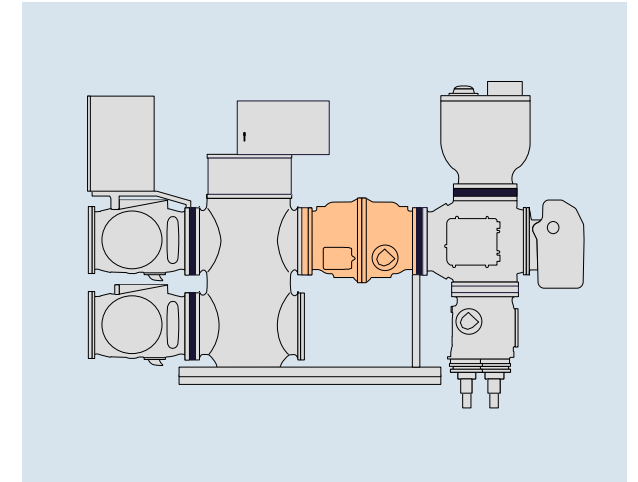
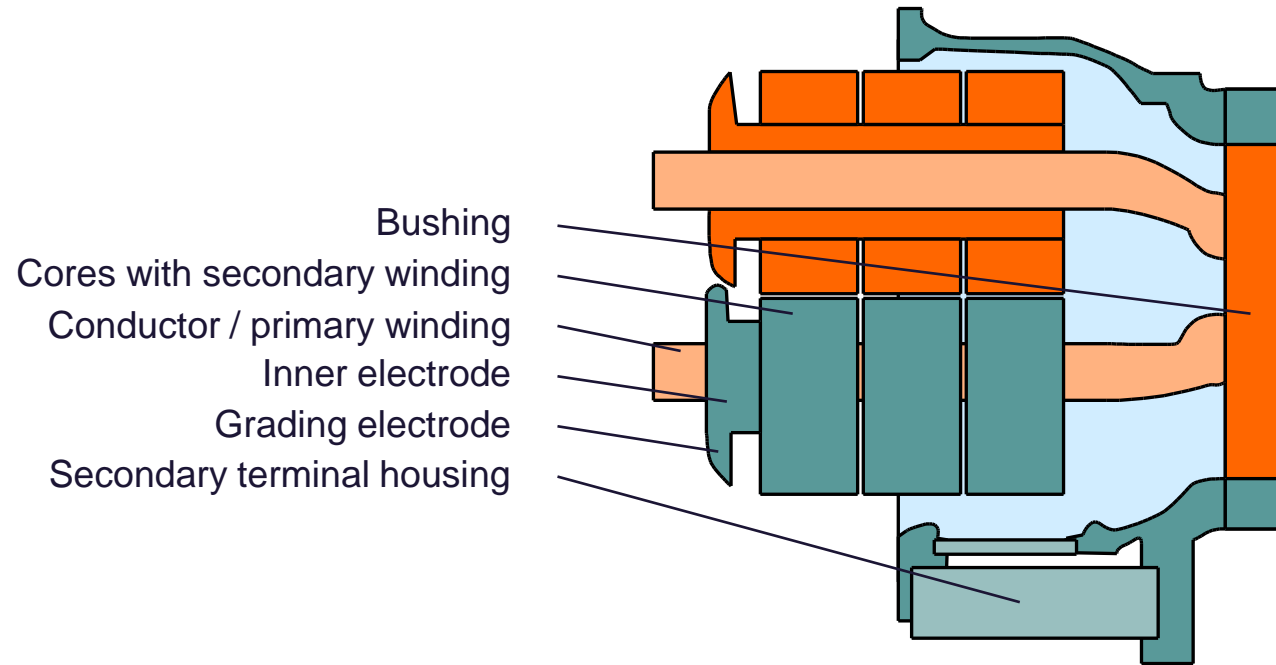

Gas-insulated switchgear 8VN1 Blue GIS™ up to 145 kV / 50 kA

Voltage transformer

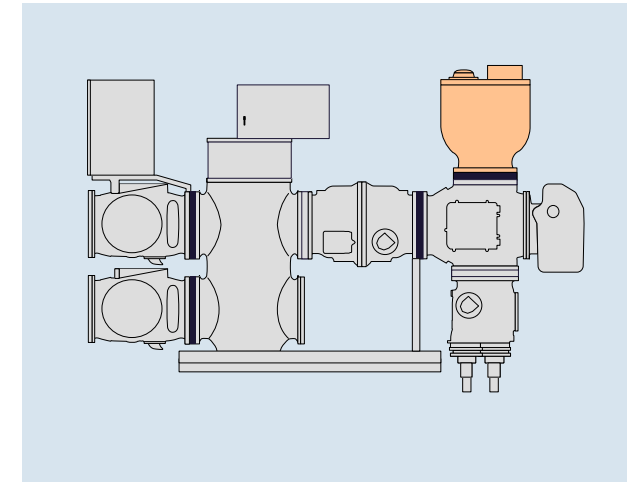
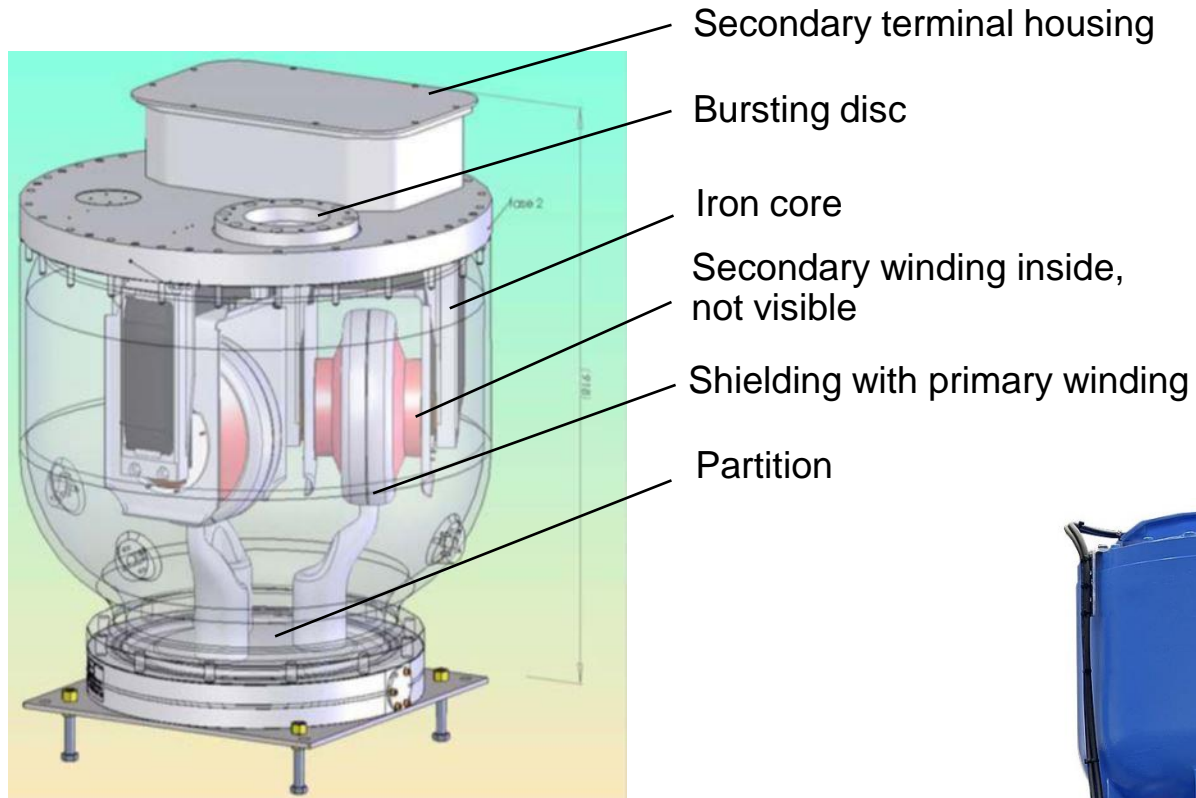

Gas-insulated switchgear 8VN1 Blue GIS™ up to 145 kV / 50 kA

Splitting module 1-/3-phase



Example: 8DN85 up to 145 kV

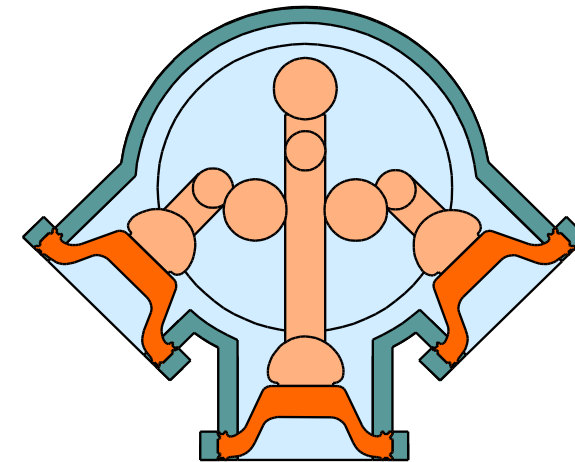
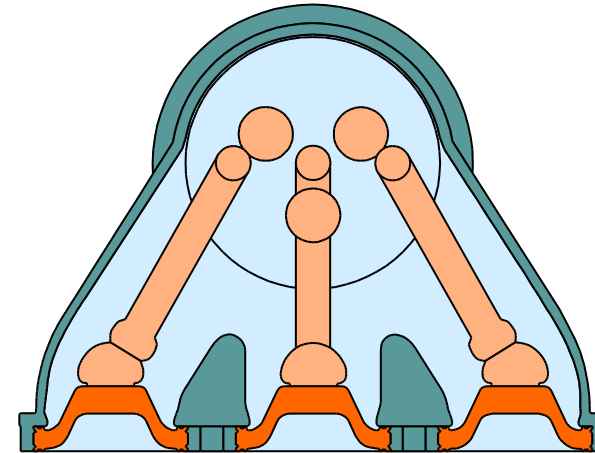

Gas-insulated switchgear 8VN1 Blue GIS™ up to 145 kV / 50 kA

Cable termination module plug-in

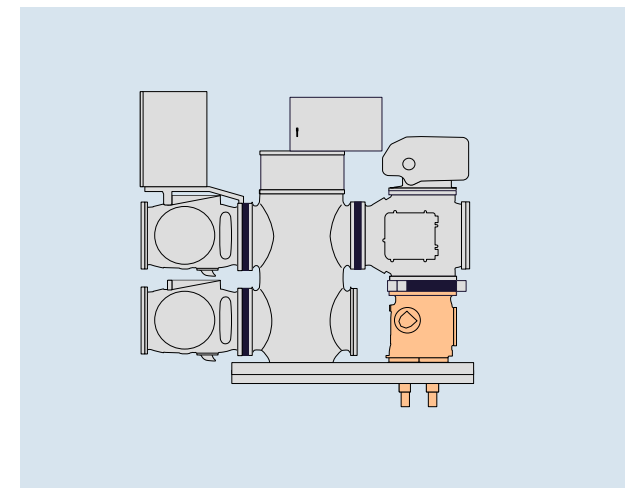
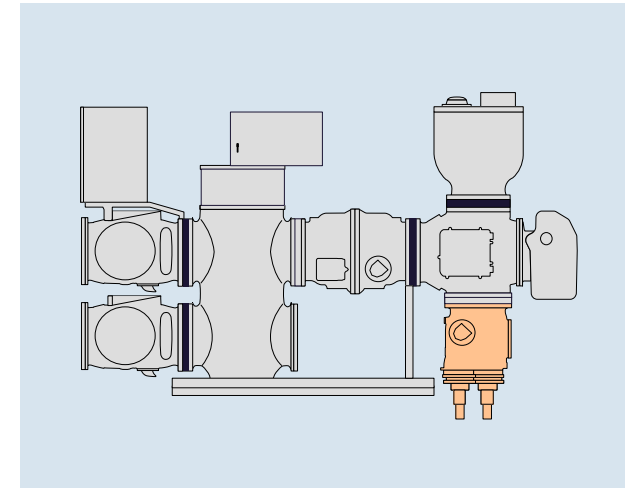
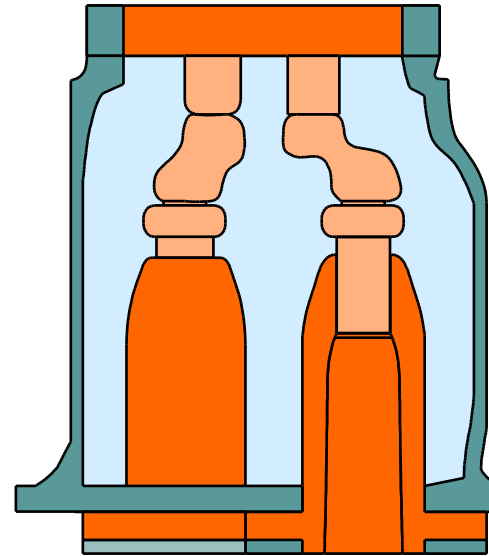
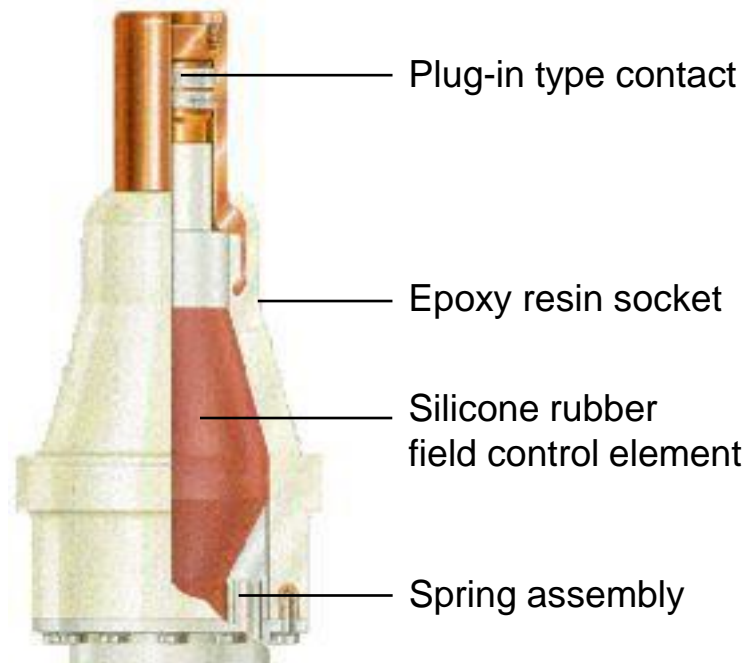

Gas-insulated switchgear 8VN1 Blue GIS™ up to 145 kV / 50 kA

Cable termination module plug-in-principle

- Inner-cone system, size acc. IEC standard
- metal-enclosed, all-insulated

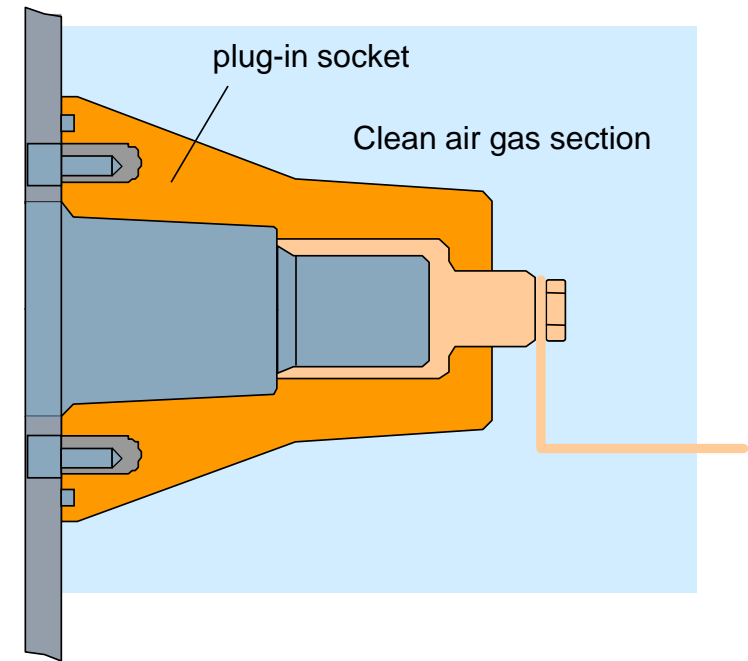
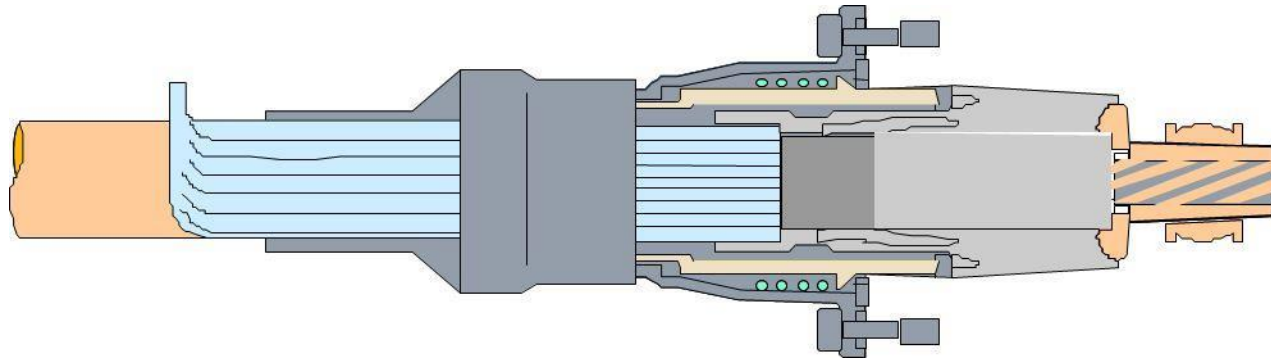

Gas-insulated switchgear 8VN1 Blue GIS™ up to 145 kV / 50 kA

Outdoor termination module

- Composite insulator

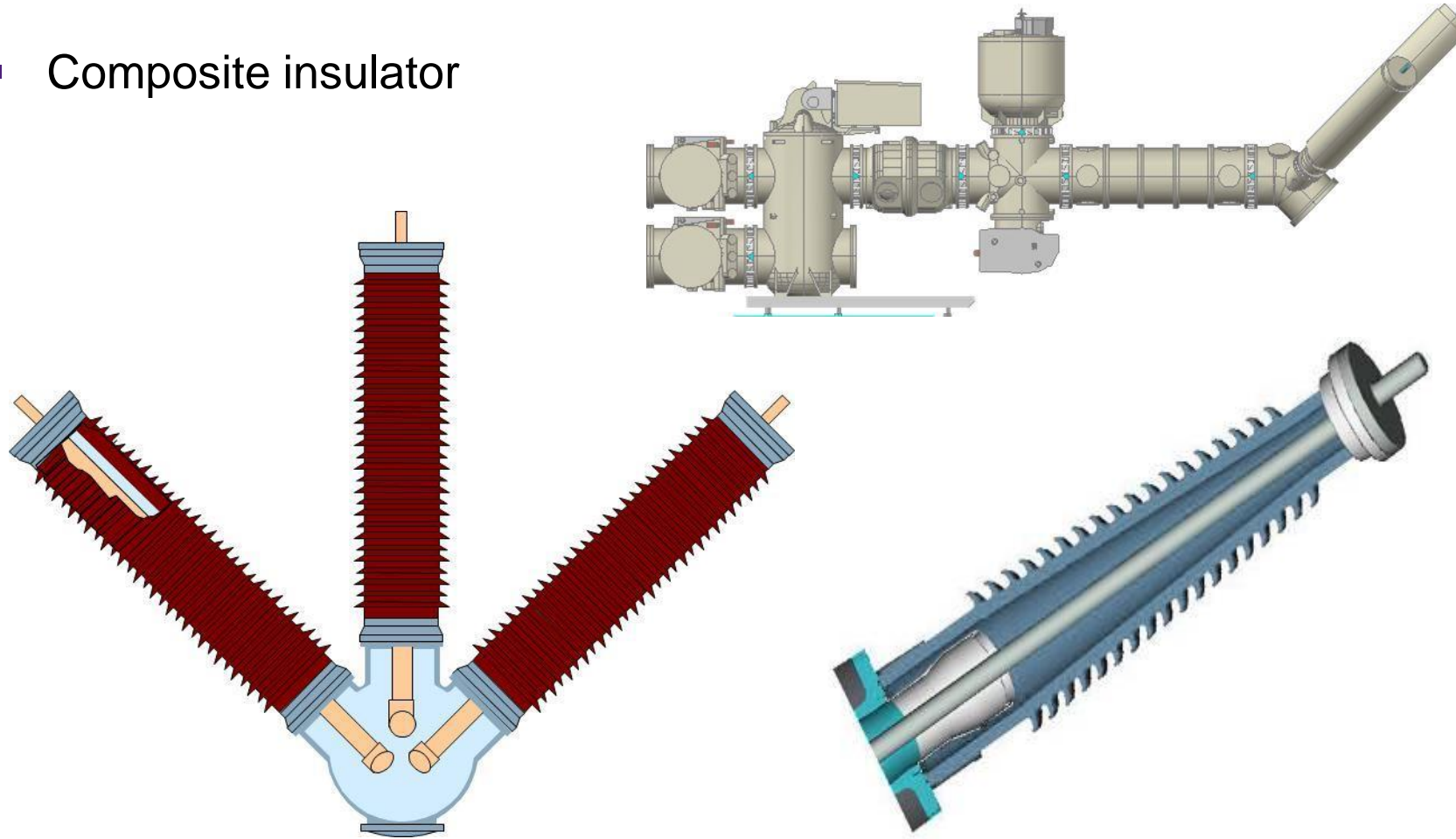

Example: clean air / bushing with composite insulator

Gas-insulated switchgear 8VN1 Blue GIS™ up to 145 kV / 50 kA

Surge arrester (3-phase)

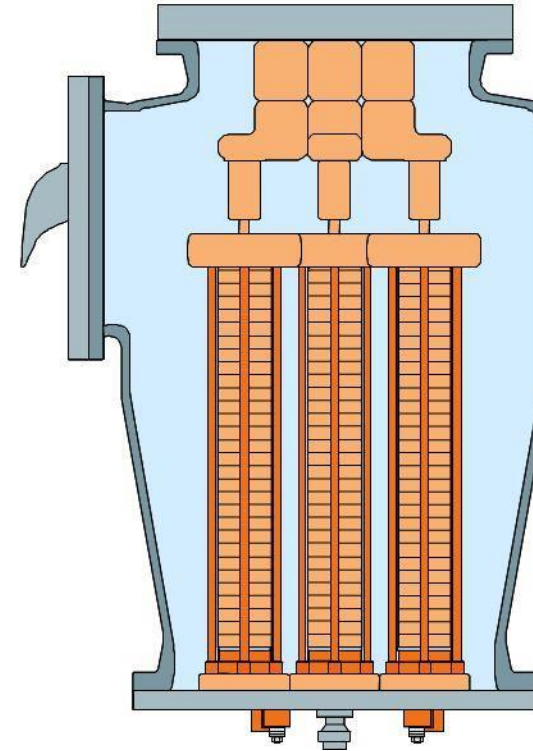
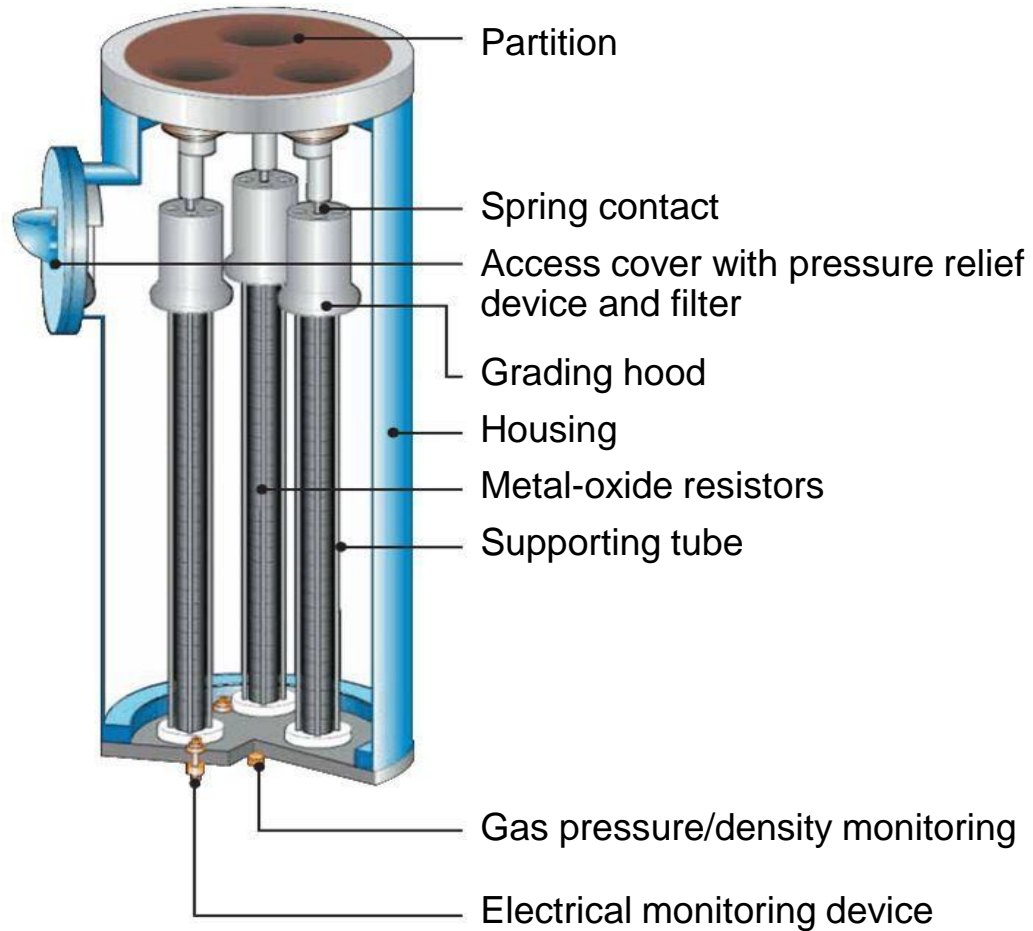

Gas-insulated switchgear 8VN1 Blue GIS™ up to 145 kV / 50 kA H-arrangement

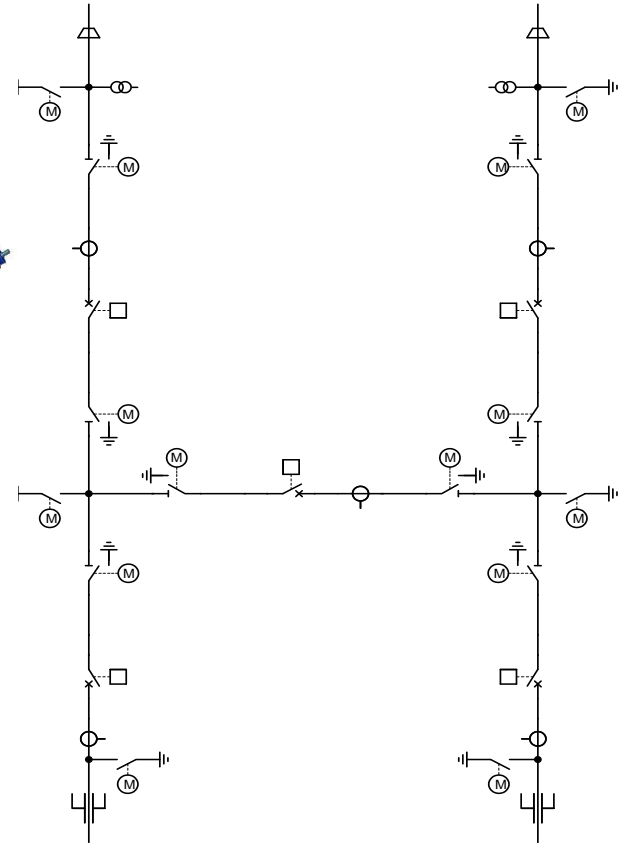
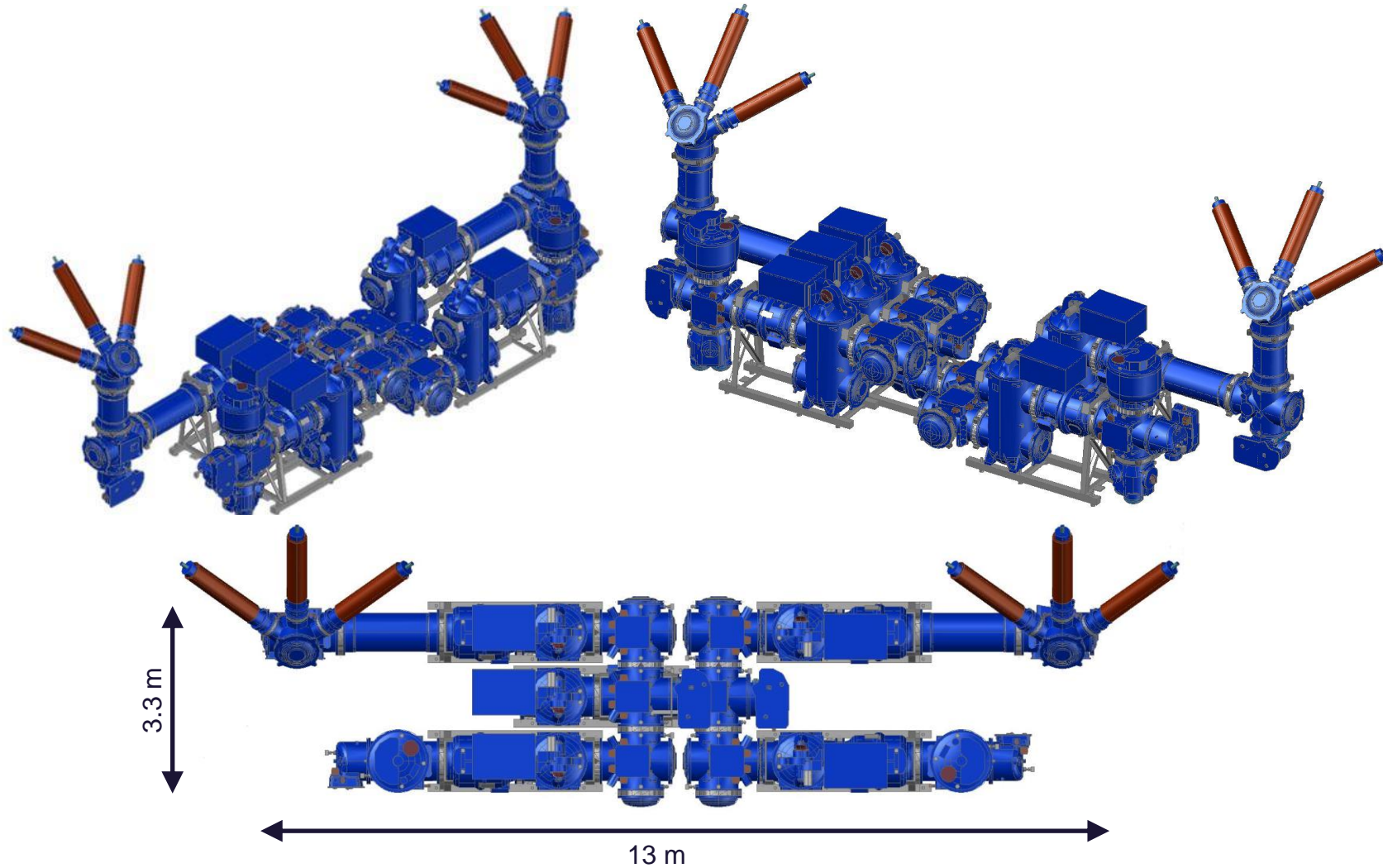

Gas-insulated switchgear 8VN1 Blue GIS™ up to 145 kV / 50 kA 1 ½ circuit-breaker arrangement

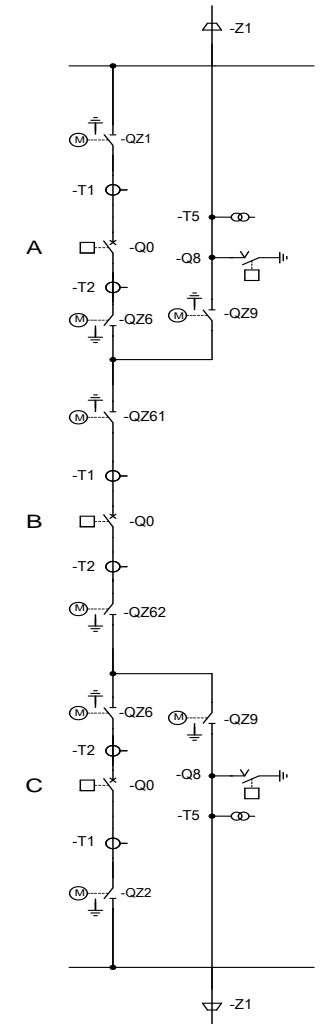
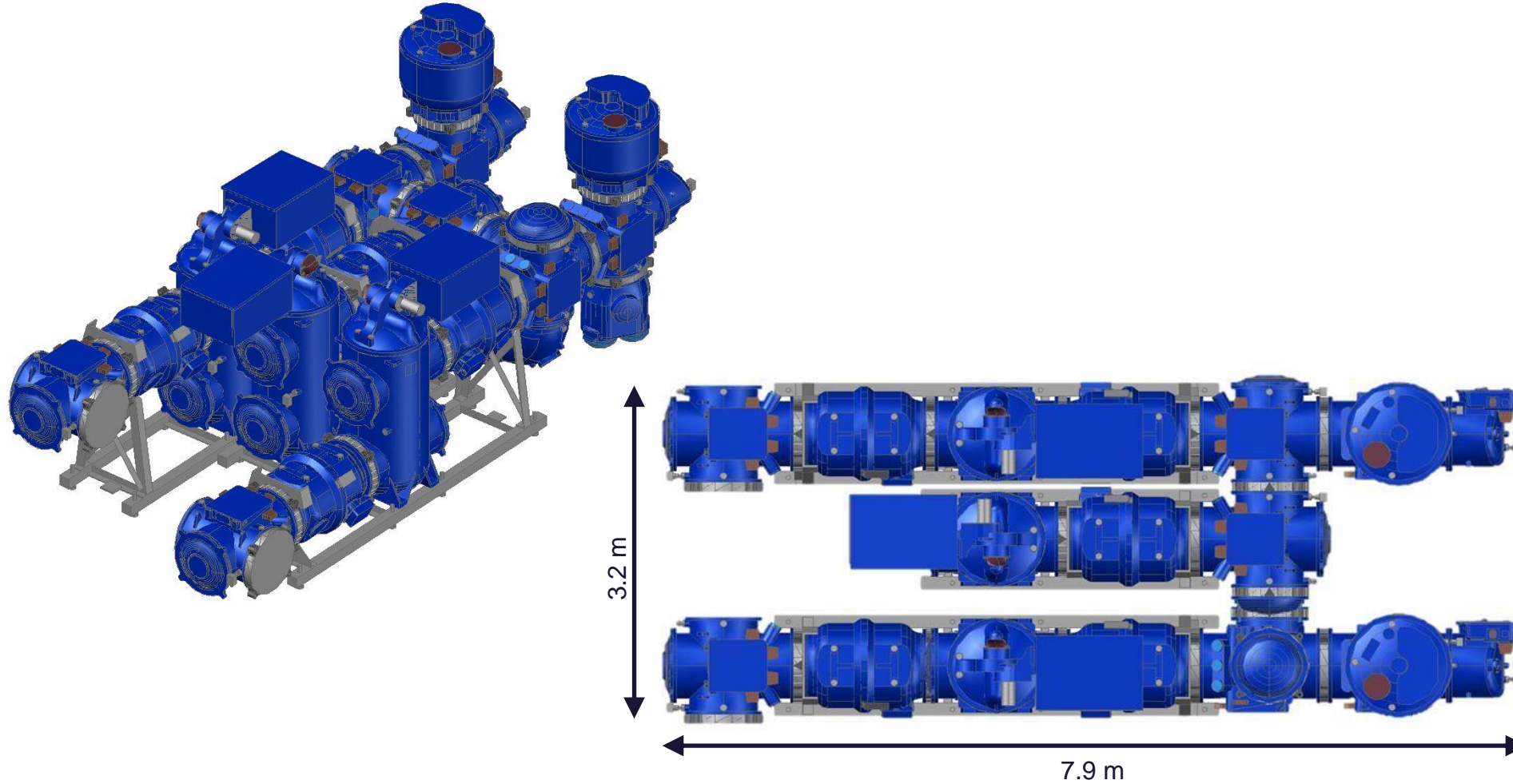

Gas-insulated switchgear 8VN1 Blue GIS™ up to 145 kV / 50 kA

Worldwide customer related improvements

Improved accessibility and ease of service

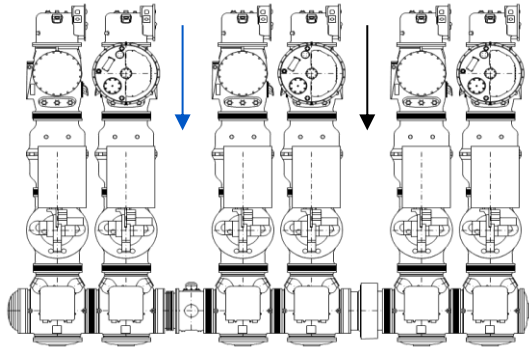

Environmental friendly, highest quality, reliability and robustness

- 100% reduced SF₆ volume
- GWP = 0
- gas tightness <0.1% p.a.
- seismic level 1.0 g standard
- 10,000 mechanical operations

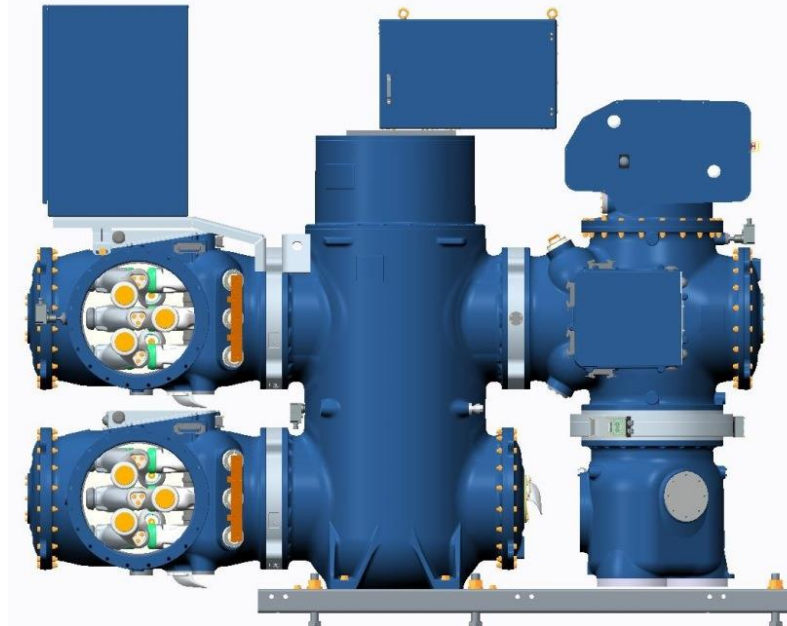

Compactness fits into small buildings



Big inspection windows (Ø46 mm)



Low Power Instrument Transformers (LPIT)



Dust tight and service friendly drives



Gas-insulated switchgear 8VN1 Blue GIS™ up to 145 kV / 50 kA

Accessibility

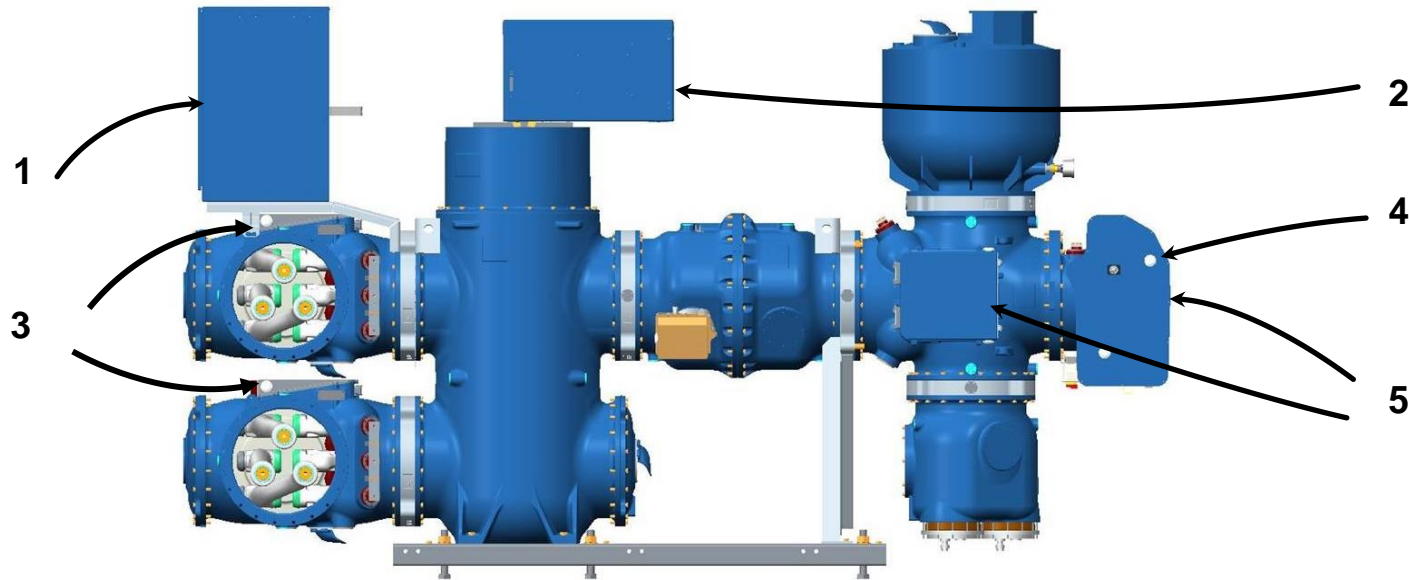

- 1 Integrated local control cubicle with process control unit (PLG)
- 2 CB control cubicle
- 3 Operating mechanism busbar, disconnecter and earthing switch - QZ1 + -QZ2
- 4 Operating mechanism earthing switch -Q8
- 5 Inspection windows for disconnecter and earthing switches

Access to motor drives, filling devices, density monitors, earthing bars, inspection windows etc.

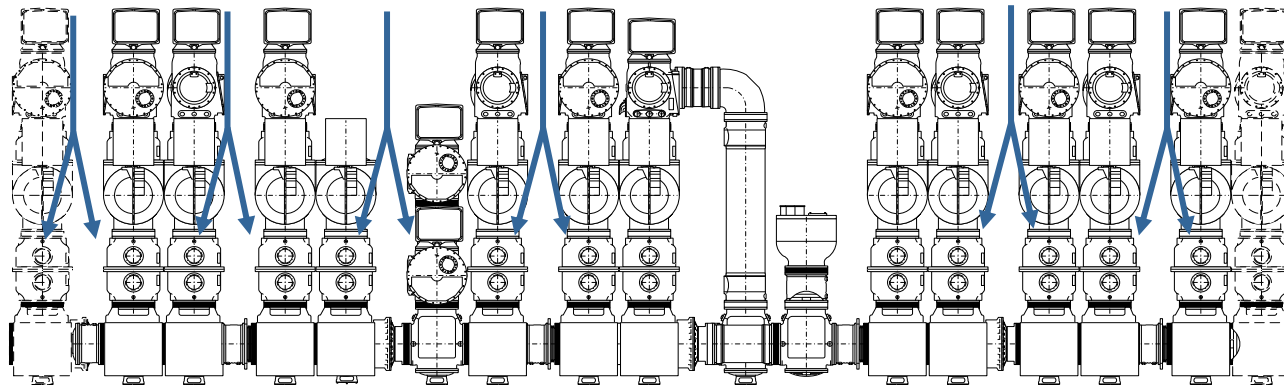





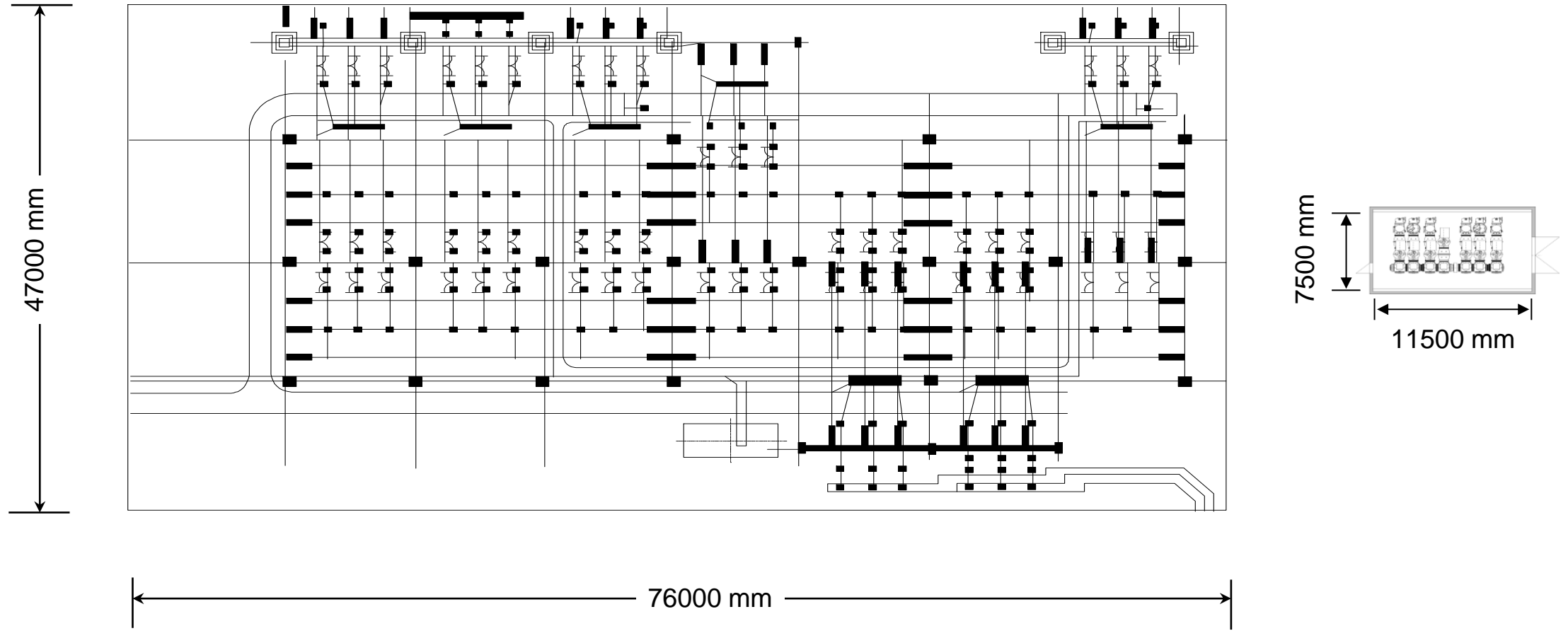

Gas-insulated switchgear 8VN1 Blue GIS™ up to 145 kV / 50 kA

Outdoor / gas-insulated switchgear



Gas-insulated switchgear 8VN1 Blue GIS™ up to 145 kV / 50 kA

Essentials at a glance

Environmental-friendly		The 8VN1 uses clean air as insulation medium. Clean air is a composition of 80% N ₂ and 20% O ₂ , cleaned and free from humidity (technical air). The clean air Global Warming Potential GWP is 0. Clean air is not and will not be part of the EU-F-gas regulation.
Experience		The 8VN1 is based on vacuum interrupter technology with more than 40 years successful operational experience in the field of medium-voltage and since 2010 in high-voltage.
Robustness		The fixed bay concept of the 8VN1 leads to an improved seismic resistance of 1.0 g (IEC 62271-207) without additional measures.
Indoor and outdoor application		The 8VN1 offers the well-known and proven modular design and can be used for indoor and outdoor applications from -50°C to +55°C at 50 / 60 Hz.
Highest quality and reliability		Compliance with the extended mechanical endurance class M2. 10,000 mechanical operations (CB, DS).
Adapter modules		8VN1 is compatible with all previously installed Siemens GIS of the same voltage level.

Leading grid operators install clean air technologies

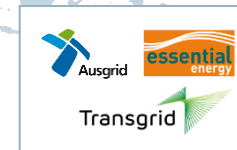

Globally around 6,000 Blue CB und GIS sold and 2,000+ units successfully in operation.
~7,600,000 tons of CO₂-equivalent saved

Status: December 2024

1 copyrights of company logos with the respective companies

2010 72.5 kV	
2017 145 kV	
2017 72.5 kV	
2019 145 kV	
2022 145 kV	
2023 420 kV	

Disclaimer

Subject to changes and errors. The information given in this document only contains general descriptions and/or performance features which may not always specifically reflect those described, or which may undergo modification in the course of further development of the products. The requested performance features are binding only when they are expressly agreed upon in the concluded contract.

All product designations, product names, etc. may contain trademarks or other rights of Siemens AG, its affiliated companies or third parties. Their unauthorized use may infringe the rights of the respective owner.

Contact page



Siemens Energy Global GmbH & Co. KG
Siemens Energy
Grid Technologies

E-mail:

support@siemens-energy.com

Further reading:

- [Siemens Energy Blue Products](#)
- [Siemens Energy Gas-insulated substations](#)
- [Siemens Energy Transmission Products](#)

[siemens-energy.com](https://www.siemens-energy.com)

