

# Metal-oxide Surge Arresters in High-voltage Power Systems



## Foreword to the fourth edition

This handbook on surge arresters first appeared in 2001. It enjoyed considerable success and was translated into several languages. A number of developments have of course taken place since 2001 relating to the technology of surge arresters as well as standardization, necessitating a first major revision in 2011 (Edition 3).

With the release of Edition 3.0 of the arrester test standard IEC 60099-4 in June 2014, however, the dimensioning procedure of arresters has fundamentally changed. In particular, the system of line discharge classes used until then, which only very indirectly reflected the energy handling capability of an arrester, was abandoned and replaced by a classification system that clearly differentiates between thermal and impulse energy handling capability. This change was based on the realization that although standard arresters in the network can be selected very easily according to line discharge classes, this is not the case for all the "special applications" that are also possible with today's modern MO arresters. These applications require a much more detailed consideration of the energy handling capability. The current arrester standard is still often referred to as the "new" arrester standard, so it is now time to reflect the changes therein in this arrester handbook.

This present fourth edition of the arrester handbook is once again a handbook on the fundamentals of metal-oxide surge arresters in high-voltage systems, reflecting the state-of-art in terms of technology and standards. It should enable a reader who is tackling this subject area for the first time to identify and to understand the main factors involved in dimensioning and selecting surge arresters, initially without the need to consult additional literature. To help with more difficult questions, a list of recent literature on selected surge arrester topics has been added.

The concept of the first edition has stood the test of time and has been kept unchanged. First, the handbook contains some basic information about the use of surge arresters and how they work. Next, there is a description of the constructive design features of what is by far the most frequently used type – surge arresters for outdoor applications in high-voltage and medium-voltage systems. There follows a section detailing the systematic procedure for the electrical and mechanical design of a surge arrester. Actual design examples are then described. Finally, there is a section on the current standards applicable to surge arresters and their use, and a reference section containing definitions of terms.

As the users of arresters are now confronted with finding arresters in the network according to the old line discharge class system as well as having to use arresters according to the new classification system, the description of the dimensioning of arresters according to the former line discharge class system was not completely discarded but moved to an appendix. This means that the dimensioning of arresters that are already present in the network remains easy to understand for the reader.

We would like to take this opportunity to expressly thank Prof. Volker Hinrichsen for preparing what is now the fourth edition of the arrester manual. Without him, this very helpful and descriptive book would have not been possible.

Any comments or suggestions about how to improve the handbook will be gratefully received.

## Table of contents

Foreword to the fourth edition	1
Table of contents	2
Tasks and operating principles of MO arresters	3
Constructive design of MO arresters	14
Configuring MO arresters	27
Choosing continuous operating voltage $U_c$ and rated voltage $U_r$	28
Selecting the nominal discharge current $I_n$	31
Selecting charge transfer rating $Q_{rs}$ , thermal energy rating $W_{th}$ and thermal charge rating $Q_{th}$	33
Selection and review of the protection levels	35
Selecting the housing	38
Service conditions	45
Examples	46
Example 1: "Solidly earthed neutral 72.5 kV system"	47
Example 2: "Resonant earthed neutral 123 kV system"	49
Example 3: "Solidly earthed neutral 245 kV system"	51
Example 4: "Solidly earthed neutral 420 kV system"	53
Example 5: "Solidly earthed neutral 550 kV system; standard case"	55
Example 6: "Solidly earthed neutral 500 kV system; special requirements"	57
Example 7: "Resonant earthed or isolated neutral 20 kV system"	59
Example 8: "Solidly earthed neutral 20 kV system"	61
Arresters to protect transformer neutral points	63
Standards	64
Further reading	67
Appendix 1: The former line discharge class system	71
Appendix 2: MO arresters in brief	75

## Tasks and operating principles of MO arresters

Surge arresters – or short, arresters – constitute an indispensable aid to [insulation coordination](#)<sup>1</sup> in electrical power supply systems. **Figure 1** makes this clear. There the voltages which may appear in a high-voltage electrical power system are given in per-unit of the peak value of the highest continuous phase-to-earth voltage<sup>2</sup>, depending on the duration of their appearance.

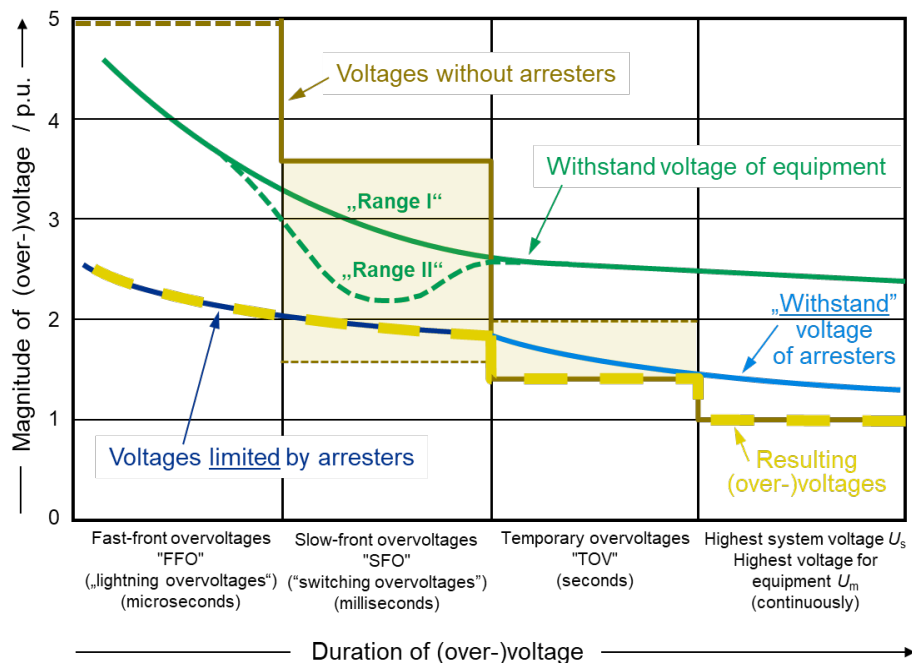

**Figure 1:** Schematic representation of the magnitude of voltages and overvoltages in a high-voltage electrical power system versus duration of their appearance ( $1 \text{ p.u.} = \sqrt{2} \cdot U_s / \sqrt{3}$ )

The time axis is roughly divided into the range of fast-front overvoltages (mainly [lightning overvoltages](#)) in the microsecond range, slow-front overvoltages (mainly [switching overvoltages](#)) in the millisecond range<sup>3</sup>, [temporary overvoltages](#) in the second range – which are commonly cited by the abbreviation "TOV" – and finally the temporally unlimited highest continuous system operation voltage. The voltage or overvoltage, which can be reached without the use of arresters, is a value of several p.u., depending on the system configuration. In Figure 1 respective values are given as typical ranges (in bright brown), and the curve in dark brown is representative for a solidly earthed sub-transmission system, for example, with maximum values of 1.4 p.u. for the temporary overvoltages and 3.6 p.u. for the switching overvoltages. If instead, one considers the green curve of the [withstand voltage](#) of equipment insulation – here equipment means electrical devices such as power transformers – one notices that starting in the range of switching overvoltages<sup>4</sup>, and especially for lightning overvoltages, which can be almost arbitrarily high, the equipment insulation cannot withstand the occurring

<sup>1</sup> Underlined terms are explained in greater detail in the appendix. In the electronic version of the handbook, clicking on the terms will automatically call up the definitions.

<sup>2</sup>  $1 \text{ p.u.} = \sqrt{2} \cdot U_s / \sqrt{3}$

<sup>3</sup> To make the text easier to read, "fast-front overvoltages" will be referred to as "lightning overvoltages", and "slow-front overvoltages" as "switching overvoltages", even though the terms are not fully equivalent according to standard IEC 60071-1 on insulation coordination.

<sup>4</sup> Switching overvoltages do not play an important role in the distribution and the sub-transmission systems, but gain importance with increasing voltage level in the high- and extra-high-voltage systems.

dielectric stresses<sup>1</sup>. At this point, the arresters intervene (dark blue curve in Figure 1). While in operation, it is certain that the voltage that occurs at the terminal of the device – while maintaining an adequate safety margin – will stay below the withstand voltage. Arresters' effect, therefore, involves lightning and switching overvoltages. However, arresters cannot and are not expected to limit temporary overvoltages. They must instead be designed to *withstand* the continuous system operation voltage without sustaining damage. This is shown in Figure 1 by the light blue part of the arrester curve on the right, in which the arrester – like any other device in the system – must demonstrate sufficient operational stability over and above likely voltage stress<sup>2</sup>.

The eventual resulting overvoltage stresses from the system are represented by the yellow dashed line in Figure 1. Without exception they are well below the withstand voltages, and thus proper insulation coordination is ensured.

Even though a great number of arresters which are [gapped arresters](#) with resistors made of [silicon-carbide](#) (SiC), are still in use, the arresters installed today are almost all [metal-oxide \(MO\) arresters](#) without gaps, which means arresters with resistors made of metal-oxide ([metal-oxide or MO resistors](#)). The distinctive feature of an MO resistor is its extremely non-linear [voltage-current or U-I-characteristic](#), rendering unnecessary the disconnection of the resistors from the line through serial spark-gaps, as is found in the arresters with SiC resistors. The currents passing through the arrester within the range of possibly applied power-frequency voltages are so small that the arrester almost behaves like an insulator. If, however, [surge currents](#) in the kiloampere range are injected into the arrester, such as is the case when lightning or switching overvoltages occur, then the resulting voltage across its terminals will remain low enough to protect the insulation of the associated device from the effects of overvoltage.

---

<sup>1</sup> The standard IEC 60071-1 on insulation coordination distinguishes equipment dielectrically according to whether electrical breakdowns take place exclusively according to the “streamer mechanism” or also according to the “leader mechanism”. The former are assigned to “[range I](#)” and the latter to “[range II](#)”. Due to the peculiarities of the leader discharge, the equipment in “range II” has a pronounced minimum of dielectric strength against switching overvoltages. Therefore, the green withstand voltage curve in Figure 1 is differentiated according to “range I” and “range II”.

<sup>2</sup> To clarify the two operating modes of an arrester: In the regime of temporary (power-frequency) overvoltages, it is an operation with a fixed voltage, i.e. the source (the network) has a significantly lower internal resistance than the load (the arrester), which still has a very high resistance at these voltages ( $R_{\text{source}} \ll R_{\text{load}}$ ). The network thus represents a load-independent voltage source, and a power-frequency current develops through the arrester depending on the applied voltage, the level of which is not influenced by this. In the upper, high-current regime of the U-I-characteristic, on the other hand, the arrester has a much lower resistance (internal resistance of just a few ohms) than the network ( $R_{\text{source}} \gg R_{\text{load}}$ ). This corresponds to operation on a load-independent current source. The transient current is thus fixed and not influenced by the arrester, but the level of the driving (over)voltage is changed by the arrester and limited to its residual voltage.

In **Figure 2**, an example is shown of the  $U$ - $I$ -characteristic of a typical MO arrester ([arrester class SM](#)) connected between phase and ground in a solidly earthed neutral 420 kV system<sup>12</sup>. On the ordinate the voltage peak value is depicted linearly, while on the abscissa current peak values are given in a logarithmic scale. In the depiction, the characteristic extends over a current range of 30  $\mu$ A to 40 kA,

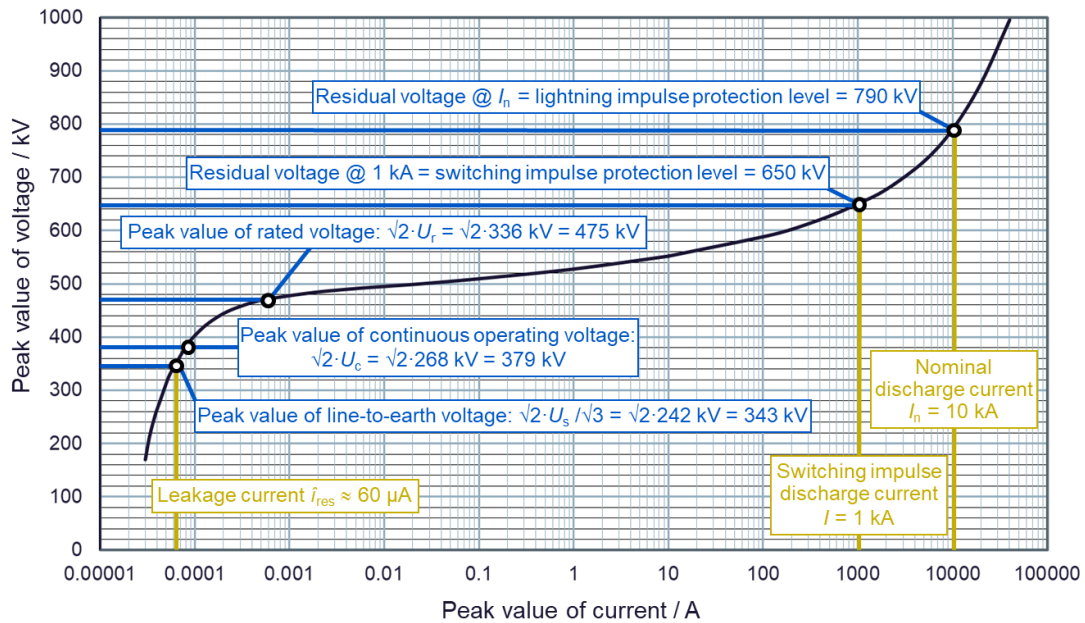

**Figure 2:**  $U$ - $I$ -characteristic of a typical MO arrester (class SM) in a solidly earthed neutral 420 kV system

that is, over nine decades of magnitude. Some important terms are explained below, moving from left to right on the characteristic.

The power-frequency voltage, while continuously applied to the arrester, is the highest phase-to-earth voltage of the system (1 p.u.). In this case the peak value is:

$$\hat{u} = \sqrt{2} \cdot U_s / \sqrt{3} = \sqrt{2} \cdot 420 \text{ kV} / \sqrt{3} = 343 \text{ kV}$$

At the same time, the so-called [leakage current](#) flows through the arrester. This consists of a large capacitive and a considerably smaller, resistive component. All in all, the leakage current is – as can also be seen in **Figure 3** – for the most part capacitive. In the  $U$ - $I$ -characteristic depiction, however, only the resistive component is represented. In this example it is  $\hat{i}_{\text{res}} \approx 60 \mu\text{A}$ , whereas the total current has a peak value of about 1.1 mA<sup>3</sup>.

The next significant characteristic point is the [continuous operating voltage](#) of the arrester. For this, the formal symbol  $U_c$  is used in accordance with the [IEC](#) standards; in Anglo-American circles the term

<sup>1</sup> It is extremely important when configuring arresters not to start with the [nominal system voltage  \$U\_n\$](#)  (in this case, 380 kV), but instead with the [highest voltage of the system  \$U\_s\$](#) .

<sup>2</sup> For further information, see also the keyword [voltage-current-characteristic](#) in Appendix 2.

<sup>3</sup> The current in Figure 3 is *almost* sinusoidal and *almost* purely capacitive. A closer look reveals that the current is less than 90 degrees out of phase with the voltage and deviates slightly from an ideal sine wave around the voltage peak due to the non-linear dependence of the resistive current on voltage. Below the voltage peak, it shows an instantaneous value of approximately 60  $\mu$ A, which corresponds to the resistive leakage current shown in the  $U$ - $I$ -characteristic Figure 2.

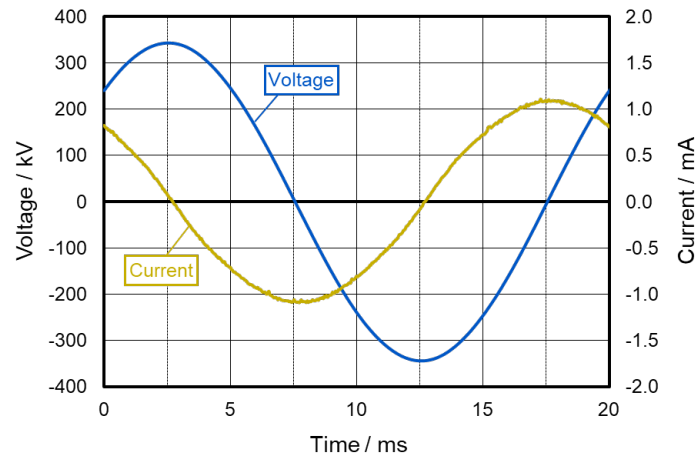

**Figure 3:** Applied voltage and leakage current of the sample arrester of Figure 2 when operated at phase-to-earth voltage ( $U_s = 420$  kV,  $U_r = 336$  kV)

**MCOV** (Maximum Continuous Operating Voltage) is customary. This is the power-frequency voltage, which the arrester can be operated at, without any kind of restrictions. All properties of the arrester, which have been demonstrated in the type tests, are valid, assuming that this arrester is energized at a voltage level equivalent to its continuous operating voltage. As is seen in Figure 2, the continuous operating voltage is greater than the highest continuously occurring phase-to-earth voltage. An allowance of at least 5% (IEC 60099-5) is recommended. With this, possible harmonics in the system voltage are taken into account. In the chosen example the arrester shows a continuous operating voltage of  $U_c = 268$  kV, which is almost 11% above the highest continuous possible phase-to-earth voltage<sup>1</sup>.

The name of the next characteristic point is somewhat misleading. The **rated voltage** (the symbol:  $U_r$ ) of a metal-oxide arrester is not, as one might at first assume, a voltage, which can be limitlessly applied (that one is the continuous operating voltage mentioned earlier). Instead it characterizes the capability of the arrester to deal with temporary overvoltages in the system. It can only be applied temporarily – the standards stipulate a time period of 10 seconds. Some manufacturers permit a time period of 100 seconds. The characteristic shows that under these conditions there is a leakage current (more precisely, its resistive component) of ca. 10 mA. In extended operation, this would lead to an increased operating temperature of the arrester, but not within a time period of ten or even one hundred seconds. The actual cause of the temporary time limit is the sudden great increase in the temperature and the frequent rise in leakage current due to its positive temperature coefficient (the temperature-dependence of the  $U$ - $I$ -characteristic is not shown in the simplified depiction in Figure 2), after, for example, the arrester has diverted a current impulse to the ground (that is, after it had to “operate”). In this case an extensive application of the rated voltage could render the arrester incapable of recooling; instead it would become **thermally unstable** and would continually heat up until it reached self-destruction (so-called **thermal runaway**).

<sup>1</sup> Choosing a higher continuous operating voltage than is minimally required has a beneficial effect on the stability of an arrester in continuous operation; see the section “Configuring MO Arresters”.

The rated and continuous operating voltage of an arrester are directly related to each other. The value of this ratio is almost always 1.25, with only a few exceptions, and is not manufacturer-dependent<sup>1</sup>. As a result in the chosen example, the rated voltage is  $U_r = 1.25 \cdot U_c \approx 336 \text{ kV}$ <sup>2</sup>.

This concludes the description of the part of the  $U$ - $I$ -characteristic curve relevant to power-frequency voltage. The curve then continues into an area in which even minimal voltage increases lead to a significant rise in the current. It is reserved for transient events within a time range of milli- and microseconds, in other words, for switching and lightning overvoltages. The sustained application of power-frequency voltage in this area of the characteristic would destroy the arrester in a fraction of a second.

The characteristic in the region of currents greater than about 100 A describes the protective characteristic of the arrester<sup>3</sup>. Its most important parameter is the [lightning impulse protection level](#) (LIPL, or  $U_{pl}$ ) depicted in Figure 2. This depicts the voltage, which drops across the arrester terminals when the [nominal discharge current](#) (symbol:  $I_n$ ) flows through the arrester. The aforementioned is a [lightning current impulse](#) of a standardized shape, whose amplitude is assigned to different standardized values from 2.5 kA to 20 kA, according to the IEC standard 60099-4. For high-voltage arresters (in systems with  $U_s \geq 72.5 \text{ kV}$ ) only values of 10 kA and 20 kA are common, and for medium-voltage arresters ( $U_s \leq 52 \text{ kV}$ ) the value of 5 kA is very important. The nominal discharge current divulges little about the properties of the arrester. Two “10 kA arresters” can have very different properties. When selecting an arrester the nominal discharge current therefore cannot be considered on its own. For the example in Figure 2, an arrester of [arrester class SM](#) was selected, which, according to the standard, has “by default” a nominal discharge current of 10 kA. Here the statement “lightning impulse protection level = 790 kV” means the following: a voltage at a maximum of 790 kV drops across the terminals when impressing a lightning current impulse of 8  $\mu\text{s}$  of [virtual front time](#), 20  $\mu\text{s}$  of [virtual time to half-value on the tail](#) and a peak value of 10 kA. These relationships are likewise depicted in **Figure 4**.

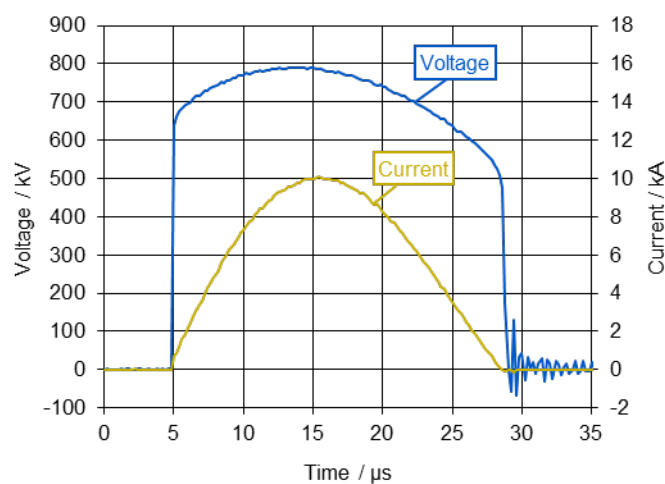

**Figure 4:** Residual voltage of the sample arrester of Figure 2 ( $U_r = 336 \text{ kV}$ ) at nominal discharge current ( $I_n = 10 \text{ kA}$ )

A lightning impulse protection level of 790 kV means that the peak value of the terminal voltage during a discharge, starting from normal operation at phase-to-earth voltage, increases by a factor of about

<sup>1</sup> Nevertheless there is no direct physical explanation for this relationship. It was found to be purely empirical (from results of [operating duty tests](#)).

<sup>2</sup> When rounding off in these calculations, deviations of up to 1 kV can occur. See the layout examples at the end of the handbook.

<sup>3</sup> The terms “protection” and “protective” are used interchangeably and unsystematically in both the IEC and the IEEE standards for arresters.

2.3 (790 kV compared to 343 kV), while at the same time the current amplitude increases by more than eight decades of magnitude (from 60  $\mu\text{A}$  to 10 kA). This substantiates the extreme non-linearity of the arrester's voltage-current-characteristic.

The description of the  $U$ - $I$ -characteristic ends with the [switching impulse protection level](#) (SIPL, or  $U_{ps}$ ). A [switching current impulse](#) (the "switching impulse discharge current") of 1 kA is used as standard for a class SM arrester. In the selected example, it shows a value of 650 kV. This means that the arrester typically limits switching overvoltages in the system to a value of less than 2 p.u. (1 p.u. = 343 kV).

Equipment in the 420-kV-system normally has a [standard rated lightning impulse withstand voltage](#)<sup>1</sup> (LIWV) of 1425 kV. This (test voltage) value, however, is not allowed to ever be attained in practice. In accordance with the application guide on insulation coordination, IEC 60071-2, the highest occurring voltage in the case of a non-self-restoring insulation in operation should stay below this value by a factor of 1.15, that is, not exceed 1239 kV. Nevertheless, the lightning impulse protection level of 790 kV of the sample arrester seems at first to offer more than enough protection. It should, however, be noted that this value represents a *voltage across the arrester terminals*, caused by the flow of an ideal standardized test current at the same level as the arrester's nominal discharge current. Three significant causes can allow the voltage at *the terminals of the equipment to be protected* to take on a considerably higher value:

- a) **Traveling wave processes:** Rapidly increasing overvoltages spread in the form of [traveling waves](#) on the line. In those places where the [surge impedance](#) of the line changes, refraction and reflection occur. Especially, a voltage wave will be totally positively reflected when reaching an unterminated end of the line. The voltage level at every instant and at every point on the line results from the sum of the different instantaneous values of each individual voltage wave. Thus, at the terminated end this value will be doubled. A connected transformer appears similar to an unterminated end since its winding inductivity for rapid functions exhibits a high impedance compared with the surge impedance of the line. The consequences of this are explained by means of a simplified example (**Figure 5**). An overvoltage surge with a front steepness of 1000 kV/ $\mu\text{s}$  runs towards a transformer. The propagation rate of such a surge on an overhead line, as in this example, is the speed of light, that is at 300 000 km/s or 300 m/ $\mu\text{s}$ . It is assumed that this arrester is an ideal one, which behaves like an insulator up to a voltage level of 800 kV, while higher overvoltages are limited to exactly 800 kV.

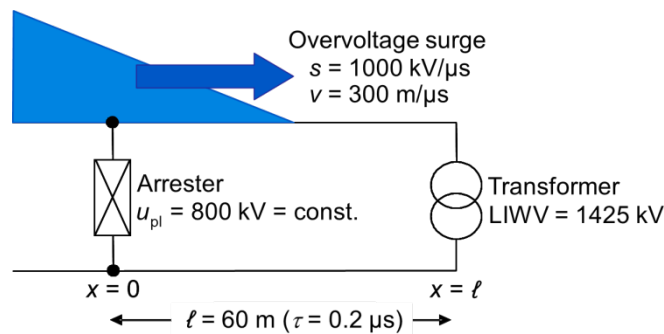

**Figure 5:** Simplified arrangement to illustrate the protective zone of an arrester (explanation see text)

<sup>1</sup> Frequently "BIL" – basic lightning impulse insulation level – is mentioned in this context. This term from the IEEE standards is, however, not defined in the IEC standards (see the comment on [BIL](#) in the appendix). According to the IEC, the correct term is "standard rated lightning impulse withstand voltage", which is abbreviated to LIWV.

The following explanation and **Figure 6** show how the voltages develop at the arrester and at the transformer.

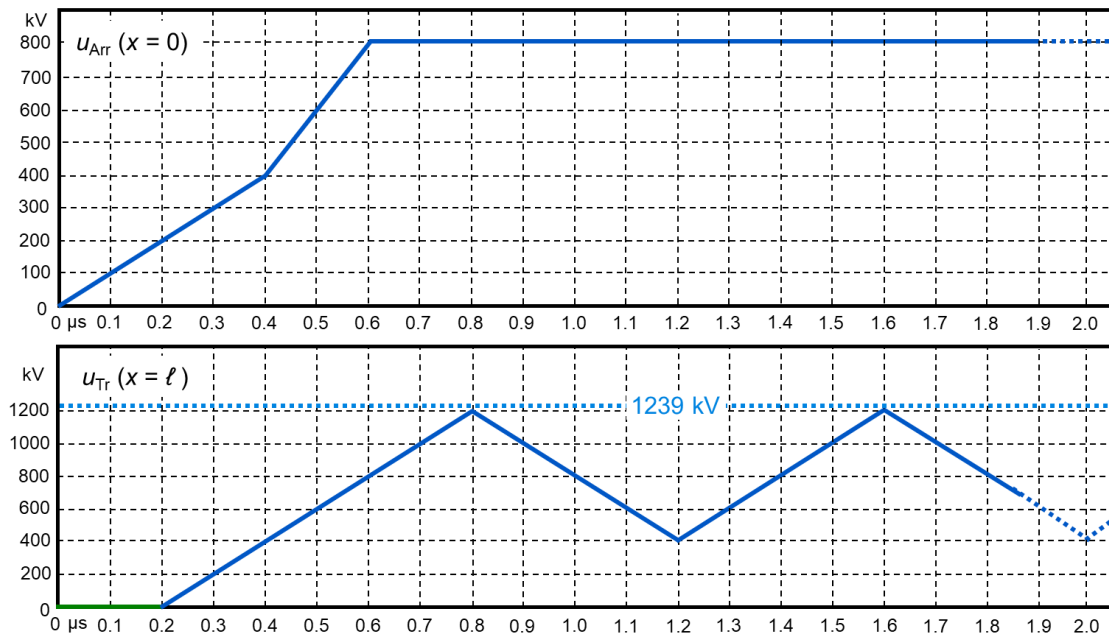

**Figure 6:** Development of voltages at the arrester (top) and at the transformer

The overvoltage surge first passes by the arrester and reaches the transformer  $0.2 \mu\text{s}$  later, which is the propagation time on the 60 m long stretch between the arrester and the transformer. At this time the voltage at the arrester has reached a value of  $1000 \text{ kV}/\mu\text{s} \cdot 0.2 \mu\text{s} = 200 \text{ kV}$ . Thus, the arrester is still behaving like an insulator. At the transformer the arriving surge is reflected. That is why an additional voltage surge, with the same shape and polarity, runs back from there. The superimposition of both surges causes the voltage at the transformer to increase at double the steepness, thus at  $2000 \text{ kV}/\mu\text{s}$ . Another  $0.2 \mu\text{s}$  means a voltage there of 400 kV. At the same time the reflected surge has reached the arrester, whose voltage up to this point in time has increased at the original rate of rise and, therefore, in the meantime, has also reached a voltage level of 400 kV. From now on the original and the reflected surges are superimposed on the arrester, and the voltage increases at a steepness of  $2000 \text{ kV}/\mu\text{s}$  not only at the transformer, but also here. The situation at the arrester does not change until the voltage at its terminals has reached the limiting value of 800 kV. In accordance with the starting assumption, a higher value cannot be taken on. According to the rules of traveling wave processes, this can only be reached if, from now on, a negative voltage surge with a steepness of  $2000 \text{ kV}/\mu\text{s}$  spreads out to both sides from the arrester. The superimposition of the original surge on that which was reflected from the transformer, and which is now again reflected from the arrester, causes the voltage at the arrester to maintain a constant value of 800 kV. Another  $0.2 \mu\text{s}$  passes – the propagation time needed for the 60 m stretch between the arrester and the transformer – before the negative surge reflected from the arrester reaches the transformer. During this time, however, the voltage there has already increased by another 400 kV. Therefore, it already has a value of 1200 kV. Only now the arrester makes itself “noticeable” at the transformer and limits the attained voltage. Since the arriving negative surge is reflected again in its full magnitude, not only does the voltage limit of 1200 kV result after the superimposition of all the partial surges at the transformer, but also a voltage reduction. If one carries out the calculation further in the manner described, the transformer takes on an oscillating voltage with a maximum value of 1200 kV and a cycle time of four times the traveling wave propagation time between the arrester and the transformer. In practice, the amplitude and shape of the oscillation are damped by various influences not considered here. But the example shows that the voltage at the equipment to

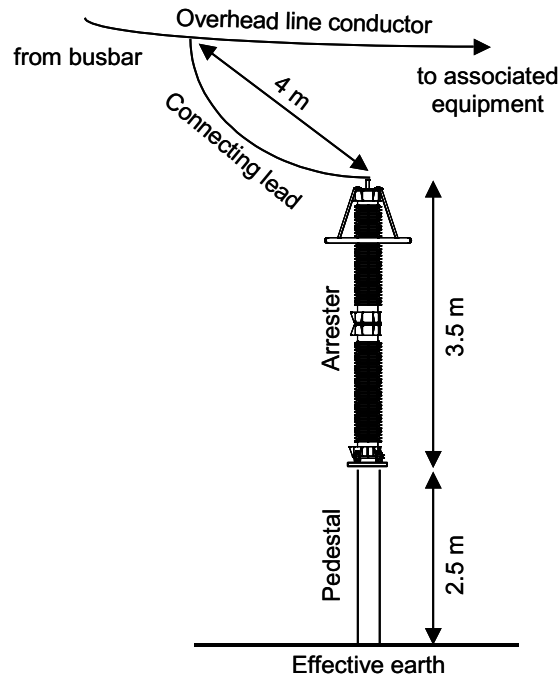

Figure 7: Typical arrangement of an arrester in a 420 kV substation

be protected can be considerably higher than that found at the arrester. Exactly how high depends mostly upon the distance between the arrester and the device to be protected, and on the front steepness of the voltage surge (the same example with a greater distance or a greater steepness would cause the given maximum permissible voltage of 1239 kV to already be exceeded at the transformer)<sup>1</sup>. This example makes it clear that the arrester has only a limited local [protective zone](#), which actually has the value of around 60 m as in this example.

- b) **Inductive voltage drops:** The current path shown in **Figure 7** of the discharge current from the termination of the arrester to the overhead line conductor, down to the effective earth, is ten meters long. At a specific value of 1  $\mu\text{H}$  per meter (guide value for the typical inductance of a stretched conductor at a great distance from other live or earthed parts) its inductivity is 10  $\mu\text{H}$ . A steepness of 10  $\text{kA}/\mu\text{s}$  of a lightning current impulse can typically be expected. Under these conditions the inductive voltage drop of the shown arrangement is

$$u = L \cdot \frac{di}{dt} = 10 \mu\text{H} \cdot 10 \text{kA}/\mu\text{s} = 100 \text{kV}$$

This does not necessarily appear exactly simultaneously at the peak value of the arrester residual voltage. However, this value of 100 kV demonstrates the order of magnitude of possible inductive voltage drops which can superimpose the arrester residual voltage.

- c) **Discharge currents higher than the arrester nominal discharge current:** the protection level of the arrester is defined as its residual voltage at the nominal discharge current. Higher discharge currents may also occur. The arrester can withstand this undamaged, but it results in a higher residual voltage across its terminals depending on the shape of the  $U-I$ -characteristic (5% to 15% increase for double the current amplitude).

Thus, when choosing an arrester protection level, certain details must be considered, such as the distance between the arrester and the device to be protected, the particular substation configuration or

<sup>1</sup> You are reminded that the *amplitude* of the original voltage surge has no effect on the described procedure provided it is above the protection level of the arrester.

the typical overvoltage stress in the system. If the distances are not chosen too large, a factor of at least 1.4 between the standard rated lightning impulse withstand voltage (LIWV) of the device to be protected and the lightning impulse protection level (LIPL) of the arrester normally leads to safe protection against fast-front overvoltages. In problematic cases, however, for example when [very-fast-front overvoltages](#) are to be expected, or when there are unusually great distances between the arrester and the device to be protected, the protective effect must be individually checked by means of a detailed calculation.<sup>1</sup>

Not only is configuring for stable continuous operation ( $U$ - $I$ -characteristic in the leakage current range) and choosing sufficiently low protection levels ( $U$ - $I$ -characteristic curve in the high current range) necessary, but the arrester must also possess the necessary [energy handling capability](#) for each individual application. In the process, two different aspects must be considered:

The energy, which is instantaneously injected during a single discharge, is not allowed to exceed a value at which the metal-oxide resistors will be thermo-mechanically overstressed. Thus, one speaks in this context of the [single impulse energy handling capability](#) of an arrester. Energy that is injected within only a few micro- or milliseconds causes extreme, sudden temperature rises associated with excessive tensile and compressive forces acting on the MO resistor ceramic. This can lead to fine cracks or even cause the resistors to break. The effect is supported by the smallest inhomogeneities in the ceramic of the MO resistors, which despite the highly developed manufacturing technology are basically unavoidable. They may cause locally limited overheating of the ceramic in case of extremely high current and energy densities, respectively. Since the heat cannot spread fast enough into the surrounding material, additional thermo-mechanical stresses occur. By similar means hot channels may develop at locations of inhomogeneities, leading to electrical puncturing of the resistor. In addition, an external flashover may occur. The single impulse energy handling capability is thus largely a characteristic property of the metal-oxide resistor inserted in the arrester, practically independent of the rest of the arrester design. It is specified by the manufacturer with a sufficient safety margin to the actual limits.

Totally different contexts are valid for the [thermal energy handling capability](#). This is defined as the maximum level of energy injected into the arrester, at which it can still cool back down to its normal operating temperature. **Figure 8** illustrates this problem:

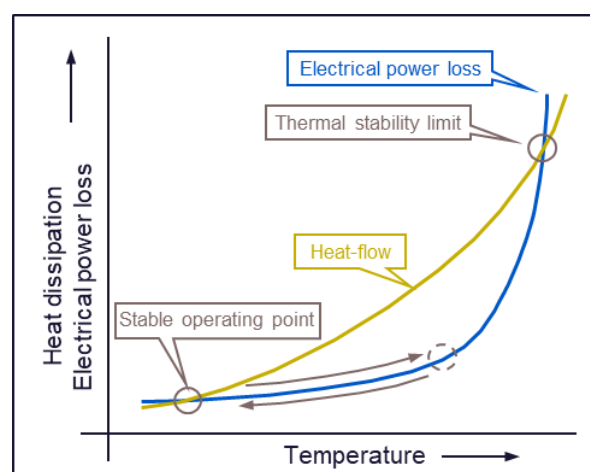

**Figure 8:** Explanation of the thermal stability

<sup>1</sup> For more information see IEC 60071-2 and IEC 60099-5.

The electrical power loss resulting from the continuously applied power-frequency voltage is temperature-dependent. It rises overproportionally as the temperature increases. On the other hand, because of its design, the arrester can only dissipate a certain limited amount of heat into the surroundings. Indeed, this heat dissipation value also rises with the temperature, however, not nearly as much as the electrical power loss does. Both power curves have two common points of intersection. The left one is a stable operating point. At this point exactly as much heat is dissipated to the outside, as is produced in the MO resistor: a thermal balance prevails. A discharge operation disturbs this balance. The energy, which is introduced, increases the temperature rapidly, and the operating point moves to the right on the power loss curve, as is shown with an arrow in Figure 8. As long as the right point of intersection of the curves is not reached, the heat generated by electric power loss can easily be dissipated, and the arrester can return to the stable operating point. If, however, the right point of intersection is reached or exceeded, then cooling is no longer possible. The arrester then becomes thermally unstable and heats up until it self-destructs. This point of intersection, therefore, represents the [thermal stability limit](#). The thermal energy handling capability is specified in such a way that the related temperature increase brings the arrester to a temperature which exhibits an adequate safety margin to the thermal stability limit. The actual thermal stability limit depends both on the electrical properties of the MO resistors and on the overall arrester design and has a value of typically between 190 °C and 220 °C.

Both definitions of the energy handling capability cited above were not specified in the same way in the arrester standard up to IEC 60099-4 Ed. 2.2. Instead, for high-voltage arresters the energy handling capability was only described by means of, what is known as, the [line discharge class](#), which indirectly reflects the thermal aspects of the energy handling capability. Its definition was, however, complicated and ambiguous. IEC 60099-4 Ed. 3.0, released in June 2014, has finally made a clear distinction between impulse and thermal energy handling. However, since there are innumerable arresters in service that are specified by line discharge class, and users need to be familiar with both concepts of defining energy handling capability, the line discharge class system is nevertheless covered in an appendix of this guide.

With respect to the energy handling capability the *current* arrester standard distinguishes between [station class](#) and [distribution class](#) arresters. The *impulse* energy handling capability is defined for both arrester classes via the [repetitive charge transfer rating](#) (symbol:  $Q_{rs}$ ). As such charge transfers are expected to happen not only once during an arrester's service life, the addition "repetitive" is an important detail of the characterization. The *thermal* energy handling capability is defined for station arresters via the [thermal energy rating](#) (symbol:  $W_{th}$ ), and for distribution arresters via the [thermal charge transfer rating](#) (symbol:  $Q_{th}$ ). **Table 1** gives a complete overview of the classification of arresters<sup>1</sup>. A basic distinction is made there between station class (S) and distribution class (D), as already mentioned, and each of these classes is in turn subdivided into high duty (H), medium duty (M) and low duty (L). Each class has a dedicated [nominal discharge current](#) as standard, though other currents may be specified upon agreement between manufacturer and user. The same applies to the specified [switching impulse discharge current](#). The next line of the table gives, for all arrester classes, minimum required values for the repetitive charge transfer rating. Finally, there are minimum requirements for the thermal energy rating for the station arresters and the thermal charge transfer rating for the distribution arresters<sup>2</sup>.

<sup>1</sup> Up to Edition 2.2 of IEC 60099-4 arresters were classified only by their nominal discharge current. Arresters for high voltage transmission systems, for instance, were designated as 20 kA or 10 kA arresters. A further subdivision according to line discharge classes followed. 20 kA arresters could be of line discharge classes 4 or 5, and 10 kA arresters of line discharge classes 1, 2 or 3. See also Appendix 1 of this guide.

<sup>2</sup> This is an inconsistency of the current standard IEC 60099-4 Ed. 3.0 Table 1. The  $Q_{th}$  values are given there as "equal to or larger" ( $\geq$ ) values, but as shown here, fixed values shall be used (see also IEC 60099-4 Ed. 3.0 Table 5).

Table 1: Arrester classification

Arrester class	Station			Distribution		
	SH	SM	SL	DH	DM	DL
Nominal discharge current (kA)	20	10	10	10	5	2.5
Switching impulse discharge current (kA)	2	1	0.5	-	-	-
$Q_{rs}$ (C)	$\geq 2.4$	$\geq 1.6$	$\geq 1.0$	$\geq 0.4$	$\geq 0.2$	$\geq 0.1$
$W_{th}$ (kJ per kV of rated voltage)	$\geq 10$	$\geq 7$	$\geq 4$	-	-	-
$Q_{th}$ (C)	-	-	-	1.1	0.7	0.45

The background of the different definitions of thermal energy handling capability will be briefly discussed here. The greatest demands on the energy handling capability of station arresters arise from the limitation of switching overvoltages. For example, an arrester in a substation must be able to absorb the energy stored in the capacitance of a connected open line when it discharges into the arrester. This usually results in significantly higher energies than those that occur in the substations due to lightning overvoltages. It must be mentioned here that arresters normally are designed to divert to the ground only a fraction of the charge that is introduced to the overhead line conductor as a result of a direct lightning strike. In this case, it is assumed that the overvoltage, which occurs on the overhead line conductor, will cause a flashover of one or more line insulators. The greatest part of the charge is thus diverted through the flashover channels towards the ground. Only overvoltages limited to the insulator flashover voltage and the related currents associated over the surge impedance of the line, with the appropriately reduced charge content, will finally reach the substations, and only these must further be limited by the arresters in the station or their contained charge further diverted to the ground. Typically, this is not a severe duty for a station class arrester. It is thus reasonable to specify mainly *energies* (resulting from switching overvoltages) for station class arresters, as this is related to their main operating tasks.

In medium-voltage distribution systems, however, the arresters are widely spread over the whole network as they are normally directly arranged either, for instance, at the pole-mounted transformers, or at the cable terminations. The arresters' main task here is to divert the full or just a part of the charge, which is brought to the line by lightning strikes, to ground. Therefore they are favorably characterized by their ability to transfer *charge* during a single event. Though the expectation is that the arresters limit overvoltages during charge transfer to values as low as possible, they have of course to absorb energy depending on their own residual voltage (time integral of current times voltage). Hence, energy handling capability is also an issue for distribution arresters, but an arrester that converts less energy than another during charge transfer is the "better" choice for this purpose, and this is why energy handling capability is not an adequate measure to compare distribution arresters with one another. But what has been said before makes it clear that also distribution arresters may suffer from thermal instability during or after the charge transfer, and, therefore, also a thermal charge transfer rating (i.e. the ability to remain thermally stable after a charge transfer) must be specified.

Once in a while, lightning may hit the line so closely to an arrester, that it is only relieved a little or not at all by insulators flashing over. This is known as a [nearby direct lightning strike](#) and a common cause for arrester failures in these systems. Attempts to avoid this in high-voltage transmission systems are made by improving the shielding of the line, for example, by installing a second overhead shield wire next to the substation. That is why nearby direct lightning strikes almost never occur in conjunction with high-voltage station arresters. However, there is practically no way of protecting distribution arresters against a nearby direct lightning strike. As a result their failure rate is generally (but with strong local variations) about one order of magnitude higher than that of station arresters.

## Constructive design of MO arresters

This chapter describes the basic constructive design of MO arresters. From the many possible ways to construct an arrester, only a few examples have been chosen so that the principle is clear.

The fact that there is no longer any need for serial gaps, which were mandatory for the gapped SiC arresters, has simplified the design of arresters considerably. Certain designs of the polymer-housed arresters were in fact impossible to construct until the gapless metal-oxide technique was introduced. As a major progress, MO arresters could be built with only one single effective active element, namely the column of the MO resistors. High demands are, however, made on these MO resistors, as they combine all the functions, which previously had been shared among the different components of the gapped arrester. In this way they have to be ageing resistant while being subjected to the constantly applied operating voltage. They must be able to absorb the energy injected and to divert the charge, respectively, during a discharge, and they should subsequently limit the follow current (leakage current) to values small enough for thermally stable operation. As a result, development of the MO resistors and their manufacturing technology – the production of MO resistors is considerably more complicated than that of SiC resistors – are of particularly great importance. This is not discussed any further here. Only the constructive design of an MO arrester will be dealt with here.

**Figure 9** shows the cross section of a [unit](#) of an MO arrester with porcelain housing to be applied in a high-voltage system. The **MO resistor column**, together with the accompanying supporting construction, comprises the actual [active part](#) of the arrester. The column consists of individual MO resistors stacked on top of each other. The MO resistors are almost always produced in a cylindrical form (**Figure 10**)<sup>1</sup>. Their diameter decisively determines the energy handling and the current carrying capability, respectively, and the protection level. It is within a range of about 30 mm when used for distribution systems, and up to 120 mm for high- and extra-high-voltage systems and special applications, for which high energy handling capabilities are required<sup>2</sup>. For particularly high requirements, active parts are also implemented using multi-column technology, i.e. two or more columns are combined in one common housing or individual arresters are connected in parallel.

---

<sup>1</sup> Some manufacturers also use designs with center holes, forms which are similar to toroids (“donuts”). For low voltage varistors square designs are also common.

<sup>2</sup> Actually the volume of the MO resistor column is the decisive value. But for any given protection level of an arrester the length of the MO resistor column is more or less fixed and the energy handling capability is generally affected by the diameter of the MO resistors.

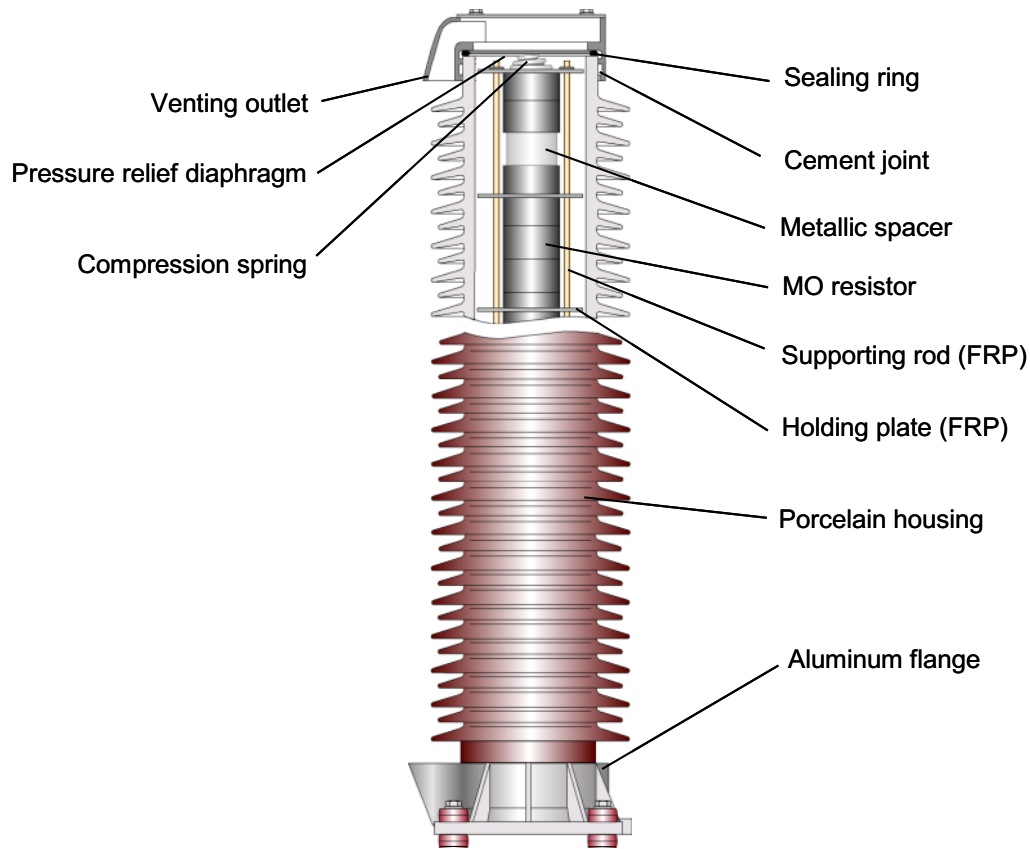

Figure 9: Cross-sectional drawing of the unit of a porcelain housed MO arrester

MO resistors vary in height between ca. 2 mm and 45 mm. For the most part, the height is associated with the production and depends on the available tools and manufacturing facilities. However, not every height can be manufactured, since the greater the height (as well as the diameter), the harder it is to achieve sufficient homogeneity of the resistor material during manufacturing. This, however, decides most of all upon the energy handling capability and even more upon the reproducibility of specified technical data.



Figure 10: Metal-oxide resistors

The  $U$ - $I$ -characteristic of an MO resistor or a complete MO arrester is based on the [field strength-current density characteristic](#) ( $E$ - $J$ -characteristic) of the underlying material system, which is dependent upon

the substances contained and the production technology. It is easily calculated by multiplying the field strength with the relevant height and the current density with the relevant cross-sectional area.

The residual voltage per millimeter of height during a lightning current impulse of 10 kA peak value – the specific 10 kA residual voltage – is within a range of about 450 V/mm for a typical MO resistor in a distribution arrester (32 mm diameter) down to about 330 V/mm for a 100 mm diameter resistor used in extra high-voltage systems.<sup>1,2</sup> Typically, 60 mm diameter MO resistors would be used for an arrester in the 420 kV system. With a standard height of 36 mm and a specific 10 kA residual voltage of 360 V/mm, each individual resistor has a 10 kA residual voltage of about 13 kV. In order to achieve a lightning impulse protection level of 790 kV, as in the example in Figure 2, 61 resistors would have to be stacked on top of each other. The resulting height of the MO resistor column of some 2.2 meters could indeed be contained in a single porcelain housing. However, for dielectric reasons (clearance and creepage distance requirements) the housing must be designed to be considerably longer, so that arresters in the 420 kV network typically consist of at least two units in series. This example shows that the height of the arrester is, in most cases, not determined by the height of the active part.

The length of the active part is fitted to the housing length of the unit by means of **metallic spacers**. In the simplest cases these are aluminum tubes with end covers in order to achieve an evenly distributed contact pressure. Sometimes, however, massive aluminum parts are inserted, which at the same time serve as heat sinks, thereby increasing the thermal energy handling capability of the arresters.

The MO resistors stacked on top of each other in this way have to be mechanically fixed in the housing. The aim is, on the one hand, to ensure that the active part cannot be moved out of its original position during transportation<sup>3</sup>, or when the arrester is installed in a position which is other than vertical. On the other hand, a certain axial contact pressure is necessary, so that the occurring current stresses can be easily handled. Figure 9 depicts one of the many achievable possibilities. Several **supporting rods** out of [FRP \(fiber-glass reinforced plastic\)](#) material encircle the MO resistor column like a cage. **Holding plates** – also out of FRP – additionally provided at regular intervals, on the one hand, prevent the supporting rods from being bent apart, and on the other hand, limit possible sagging of the whole construction towards the housing walls. A strong **compression spring** (for higher requirements, possibly more than one) which is attached to the upper end of the column braces the active part in the housing.

High demands are made on the electrical and mechanical properties of the whole supporting construction. It must be designed and implemented in such a way that it remains free of electric partial discharges under all operating conditions. In addition to high mechanical strength, high temperature resistance and high tracking and erosion resistance, as well as flame retardant and self-extinguishing properties in case of fire are required.

Until well into the 1980s in all cases, and for most high-voltage applications still today – as shown in Figure 9 – **porcelain** was used for the arrester housing. The ends of the housing are equipped with **aluminum flanges**<sup>4</sup>, which are applied with the help of **cement**<sup>5</sup>. When choosing aluminum material of a quality for outdoor use, external paint is not necessary for the flanges.

[Sulfur cement](#) is the first choice for cementing. Besides favorable mechanical properties, it also proves to have advantages over [Portland cement](#), which is quite common in the insulator industry, in the

---

<sup>1</sup> The main reasons for these differences are the different current densities, depending on which diameters are used, based on a current value of 10 kA. The lower the current density, the lower the residual voltage.

<sup>2</sup> MO resistors with over 600 V/mm have also been used for [GIS-arresters](#) for some time. In arresters for outdoor applications, that is in open air under normal atmospheric conditions, such resistors would flash over under the impact of their own residual voltage.

<sup>3</sup> Transport is often responsible for the highest mechanical stress to which an arrester is subjected in its entire "service" life.

<sup>4</sup> Sometimes when mechanical requirements are particularly high, steel flanges are also used.

<sup>5</sup> Designs with clamped-on flanges are also common.

manufacturing process: it can easily be brought into contact with aluminum without causing corrosion, and it can be quickly processed, since directly after application it already almost reaches its mechanical final strength.

Assuming the flanges and the end sections of the porcelain housing are appropriately designed, it is possible to achieve a cement joint that is always mechanically stronger than the porcelain itself. That means that the strength of the porcelain can fully be made use of, when specifying the permissible mechanical head loads of the arrester housing.

Insulator porcelain is manufactured in different qualities, for which the minimum requirements are found in standards, e.g., IEC 60672-3. Two qualities are generally used today for arrester housings: the [alumina porcelains](#) of subgroups "C 120: aluminous porcelains" and "C 130: aluminous porcelains, high strength"<sup>1</sup>. Higher mechanical strength can be achieved with porcelains from subgroup "C 130", which have a specific mechanical strength that is around 50% higher than that of subgroup "C 120". One important influence on the mechanical strength is the glaze, which is applied not only to the outside, but also to the inside of the porcelain walls. The strength of the housing naturally depends greatly on the geometry of the porcelain as well. Not only the wall thickness, but also the diameter play an important role here. The higher the system voltage, and as a result the greater the requirements on mechanical strength, the greater the diameter of the porcelain that will be chosen<sup>2</sup>.

The color of the glaze, however, has no technical significance. The most common color is brown (color RAL 8016). Frequently, however, especially in the Anglo-American regions, a light gray tone is preferred. A certain influence of the color on the inner-arrester temperature, because of different thermal emittance and absorption coefficients, can be theoretically derived. Its total effect, however, remains negligible, such that for practical purposes, it is not taken into consideration.



**Figure 11:** Alternating shed profile (left) and normal shed profile (right)

Besides protecting the active part from environmental influences, the arrester housing above should also provide an adequate [creepage distance](#). For this reason it is equipped with sheds whose designs can differ greatly. For the design of the shed profile (distances, overhang, angle of inclination) the application guide series IEC 60815 makes recommendations which should be followed by the manufacturer. The most noticeable is the difference between an alternating and a normal shed profile (**Figure 11**). No general recommendation can be made about which of the two types is more preferable. The advantages of the alternating shed profile include the prevention of continuous conductive layers from appearing on the surface, and that a large ratio of the creepage distance to the total length can be achieved, which at any creepage distance requirements leads to shorter arrester housings. In artificial pollution tests in salt fog (in accordance with the standard IEC 60507), it generally performs better than the comparable normal shed profile. The latter, on the other hand, proves to have

<sup>1</sup> In the past, [quartz porcelain](#) (subgroup "C 110: siliceous porcelains") was also used.

<sup>2</sup> A bigger porcelain diameter can also be appropriate for reasons of short-circuit withstand capability and of the operational performance under polluted conditions. In brief: bigger diameters cause, on the one hand, stronger electric discharge activities on the surface, which, on the other hand, have less thermal impact on the arrester's active part due to the large distance and consequently small coupling capacitances between the outer surface and the MO resistors. Also internal radial electric field stress and thus the risk of inner partial discharges is much lower for bigger housing diameters.

particularly good self-cleaning properties under real service conditions, and as a result, in many cases it has an excellent service record. In case of doubt when choosing a shed profile, the user's individual operational experience at a specific site should be considered.

The commentary to Figure 9 concludes with a description of the sealing system. This is one of the most critical components of the arrester; the type of failure in arresters most frequently mentioned in arrester literature and by users is leakage. The sealing system has three tasks to fulfill, which are quite incompatible with each other. On the one hand, it must deter the ingress of moisture for the duration of the lifetime of the arrester – the duration is meant to be 25 to 30 years. On the other hand, it should act as a fast operating pressure relief device in the rare event of an arrester overload, which can cause a rapid build-up of pressure in the housing, and would otherwise lead to a violent shattering of the porcelain body. Finally, at this point, a well-defined electric current transfer from the flange to the MO resistor column must be established.

The example shown in **Figure 12** consists of a sealing system, which for the most part is made up of a **sealing ring** and a **pressure relief diaphragm**. Both elements appear twice, that is at each end of the housing. The sealing ring is attached to the end face of the porcelain body. When the sealing occurs at this point then the cement between the flange and the porcelain is not part of the sealing system. This reduces the requirements on the cement bonding, but requires absolute care when working the porcelain end faces and during the subsequent quality control.

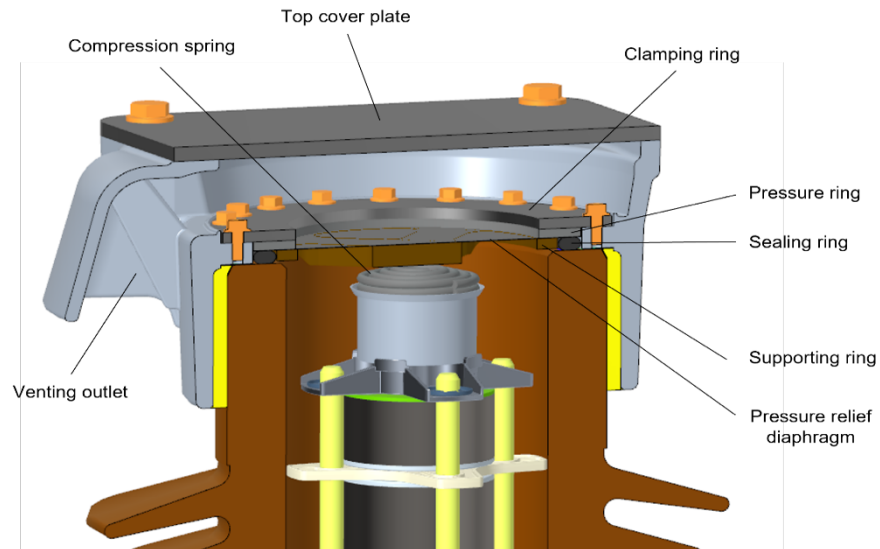

**Figure 12:** Sealing system of a high-voltage porcelain housed MO arrester

Great demands are made most of all on the material of the sealing ring. Thus, for example, natural rubber proved to be unsuitable, since with time it becomes brittle. Resistance to ozone is another elementary requirement, which nowadays can be fulfilled with the use of synthetic materials.

The pressure relief diaphragm, which is used in this arrester construction, consists of very pure high grade steel or nickel material, which is only a few tenths of a millimeter thick. In terms of the design and the quality assurance, it is challenging to make the diaphragm resistant to corrosion for a period of 30 years. The diaphragm is pressed against the sealing ring with a metal **clamping ring** screwed to the flanges. It is especially important to make certain that only compatible (with respect to electro-chemical processes) material combinations are used. Otherwise gap corrosion will definitely result, which sooner or later will lead to leakages.

The particular advantage of the pressure relief diaphragm<sup>1</sup> is its extremely short opening time in the case of an arrester overload. An arrester overload is a very infrequent occurrence<sup>2</sup>. It cannot, however, in principle be ruled out, not even in the case of an overdimensioned arrester. Possible causes for this are, for example, direct lightning strikes occurring near the arrester, or power-frequency voltage transfer from a higher to a lower voltage system, for example, on a transmission line with several voltage levels which cross each other because of a conductor failure or galloping. In such a case an overload of one or several of the MO resistors occurs in the affected arrester. A partial arc builds up, which in split seconds turns into a complete arc between the two flanges inside the housing. The full short-circuit current of the net, which appears where the arrester is actually installed, flows through this arc (root-mean-square value up to about 80 kA, peak value up to about 200 kA). As a result, an abrupt increase in pressure develops within the housing. At the same time, the pressure relief diaphragm tears open within a few milliseconds, thereby ensuring a safe pressure relief before the bursting pressure of the housing is reached. The hot pressurized gases very rapidly escape from the inside of the housing through the two **venting outlets** ("venting" of the arrester). Outside the housing the two gas streams meet and cause the arc that was burning inside the housing, to commute and continue burning outside the arrester, until the failure has been cleared. Up to that point, breaking of the porcelain<sup>3</sup> can still occur as a result of the extreme thermal stress. However, because of the practically unpressurized decay, no other serious damage can ensue.

When the arc burning inside the housing is quenched as a result of a system fault clearing, which already occurs before the opening of the pressure relief diaphragm, or when the pressure build-up occurs relatively slowly, because of a very low fault current (which occurs especially in resonant earthed neutral systems), the pressure relief diaphragm does not rip, but instead only pulls wrinkles, which (in this case, intentionally) leads to leakage<sup>4</sup>. This makes it impossible for a failed arrester to be under internal pressure of more than one bar and greatly reduces the security risks when dismantling a defective arrester.

The most important components of an MO arrester have been described above, employing a high-voltage arrester with porcelain housing as an example. However, a few other details are necessary to complete the description of a high-voltage arrester (**Figure 13**).

---

<sup>1</sup> Other types of pressure relief devices are also common, for example, spring loaded covers.

<sup>2</sup> In high-voltage transmission systems this occurs considerably less than in medium-voltage distribution systems.

<sup>3</sup> A so-called thermal or secondary breaking, which is expressly permitted according to the arrester standards.

<sup>4</sup> Such a defective arrester is recognizable from the outside by the heavy layer of black carbon on its housing.

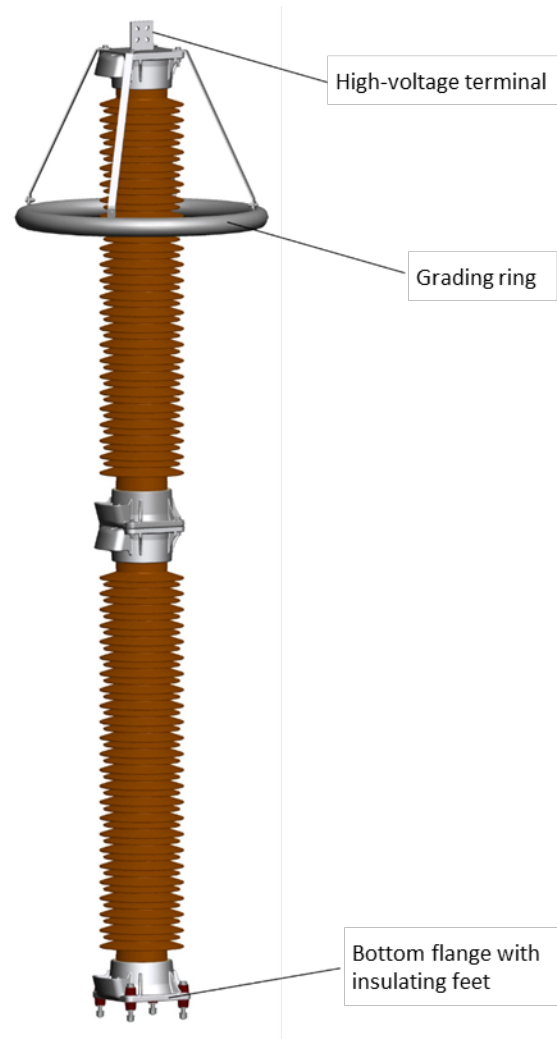

Figure 13: Two-unit high-voltage arrester

It has already been mentioned that starting at a certain length of the MO resistor column, an arrester is no longer manufactured in one piece. The longest a porcelain housing can reasonably be, is, for technical and economic reasons<sup>1</sup>, about two meters. At this length an arrester can be accommodated in one single unit for a solidly earthed neutral 245 kV system, as long as creepage distance requirements are not higher than average. At all higher voltage levels, the arrester must consist of several units, for example in a 420 kV system it would have at least two parts. At the higher voltage levels or when there are extreme creepage distance requirements, it can also be made up of three, four or five parts. In principle, there is no upper limit, as long as the arrester still proves to have sufficient mechanical properties.

Starting at a length of about two meters on up, and usually for arresters made up of several units, [grading rings](#) are absolutely essential. These serve to control the [voltage distribution](#) from the high-voltage end to the earth end, which is unfavorably influenced by the earth capacitances affecting the arrester. Without the appropriate countermeasures the MO resistors at the high-voltage end of the arrester would be stressed considerably more than those at the earthed end, resulting in potentially excessive heating. Grading rings differentiate from each other in terms of their diameters and in the lengths of their fixing braces. The rule of thumb in this case is as follows: the larger the diameter and

<sup>1</sup> One of the reasons is that the longer the housing, the lower the short-circuit withstand capability becomes. Another is that most porcelain insulator manufacturers cannot fire the greater lengths in one piece.

the longer the braces, the better the control effect is on the voltage distribution. At the same time there are two reasons for keeping both of the sizes mentioned small, if at all possible:

- The relevant standards on erecting electrical power installations<sup>1</sup> stipulate a minimum distance between the conductors of the neighboring phases. These requirements are also valid for the distance between the grading rings of two neighboring arresters. The smaller the grading ring, the smaller the centerline spacing of neighboring arresters can be, and thus the bay width to be selected.
- The fastening braces cannot be lengthened to whatever size desired, since the empty arrester housing must fulfill certain withstand voltage requirements. If the braces are too long, flashovers may occur from the grading ring over the neighboring flange to the earth, or directly to the earth, especially while testing with [switching impulse voltage](#).

Users sometimes regard grading rings as an inconvenience because they occupy space in the switchyard. However, it is extremely important to ensure that the grading rings specified and supplied by the manufacturer are installed. If this is not done, thermal instability with resulting failure of the arrester may occur.

Grading rings must not be confused with [corona rings](#), which are sometimes specified for extra-high voltages in order to provide an electrostatic shield for the terminals so as to adhere to the maximum permitted [radio interference voltage](#) values.<sup>2</sup>



**Figure 14:** Arrester with insulating feet, current sensor and control cubicle

High-voltage station arresters are usually not directly earthed; instead monitoring devices, such as [surge counters](#), [monitoring spark gaps](#) or [leakage current indicators](#) are connected with the arrester in series. In this case insulation is provided for by setting the arrester up on **insulating feet** (Figure 13, **Figure 14**). Earthing then occurs through the appropriate monitoring devices. The insulating feet must be mechanically designed in such a way, that they can withstand long-term as well as short-term mechanical forces affecting the arrester. They must have adequate electrical strength, so that they do

---

<sup>1</sup> For example, the European harmonization document HD 637 S1, or the standard IEC 61936-1: Power installations exceeding 1 kV a.c. – Part 1: Common rules.

<sup>2</sup> See the section entitled “Grading ring” in the appendix for more details about grading rings and corona rings.

not flashover under the stress of the voltage drops across the monitoring devices situated in parallel and caused by the self-inductance of the ground connection.

The ground connection lead should have a cross section of at least 35 mm<sup>2</sup>, less for electrical reasons – for this a smaller value would be entirely adequate – than for reasons of mechanical strength and resistance against environmental impact.

The **high-voltage terminal** serves as the connection to the overhead line conductor. Normally bolts and flat terminals are used (**Figure 15**). Their design and dimensions are standardized, for example in accordance with [DIN](#) or – in the United States – with [NEMA](#). However, special customer-specific variants are also common.

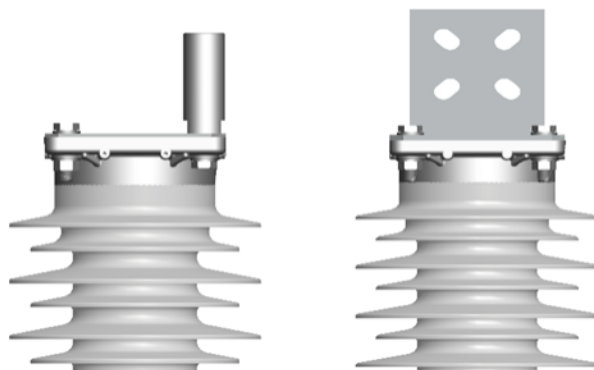

**Figure 15:** Bolt terminal (left) and flat terminal (right)

The following pictures (Figures 16...18) show other models of MO arresters: a medium-voltage distribution arrester with polymer housing and two different designs of high-voltage arresters with polymer housing. The chosen examples differentiate from each other, in some cases greatly, in their design features, and thus provide an overview of some of the basic arrester designs in use. Medium-voltage arresters with porcelain housing are not discussed in more detail here as they have been almost completely superseded by arresters with polymer housing. Millions of them are nevertheless still in use. The appendix contains a [diagram](#).

Due in large part to the failures caused by leakage in cheaply designed distribution arresters with porcelain housings, the first ones equipped with polymeric outer insulation appeared on the market in the mid 1980's. Their most remarkable design feature is the polymer housing located directly on the MO resistor stack. As a result, the gas-filled gap between the MO resistors and the housing no longer exists, and with the appropriate constructive realization of the interface between the polymer housing and the end fittings, a sealing system can be completely omitted. Similarly, in case of an overload, a pressure buildup and the related risk of housing breakage can be avoided. Nevertheless, a number of different designs are possible based on this principle<sup>1</sup>.

In the case of a porcelain insulator, different properties – such as, protection from environmental impact and provision of sufficient creepage distance on the one hand, and mechanical strength on the other – are united in a single component. In an arrester with polymer housing, however, these properties are apportioned to two different components. Mechanical strength is, virtually without exception, achieved with fiber-glass reinforced plastic (FRP) materials. In the example shown in **Figure 16**, several rods serve this purpose. They are strained, e.g. by crimping, in the end fittings and enclose

<sup>1</sup> Note that the arresters built according to this principle are not “per se” moisture tight and break resistant in case of overloading, as was anticipated in the beginning. With these arresters specific design characteristics and the quality of manufacturing also continue to play an important role.

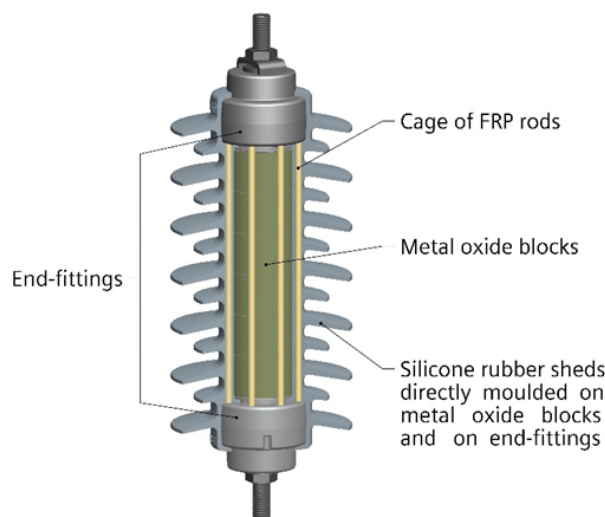

**Figure 16:** Cross-sectional drawing of a polymer-housed MO distribution arrester

the MO resistor stack like a cage. That is why the term “cage design” is often used in this context<sup>1</sup>. Here, the MO resistors themselves form part of the mechanical structure. This is how a mechanical high-strength unit out of MO resistors, end fittings and the FRP structure are created. This module is inserted in a mold, in which silicone rubber is directly injected. With the appropriate manufacturing techniques, it is possible to obtain a perfect bond of the silicone rubber with the other components, void-free and permanent. The final product is all of a piece. One advantage of the applied silicone rubber in this case, in comparison to cheaper materials, which are also used, is the excellent endurance properties – by now, it is possible to fall back on about 50 years of service experience in this area. Another advantage is a characteristic unique to silicone rubber, [hydrophobicity](#): even if the silicone surface is heavily polluted, water simply drips off. This suppresses the formation of conductive layers and advantageously affects the operational performance of the arrester in polluted conditions.

The risk of the housing bursting and splitting in case of an arrester overload for the design shown in Figure 16, is nonexistent. The arc resulting from a puncture or a flashover of the MO resistors rips the silicone rubber housing open, and with almost no resistance, finds its way outside.

The advantages of such an arrester design have only been hinted upon here. The combination of the given weight reduction in comparison to a porcelain housing, the ease of handling during transportation and installation, and last but not least, the savings in cost that manufacturing such an arrester offers in comparison to an arrester with porcelain housing, present advantages which make it clear why the polymer-housed arresters within the medium voltage range have become so popular. As a result, it is also apparent why the devices with porcelain housings have, in this case, virtually disappeared from the market.

<sup>1</sup> Another common version uses mats or bands wrapped onto the MO resistors. After the resin within these mats is cured, it forms a stiff tube which directly bonds to the MO resistors. This design is often called the “wrapped design”.

A peculiarity of distribution arresters is their frequent application in connection with [disconnectors](#). This additional device can be not only integrated in the arrester, as depicted in **Figure 17**, but also be attached to its outside, and is often of great importance for a trouble-free operation of a distribution network. Here the locations of the arresters are not limited to only a few switchyards or substations, as in a high-voltage transmission system. Instead arresters are distributed throughout the whole net (pole stations, cable terminations), and in many cases an arrester which has broken down is not noticeable

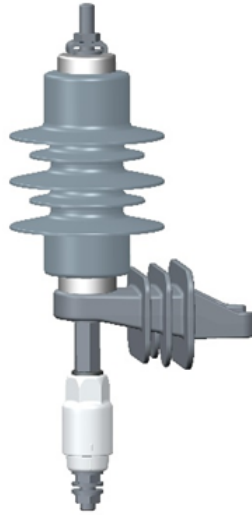

**Figure 17:** Polymer-housed MO distribution arrester with disconnector and insulating clamp

within this great spatial expanse. And even if it is, replacements cannot always immediately be made. The disconnector is supposed to ensure that, after a possible failure, the arrester is separated from the network. Otherwise the arrester could, after such an incident, form a permanent earth fault. In that case, the arrester must obviously be fitted with an insulating clamp as shown in Figure 17. The insulating clamp is dimensioned to withstand the line-to-earth voltage (after failure, the arrester is practically a short-circuit) for a certain period – a requirement that is not always easy to meet. It should, however, also be mentioned that the disadvantage of a disconnector is that as a result of using it, arrester failures may remain unnoticed, and overvoltage protection at this point might unintentionally not be attained. Therefore, for the use of disconnectors no general recommendations can be given. They are used less frequently or sometimes not at all in resonant earthed neutral systems, which can be operated over longer periods of time under earth fault conditions. They are, however, used more frequently in solidly earthed neutral systems. Individual cases depend greatly upon the system management of the different utilities.

The principle of the cage design has also been applied to high-voltage arresters. See **Figure 18** for an example. To achieve adequate mechanical strength and a high short-circuit withstand capability, the

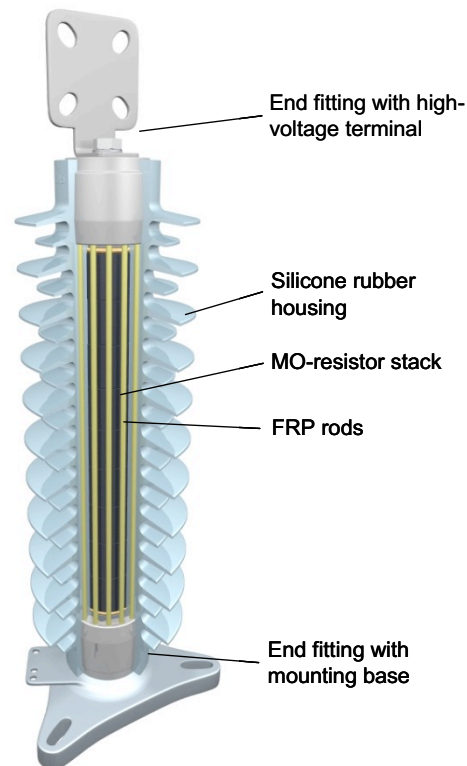

**Figure 18:** Cross-sectional drawing of a polymer-housed MO high-voltage arrester of “cage design”

FRP cage contains considerably more rods than on a medium-voltage arrester. Otherwise, the design features are the same. To use this design with higher voltage levels, multiple modules are simply lined up.

It is significantly more difficult for this design to meet the mechanical requirements at the extra-high voltage levels and the new ultra-high voltage levels (UHV:  $U_s > 800$  kV) in particular. For example, the deflection under load is no longer trivial and may cause problems. Above a certain overall length, the arrester can only be installed in a suspended position with a moving support. In addition, the high voltage levels often require a number of MO resistor columns to be connected in parallel, which can be very costly because entire arresters, together with their housing, must be arranged alongside each other. In this case, a structure that was introduced in the late 1980s may be used, as illustrated in **Figure 19**. This high-voltage arrester with polymer housing uses a composite hollow core insulator, as used with instrument transformers and bushings. To distinguish this design from other arresters with polymer housing, it is also known as the “tube design”. One notices immediately that, in principle, this has the same design as the one in Figure 9. Indeed, essentially only the porcelain insulator has been replaced with a [composite hollow core insulator](#). The composite hollow core insulator is made up of an FRP tube on which the sheds – practically only ever made out of silicone rubber – are [directly molded](#) on, or [pushed on](#) and [vulcanized](#) in the form of individual prepared sheds. This design principle offers some considerable advantages for applications up to the highest voltage levels. Since the inner structure of an FRP tube (for example, relative content of glass fibers, or the winding angle of the fibers), its wall strength and its diameter can, within a large range, be selected without restrictions, such a tube can be endowed with almost any mechanical property. As a result, to name just a few, it can be optimized with respect to tensile strength, bending strength, or internal pressure strength. Thus, it is possible to design high-voltage arresters, which are so mechanically strong, that they can endure the most severe earthquakes intact and at the same time be used as a post insulator in a substation.

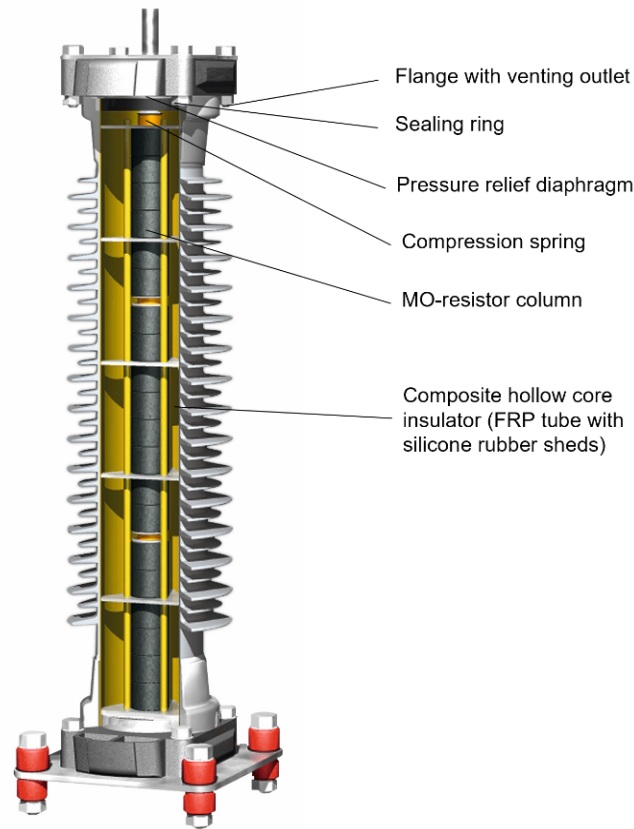

**Figure 19:** Cross-sectional drawing of a polymer-housed high-voltage arrester of "tube design"

The application last mentioned is of benefit to another property only found in this design: in the case of an arrester overload, it is certain that with this construction a housing breakage will never occur; not even any of the inner parts will be ejected. The tube will remain almost completely intact, and as a result it offers the best possible safety for the whole switchgear in a substation (see also the section on designing arresters).

The higher costs of the composite hollow core insulator of such a design, in comparison to porcelain insulators, has long been an obstacle to its being further distributed. As distribution of composite hollow core insulators increases, along with the corresponding market supply, a resulting acceptance of the technology is likely to change the situation in favor of this technology. Anyway, in certain applications, independent of the costs, this design is virtually without alternatives.

To conclude, current development trends clearly point to polymer-housed arresters at all voltage levels. At medium voltages, the process is more or less complete. At the high and extra-high voltage levels, these changes will take more time because the investment costs are higher and the acceptance of new technologies is generally lower (due to the higher risks). However, even in this area, the proportion of polymer-housed arresters is growing at the expense of porcelain housings, thanks to the obvious cost and technology benefits.

## Configuring MO arresters

In order to configure an MO arrester, it is first of all necessary to understand how the different requirements and parameters affect the operational performance of the arrester. With knowledge of the basic principles and interdependencies, it is then possible to lay out an appropriate arrester for less common applications. This chapter describes the general approach and concludes with simple sample calculations to select typical arresters for overvoltage protection in a.c. distribution and transmission systems at voltage levels between  $U_s = 24$  kV and  $U_s = 550$  kV. The arresters are always connected phase-to-earth ("phase arrester"). The configuration of arresters in order to protect the neutral point of a transformer ("neutral point arrester") is also discussed briefly.

The description is given only in view of the device, in other words, so that the question of how an arrester should be configured is answered in a way that, on the one hand, it fulfills its protection requirements and on the other, does not become a problem itself. However, the application will not be discussed here, as to where in the system or on which equipment the arrester should be applied to. For this, the appropriate IEC publications 60071-1 and 60071-2 on insulation coordination or the selection and application recommendations for surge arresters, IEC 60099-5, can be consulted.

This chapter refers to the relevant international standards for testing and application of metal-oxide surge arresters without gaps: IEC 60099-4 and IEC 60099-5. The corresponding American (IEEE) testing standard C62.11 and application guide C62.22 are listed at the end of this handbook, but they are not used here. They continue to differ in some respects more or less significantly from the relevant IEC publications, although efforts are underway to harmonize the two sets of standards.

For the most part, the requirements for an MO arrester can be traced back to two basic requirements. On one hand arresters should provide adequate protection, and on the other they should be laid out for stable continuous operation. Adequate protection means that overvoltages at the device to be protected must always remain below its withstand voltage, with a sufficient safety margin. Stable continuous operation means that the arrester must be able to handle all long-term, temporary or transient power-frequency stresses which result from network operation, while remaining electrically and thermally stable under all conditions.

Both basic requirements cannot be fulfilled independently. A reduction of the protection level automatically means a higher specific electrical stress during continuous operation, and conversely, the continuous operating voltage of an arrester cannot be increased arbitrarily without raising its protection level as well. Both operating points are – at least for a given type of MO resistor – strictly associated with each other through the voltage-current ( $U-I$ ) characteristic curve.

Additional requirements involve the electrical characteristics of an arrester: they should not change during its life span, and insensitivity to environmental influences, such as pollution, solar radiation or mechanical strain, must be maintained.

In **Figure 20** a flow chart illustrates an approach to configuring an arrester. In this case a high-voltage arrester is depicted, since, in comparison to a distribution arrester, more and higher demands are made here. The steps shown in the picture will be discussed below in more detail in the sequence in which they are carried out.

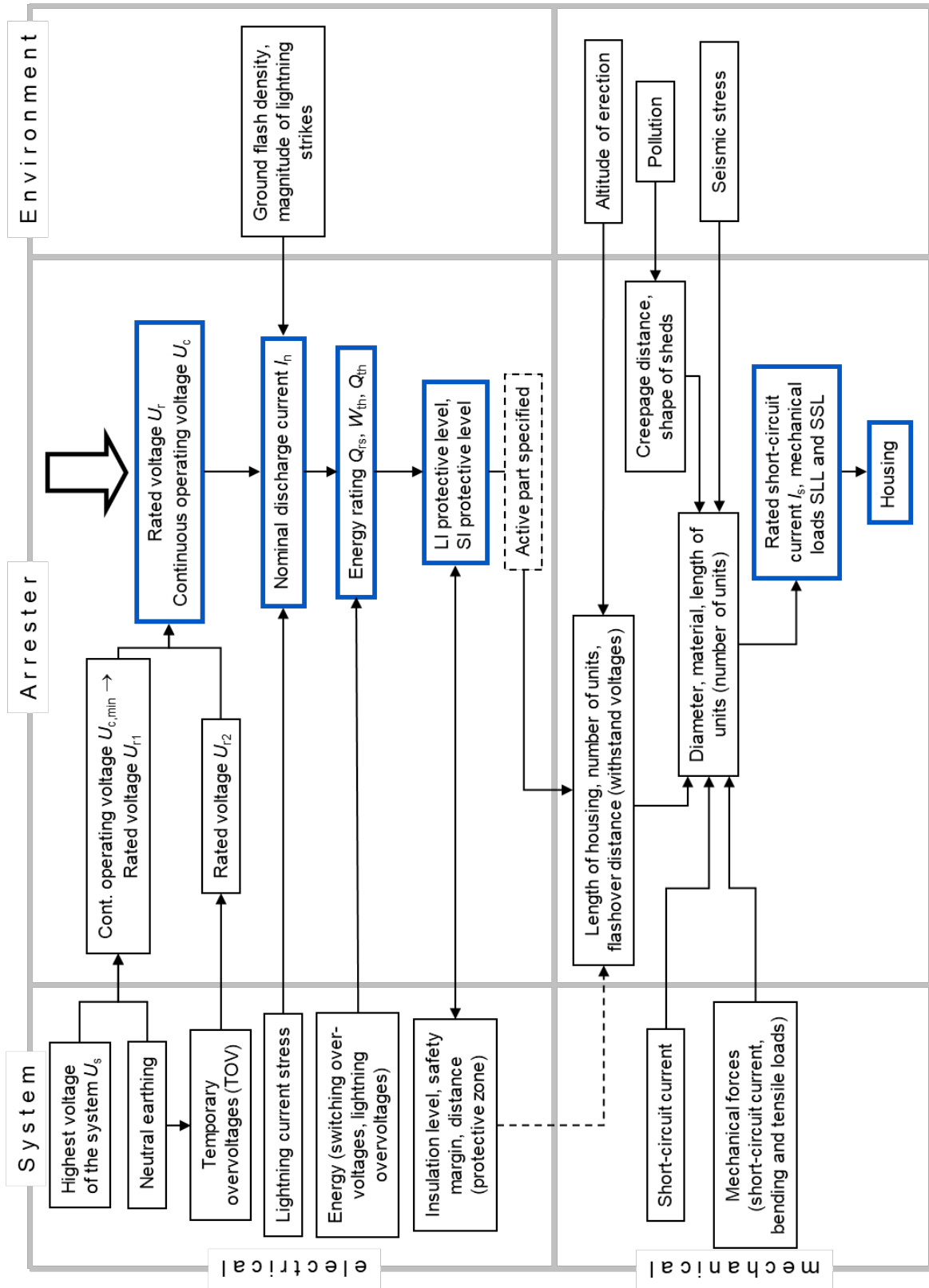

Figure 20: Procedure for configuring an MO arrester

## Choosing continuous operating voltage $U_c$ and rated voltage $U_r$

So that the arrester can protect safely, it must be able to work absolutely soundly in continuous operations. Thus, the first step is to establish a minimally required continuous operating voltage  $U_{c, \min}$ . As already mentioned in connection with Figure 2, this must be as high as the continuous phase-to-earth voltage of the system, provided with at least an additional 5%. The allowance takes into account possible harmonics in the system voltage, which may increase its peak value<sup>1</sup>.

Here “continuously” applied voltage means every voltage that occurs within an uninterrupted period of more than 60 minutes. For this reason to determine the continuous operating voltage, the type of neutral earthing of the system is decisive. In isolated or resonant earthed neutral systems<sup>2</sup>, the voltage of a healthy phase against ground takes on the value of the phase-to-phase voltage in the case of a one-phase earth fault (earth fault factor  $k = 1.73$ ). Since resonant earthed neutral systems are operated quite commonly for time periods of more than 60 minutes in this condition, the continuous operating voltage of the arrester must, in this case, have the value of the highest voltage of the system,  $U_s$ . Only the additional five percent is not taken into consideration here:

Solidly earthed neutral system:

$$U_{c, \min} \geq 1.05 \cdot U_s / \sqrt{3}$$

Isolated or resonant earthed neutral system:

$$U_{c, \min} \geq U_s$$

With the pre-selection of the minimally required continuous operating voltage, a factor which usually has a value of 1.25<sup>3</sup> – there are, of course, exceptions – helps in achieving a rated voltage  $U_{r1} = 1.25 \cdot U_{c, \min}$ . This is the lowest necessary, though not final, rated voltage of the arrester:

Solidly earthed neutral system:

$$U_{r1} \geq 1.25 \cdot 1.05 \cdot U_s / \sqrt{3}$$

Isolated or resonant earthed neutral system:

$$U_{r1} \geq 1.25 \cdot U_s$$

It is clear from these two relationships that the minimally required rated voltage of an arrester in the solidly earthed system is 76% of the (phase-to-phase) system voltage or 125% in an insulated or compensated system. The required rated voltage can, however, also be reached by taking a completely different approach, namely by examining the temporary overvoltages which may occur in the system. The special case of a system, which is operated with a resonant earthed or isolated neutral, and in which the temporary overvoltages are directly decisive for the continuous operating voltage, has already been mentioned. On the other hand, in the case of solid neutral earthing, the temporary overvoltages may reach values of up to 1.4 times the maximum phase-to-earth voltage (earth-fault factor  $k \leq 1.4$ ) for a time period from a few tenths of a second to up to several seconds. Power-frequency voltage above its continuous operating voltage can only be applied to an arrester for a limited period of time: the higher the voltage, the shorter the permissible time of application is.

<sup>1</sup> Because of the extreme non-linearity of the  $U$ - $I$  characteristic, the r.m.s. value of power-frequency voltage plays less of a role than its peak value, which can overproportionally increase the resistive component of the leakage current periodically at the moment of the voltage peak.

<sup>2</sup> Resonant earthed neutral systems are mainly found in central Europe, from the medium voltage range up to the 170 kV level. Systems at higher voltage levels in general have solidly earthed neutrals.

<sup>3</sup> There are no direct physical reasons for the value of 1.25; it was a purely empirical result, which occurred during the manufacturer-independent development of practically all types of MO arresters.

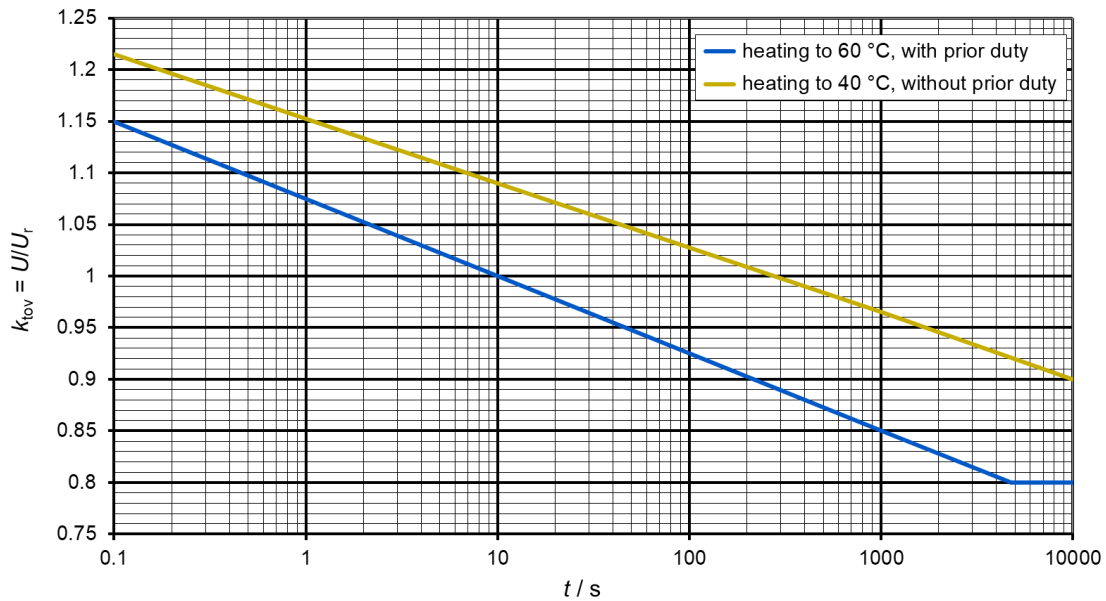

Figure 21: Example of a power-frequency voltage versus time ( $U$ - $t$ ) characteristic

This correlation is depicted in the [power-frequency voltage versus time](#) or  $U$ - $t$ -characteristic (Figure 21)<sup>1</sup>. This indicates the ratio of the permissible power-frequency voltage and the rated voltage  $U_r$ , both given as r.m.s. values, over time, represented in logarithmic standards. The ratio is called here the factor  $k_{toV}$ . For the blue curve in Figure 21 it is assumed that the arrester is in an unfavorable state, that is, that the arrester has previously been heated up to 60 °C, and directly before the application of power-frequency voltage it had to absorb its full rated thermal energy<sup>2</sup>. From Figure 21 it is clear that under these conditions the rated voltage  $U_r$  may be applied for a time period of 10 seconds. The one-second-voltage is, on the other hand, 7.5% above the rated voltage, and the hundred-millisecond-voltage already 15% above. While the blue curve represents the worst case, for which the type tests are also carried out, the orange curve stands for easier conditions. The pre-heating here has been only to 40 °C, and no energy was introduced prior to the temporary overvoltage. If it is certain that these simplifications apply, this curve – or, depending on actual conditions, an interpolated curve between the blue and the orange one – can also be used for the design of the arrester. In the following (and in the examples later in this book), however, the most unfavorable case is assumed. The  $U$ - $t$ -characteristic is applied in the following manner: the voltage value  $U_{toV}$ , which occurs in a system for a time period of 1 s, would, for example, be known. This voltage value must correspond, according to the  $U$ - $t$ -characteristic curve (Figure 21), to 1.075 times the arrester-rated-voltage ( $k_{toV} = 1.075$ ). In other words, the possibly chosen rated voltage of the arrester,  $U_{r2}$ , is the occurring one-second-voltage value divided by a factor  $k_{toV}$ , which is valid for a time period of one second, in this case, therefore,  $U_{r2} = U_{1s} / 1.075$ . In general this reads as:

Solidly earthed neutral system:

$$U_{r2} = U_{toV} / k_{toV}$$

If further sets of temporary overvoltage values and the time of their occurrences are available as a result of knowing the systems conditions, then for each one the corresponding rated voltages must be determined separately. If no information is available at all, then in the case of a solidly earthed neutral,

<sup>1</sup> The  $U$ - $t$ -characteristic shown in Figure 21 is just one of several possible representations and is sufficient for the explanations at this point. For further details see the information on the [power-frequency voltage versus time characteristic](#) in the Appendix “MO Arresters in Brief”.

<sup>2</sup> These are the standard test conditions in the [operating duty test](#).

an earth-fault factor of 1.4, and a time period of ten seconds should be assumed for the occurrence of temporary overvoltages. The highest value of the different rated voltages determined from the temporary overvoltage conditions as described above, is the rated voltage  $U_{r2}$  in Figure 20. Only a small step is now needed to determine the final rated voltage of the arrester –  $U_r$  is the higher of the two values  $U_{r1}$  and  $U_{r2}$ , rounded up to the next highest value divisible by three<sup>1</sup>:

$$U_r = \max \{U_{r1}, U_{r2}\}$$

rounded up to a value divisible by three

If the rated voltage  $U_{r2}$  is greater than  $U_{r1}$ , then the continuous operating voltage must obviously be redefined:

$$U_c = U_r / 1.25$$

After determining the continuous operating voltage and the rated voltage in this way, the arrester is then generally designed not only for a stable normal continuous operation, but also for all temporary overvoltage conditions in the system. It is, however, recommended that a somewhat higher rating than the described minimal rating is selected, as long as the protection level of the arrester does not, as a result, become unjustifiably high. In most cases the protection level requirements allow for this<sup>2</sup>. A higher rating increases the stability of the arrester and provides additional safety, for example in a heavily polluted environment, or when unexpectedly higher temporary overvoltages occur. For this reason one normally finds arresters in the systems which have continuous operating and rated voltages higher than the minimally required ones. However in each case this greatly depends on the utility's individual system management.

### Selecting the nominal discharge current $I_n$

The nominal discharge current  $I_n$  serves to classify an MO arrester. From a technical point of view it is calculated from a typical maximum lightning current amplitude that can be expected in the substation, for which the insulation coordination is performed via the arrester's lightning impulse protection level. This amplitude is calculated from the flashover voltage  $U_{fo}$  of the line insulators, the lightning impulse protection level  $U_{pl}$  of the arresters and the surge impedance  $Z$  of the line as  $I_{max} = (2 \cdot U_{fo} - U_{pl})/Z$ . In this equation, the factor 2 reflects the fact that according to the rules of traveling wave processes, the lightning current reaching the substation nearly doubles in the arrester because the arrester is approximately equivalent to a short-circuited line termination (with a constant voltage source in series). Here is a worked example for a 420 kV system:  $U_{fo} = 2.7 \text{ MV}$ <sup>3</sup>,  $U_{pl} = 790 \text{ kV}$ ,  $Z = 350 \text{ } \Omega \rightarrow I_{max} = 13.2 \text{ kA}$ .

IEC 60099-4 currently specifies four different possible values as [standard nominal discharge current](#), namely 20 kA and 10 kA for station class arresters and 10 kA, 5 kA and 2.5 kA for distribution class arresters (see also [Table 1](#)). These values, however, do not directly reveal anything about the operating characteristics. Thus, for example, a 10 kA arrester can readily withstand lightning current impulses of

<sup>1</sup> The standard IEC 60099-4 refers to steps in which the rated voltages are to be stated. These are between 1 kV and 24 kV, depending on how high the rated voltage is. This system dates back to the days of gapped silicon carbide arresters, while today there is no real technical reason for it. Other steps are permitted, therefore. Currently finer steps, e.g. 3 kV, are typically offered for the highest rated voltages.

<sup>2</sup> An exception is found in the systems at the highest voltage levels,  $U_s \geq 550 \text{ kV}$ . Demands for lower switching impulse protection levels normally limit the amount that the rated voltage can be raised above the minimally required value. Also see the examples at the end of this chapter.

<sup>3</sup> For this worst-case consideration the 100% flashover voltage for negative polarity has to be assumed. The value of 2.7 MV results from a specific flashover voltage of  $U'_{100, \text{neg}} = 770 \text{ kV/m}$  and an insulator length of 3.5 m.

higher amplitudes without sustaining damage. Defining a realistic nominal discharge current is particularly important, though, because it influences the entire process of the insulation coordination in the power system under consideration. After all, the lightning impulse protection level (LIPL) of the arrester is not specified as the residual voltage at a fixed current value in kA, but as the residual voltage at the selected nominal discharge current. So if a LIPL = 790 kV (at  $I_n = 10$  kA) is defined with the example arrester with the  $U-I$ -characteristic shown in Figure 2, the entire insulation coordination is based on this protective value. However, if the lightning impulse currents in the system are actually much higher, e.g. 20 kA instead of 10 kA, the insulation coordination is carried out for an unrealistically low LIPL, because the LIPL should actually be specified for  $I_n = 20$  kA in this case, which according to the  $U-I$ -characteristic in Figure 2 would lead to a LIPL of 880 kV.

The nominal discharge current is therefore to be understood more as a *coordination* current in the context of insulation coordination than a technically justified rated current for the arrester. The actual function of this classification for the arrester is to specify different further demands and test requirements, depending on its class.

However, there are also technical aspects related to the choice of the nominal discharge current, for example when connecting arresters in parallel. If two arresters, working in parallel and having the same LIPL, but one is of  $I_n = 10$  kA and the other one of  $I_n = 20$  kA, both arresters will have different  $U-I$ -characteristics as shown in Figure 22, which shows the  $U-I$ -characteristic of the SM arrester from Figure 2 together with that of a typical SH arrester with the same LIPL. The arrester with the higher  $I_n$  value has the lower  $U-I$ -characteristic and will, therefore, take a greater part of the current in the event of a lightning overvoltage surge and will be subject to higher energetic stress than its neighbor with the lower  $I_n$  value.

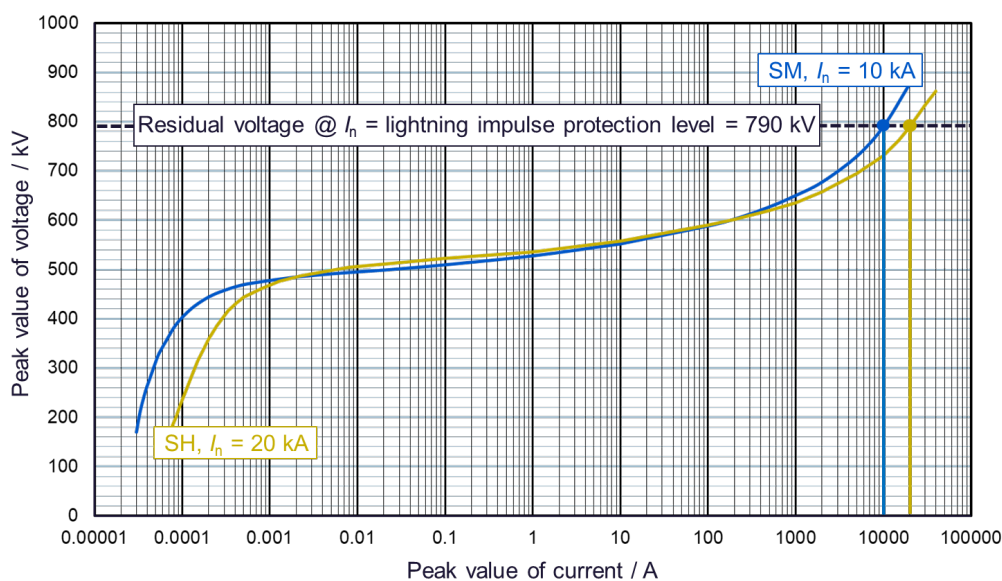

Figure 22:  $U-I$ -characteristics of two arresters of the same LIPL but different  $I_n$

For high-voltage *transmission* system arresters only two nominal discharge currents, 10 kA and 20 kA, are appropriate. In earlier editions of the arrester standards also the use of 5 kA arresters was considered possible in power systems of system voltages up to 170 kV. However, this approach has been abandoned in the current standards.

For central European *distribution* systems, 5 kA arresters are completely adequate. Only in exceptional cases (e.g., because of an above average *keranic level*) is the use of 10 kA arresters recommended. In practice the 10 kA arrester is becoming ever more common, as the price difference between the two types diminishes, while at the same time there are logistic advantages to using only one arrester type for the entire system.

## Selecting charge transfer rating $Q_{rs}$ , thermal energy rating $W_{th}$ and thermal charge rating $Q_{th}$

As already explained, the energy handling capability is differentiated according to the *impulse* and the *thermal* energy handling capability. The impulse energy handling capability is defined by the [repetitive charge transfer rating](#)  $Q_{rs}$ , the thermal energy handling capability by the [thermal energy rating](#)  $W_{th}$  for station arresters and the [thermal charge transfer rating](#)  $Q_{th}$  for distribution arresters. When specifying an arrester, it is imperative that both kinds of energy handling capability are specified, i.e. these are not alternative options. With leaving the concept of the [line discharge classes](#) and the transition to impulse and thermal energy handling capability in the standards, it was assumed that users today increasingly have a clear idea of the required levels. This is certainly the case in [EHV](#) and [UHV](#) systems. Almost always, or at least very often, users carry out transient network analyses, e.g. with the help of software such as EMTP. In this way, the charge transferred by the arrester to ground or the energy absorbed can be determined very easily for certain situations in the network. When determining the charge value for specifying  $Q_{rs}$ , it should be noted that the flowing charge during an event must not be integrated with the correct sign (then the result could even be a value close to zero), but the *absolute value* of the charge has to be used. For “standard” applications and especially for the lower high-voltage levels (sub transmission systems), the effort of system analyses is often not made. In this case, one is either dependent on estimates of the stresses to be expected, or one relies on operational experience. This can be a problem because arresters have so far been designed according to line discharge classes, while there are still no empirical values for dimensioning according to  $Q_{rs}$  and  $W_{th}$ . For this purpose, an “Appendix L” has been added to IEC 60099-4 Ed. 3.0, which both explains the old line discharge class concept and provides guidance on converting the former line discharge classes into sets of  $Q_{rs}$  and  $W_{th}$ . Therefore, it is started with this approach here as well.

In the arrester application guide IEC 60099-5, recommendations were given as to which line discharge classes should be used in which system voltage level. This table is reproduced in Appendix 1 ([Table 11](#)). If these line discharge classes or those of the arresters that have successfully been used in the network so far shall be used the following conversion table from IEC 60099-4 Ed. 3 Annex L, which is reproduced here in abbreviated form, will help ([Table 2](#)):

**Table 2:** Standard conversion from former LD classes to actual  $Q_{rs}$  and  $W_{th}$  values (for  $U_{res}/U_r = 1.8$ )

Former LD class	$Q_{rs}$ (C)	$W_{th}$ (kJ/kV)
1	0.5	2
2	1	4
3	1.6	7
4	2.4	10
5	3.6	14

According to the explanations in Appendix 1 of this guide, the energy conversion during a line discharge depends on the ratio  $U_{res}/U_r$ , i.e. the residual voltage when a switching impulse current flows to the rated voltage. Of course, these physical relationships also apply in the new classification system, so it is important to note that this conversion table is only valid for a ratio of  $U_{res}/U_r = 1.8$ , which means for a very low protection level of the arrester. If the arresters in the system were defined with higher protection levels and higher values of  $U_{res}/U_r$ , respectively, the table values must be corrected accordingly. Annex L of IEC 60099-4 Ed. 3.0 demonstrates this using five different calculation examples, the study of which is expressly recommended here.

Combining the information given in [Table 1](#), [Table 2](#) and [Table 11](#) it can be further concluded that the following arresters can be selected for standard applications in the relevant systems ([Table 3](#)):

**Table 3:** Recommended arresters for “standard” applications

System voltage $U_s$ (kV)	Arrester class	$Q_{rs}$ (C)	$W_{th}$ (kJ/kV)
$\leq 300$	SL	1	4
$\leq 420$	SM	1.6	7
$\leq 550$	SH	2.4	10
$\leq 800$	SH	3.6	14

A more precise way of determining  $Q_{rs}$  and  $W_{th}$  is, of course, determining the required values with the help of calculations or transient network analyses. These result directly in the arrester values to be specified. However, the standard only allows for rated values in certain steps, so that  $Q_{rs}$  and  $W_{th}$  are the next higher of the calculated values from the following list (**Table 4**) of permitted values (according to IEC 60099-4 Ed. 3.0):

**Table 4:** Steps of rated  $Q_{rs}$  and  $W_{th}$  values according to IEC 60099-4 Ed. 3.0

$Q_{rs}$	$W_{th}$
from 0.1 C to 1.2 C in steps of 0.1 C	from 1 kJ/kV to 5 kJ/kV in steps of 0.5 kJ/kV
from 1.2 C to 4.4 C in steps of 0.4 C	from 5 kJ/kV to 16 kJ/kV in steps of 1 kJ/kV
from 4.4 C up to 10.0 C in steps of 0.8 C	from 16 kJ/kV to 30 kJ/kV in steps of 2 kJ/kV
from 10 C to 20 C in steps of 2 C	from 30 kJ/kV up in steps of 6 kJ/kV
from 20 C upward in steps of 4 C	

For distribution arresters only the  $Q_{th}$  values from [Table 1](#) shall be used.

When deciding on a definite repetitive charge transfer rating  $Q_{rs}$  the required MO resistor diameter has also almost automatically been selected. **Table 5** is a rough orientation, whereby these relationships in detail depend on the particular make and manufacturer.

**Table 5:** Typical assignment of MO resistor diameter to repetitive charge transfer rating  $Q_{rs}$ 

MO resistor diameter in mm	$Q_{rs}$ in C
40	1.2
50	1.2 ... 1.6
60	2 ... 2.4
70	2.5 ... 3.2
80	3.2 ... 3.6
100	4 ... 6

In order to complete the considerations on the energy handling, a small example should be shown that proves that the repetitive charge transfer rating  $Q_{rs}$  and the thermal energy rating  $W_{th}$  have always to be considered together. For this purpose, the arrester whose  $U$ - $I$ -characteristic is shown in [Figure 2](#) is considered. This arrester is a class SM arrester with  $U_r = 336$  kV. It is further assumed to have a  $Q_{rs} = 2.0$  C (i.e. a higher value than the minimum required value according to [Table 1](#)) and a  $W_{th} = 7$  kJ/kV. Suppose the charge of 2.0 C is transferred in one single event by a switching current impulse with an amplitude of 1 kA. At this current, the arrester has a residual voltage of 650 kV (its switching impulse protection level in the  $U$ - $I$ -characteristic). In order to estimate the converted energy, the charge can now be multiplied by the residual voltage, i.e.  $W = 2.0 \text{ C} \cdot 650 \text{ kV} = 1.3 \text{ MJ}$ . The thermal energy handling capability, on the other hand, is  $W = 7 \text{ kJ/kV} \cdot 336 \text{ kV} = 2.35 \text{ MJ}$ . This shows that the arrester remains thermally stable after a single charge transfer of magnitude  $Q_{rs}$ . According to the definition of  $Q_{rs}$  in the standard, the arrester should again be able to transfer a charge of 2.0 C after 60 seconds, a time, however, after which the arrester has not cooled at all. This means that the arrester converts an energy of  $2 \cdot 1.3 \text{ MJ} = 2.6 \text{ MJ}$  within one minute. This would make it thermally unstable, since this value is greater than the permissible thermal energy  $W_{th}$ . In practice, this means that the charge  $Q_{rs}$  can theoretically be introduced several times in succession at intervals of one minute, but at the same time it has to be ensured that the thermal stability limit is not exceeded. Multiple stresses with  $Q_{rs}$  are therefore typically only permissible if the arrester remains disconnected from the network for at least one to two hours (cooling time constants for high-voltage arresters are in the range of 30 to 90 minutes) immediately after the stress. Conversely, the allowable rated thermal energy  $W_{th}$  must not be introduced in only one single event, as this stress would exceed the permissible  $Q_{rs}$  value. The rated thermal energy can therefore only be introduced in the form of two or more events, each of which does not violate the  $Q_{rs}$  limit.

After determining the rated voltage and subsequently choosing the MO resistor diameter, the protective characteristic of the arrester has been completely established. All residual voltage values result from the  $U$ - $I$ -characteristic of the selected type of MO resistor. The next step is to check whether the retained protective characteristic is adequate.

## Selection and review of the protection levels

The protective characteristic of an arrester is most frequently assessed by means of its lightning impulse protection level. That means it is assessed according to its residual voltage while the nominal discharge current is flowing. As already mentioned, according to the application guide of insulation coordination, IEC 60071-2, there must be a factor – the so-called [safety factor](#),  $K_s$  – of at least 1.15 between the [standard rated lightning impulse withstand voltage](#) of the device to be protected with a non-self-restoring insulation, and the highest lightning overvoltage which is expected to occur at its terminals. In this case it should be noted that, due to traveling wave processes and inductive voltage drops, the voltage at the terminals of the device to be protected will generally be higher than the voltage directly at the arrester terminals. Besides that, it should also be noted that – though very unlikely in high-voltage transmission systems – the discharge current may be higher than the nominal discharge current of the arrester.

If the distance between the arrester and the device is not too great – arresters have a [protective zone](#) of only a few meters in a distribution system and up to about sixty meters in high- and extra-high-voltage systems – this normally means that a [lightning impulse protection level](#) (LIPL) equal to the standard rated lightning impulse withstand voltage of the device to be protected, divided by a factor of 1.4, is adequate in protecting against lightning overvoltages<sup>1</sup>. It should, however, be kept in mind that this

<sup>1</sup> This factor 1.4 is obviously of a deterministic nature and therefore only serves as an estimate. In the course of insulation coordination, however, statistical methods are actually used. The representative fast front overvoltage  $U_{rp,iffo}$  when arresters are used is made up of the LIPL of the arrester plus a summand which is a factor to take into account the corona damping characteristics of the connected line, the number of parallel lines connected, the distance between the arrester

simplification might not be adequate for special system configurations and cases of application, or when the distance between the arrester and the device is great. Thus, the correct and standard procedure is to determine the expected overvoltages through calculations and to establish the necessary protection level of the arrester by means of insulation coordination studies. Information and instructions for this are found in the IEC publications 60071-1 and 60071-2, and recommendations for the application of surge arresters are made in IEC 60099-5.

It is common to cite the lightning impulse residual voltage also for the double value of the nominal discharge current. The corresponding values are normally between 5% and 15% above the lightning impulse protection level (see also [Figure 2](#)).

In the extra and ultra high voltage systems the [switching impulse protection level](#) (SIPL) is normally the determining value of an arrester's protective characteristic. It is generally cited, in accordance with IEC 60099-4, for fixed [switching current impulse](#) values (the [switching impulse discharge currents](#), see also the arrester classification in [Table 1](#)), which are listed in [Table 6](#).

**Table 6:** Switching impulse discharge currents for the definition of the SIPL

Arrester class	Switching impulse discharge current in kA
SH ( $I_n = 20$ kA)	2
SM ( $I_n = 10$ kA)	1
SL ( $I_n = 10$ kA)	0.5

The switching impulse residual voltage is typically between 75% and 90% of the 10 kA lightning current impulse residual voltage, depending each time on the MO resistor in use and the actual switching current impulse value. In the case of a 1 kA switching impulse discharge current, one can take (80...85)% of the 10 kA lightning current impulse residual value as a guideline<sup>1</sup> (see also [Figure 2](#), where a value of 82% can be found).

Just as with the lightning impulse protection level, the switching impulse protection level is to be selected on the basis that the switching overvoltage on the device to be protected is not higher than its [standard rated switching impulse withstand voltage](#) (SIWV)<sup>2</sup> divided by the safety factor  $K_s$  ( $K_s = 1.15$  in the case of non-self-restoring insulation). As a result of the comparatively slow process, voltage increases induced by traveling wave effects or inductive voltage drops, need not be considered. That means that the switching impulse protection level does not need to be lower than the standard rated switching impulse withstand voltage of the device, divided by a factor of 1.15.

In a few special applications, it is necessary to know the [steep current impulse protection level](#). Thus, it is also typically mentioned in the data sheet of the arrester. The residual voltage of MO resistors is about 5% (in extreme cases 10%) higher for steep current impulses compared with lightning current impulses of the same value. However, the published data of the steep current impulse protection level should be interpreted carefully. Basically the residual voltage during steep current rises (front times in

---

and the device to be protected, the span length of the connected line and in particular the frequency of direct lightning strikes to the overhead line conductor and the generally accepted failure rate. The outcome is then of a purely statistical nature. The determination of  $U_{p,ffo}$  is correspondingly time-consuming and is described in detail in IEC 60071-2 Ed. 5, Appendix E.

<sup>1</sup> Manufacturer-dependent deviations are possible.

<sup>2</sup> In this context SIL – the basic switching impulse insulation level – is frequently mentioned. This term, found in the IEEE standards, is, however, not defined in the IEC standards (see explanation of [SIL](#) in the appendix).

the range of  $\leq 1 \mu\text{s}$ ) is influenced by two different effects which nevertheless always occur together. One of these is the fact that the temporal behavior of the MO material during the transition from the non-conducting to a conducting state presents itself, when seen only externally, as inductive behavior (the residual voltage peak value lies temporally ahead of the peak value of the current, see [Figure 4](#)). Another is that of the inductivity of the geometrical arrangement having an effect of ca.  $1 \mu\text{H}$  per meter on the overall height. The latter influence can increase the residual voltage by an additional 5%, or even more. The IEC standard 60099-4 very precisely specifies how these two effects are to be separated, and that both must be included in the specified steep current impulse protection level. Not all manufacturers adhere to these requirements, so if there are any doubts, inquiries should be made.

If, when checking the protection levels of all the cited current impulse stresses, the requirements are fulfilled, then the choice of the electrical characteristic of the arrester is finished at this point. This is the case in the vast majority of standard applications. What, however, should be done, if any of these values are too high? For a given type of MO resistor all the residual voltage values, as well as the continuous operating and rated voltage, comprise a fixed ratio. Thus, none of these values can be decreased alone. Instead the whole characteristic would have to be shifted downwards, in order, for example, to obtain a lower lightning impulse protection level. This, however, is not allowed, as the continuous operating and rated voltage would also automatically become lower by the same percentage, and a stable continuous operation could no longer be guaranteed. In this case there is normally only one single permissible means: MO resistors with larger cross sections must be selected. This can be achieved by choosing a larger diameter or by connecting several resistors in parallel. Generally it is the case that the ratio of the lightning impulse protection level to the rated voltage is smaller, the bigger the MO resistor cross section is. This is easily illustrated using an *E-J-characteristic* instead of a *U-I-characteristic*<sup>1</sup> in [Figure 23](#), which is derived from [Figure 2](#). The associated arrester is assumed to use 58 mm diameter MO resistors. A diameter of 58 mm corresponds to a cross-sectional area of  $26.4 \text{ cm}^2$ , so the current density is  $J \approx 378 \text{ A/cm}^2$  with a surge current of 10 kA. If the resistor

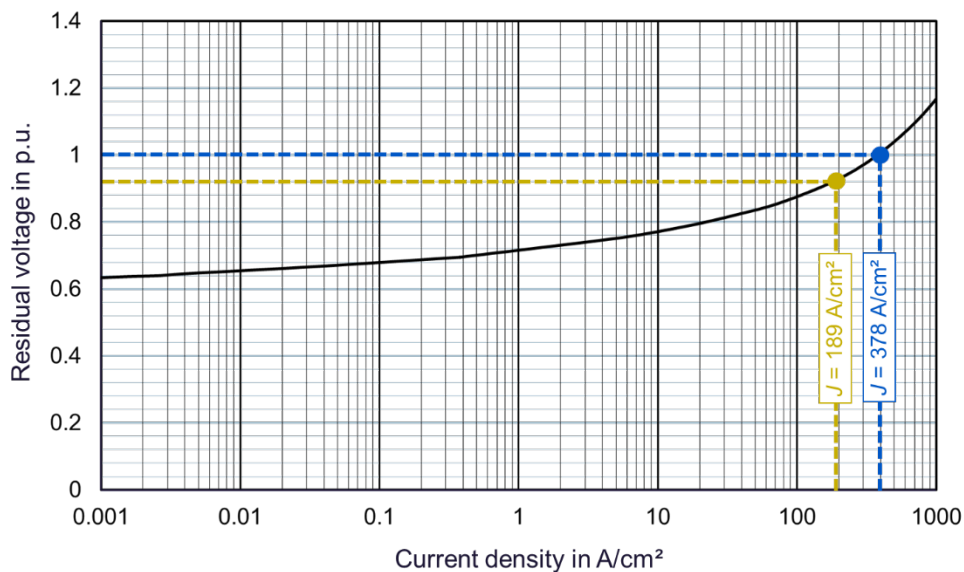

**Figure 23:** *E-J-characteristic* derived from the *U-I-characteristic* of [Figure 2](#)

diameter is increased to 80 mm or if two 58 mm resistors are used in parallel, which results in approximately the same cross-sectional area, the current density is halved to a value of  $J \approx 189 \text{ A/cm}^2$  at the same surge current. The *E-J-characteristic* shows that the voltage per unit height (the “field strength”) is now reduced from 1 p.u. to a value of only 0.92 p.u. For the same injected current, the larger cross section results in a lower current density and thus in lower residual voltages. Therefore, for

<sup>1</sup> In fact, it is a plot of voltage per unit height versus current density. This characteristic is a geometry-independent material characteristic of the MO material. By multiplying the voltage per unit height by the actual height of the MO column and the current density by the actual cross section of the MO resistors, a *U-I-characteristic* is obtained for each arrester.

a given continuous operating and rated voltage, respectively, a larger resistor cross section will always result in a lower protection level.

These relationships can also be made clear directly via the  $U-I$ -characteristic of [Figure 2](#). Doubling the cross-sectional area for a given surge current has the same effect as halving the surge current for the same cross-sectional area. The value of 0.92 p.u. can, therefore, be found in the characteristic for a surge current of 5 kA, resulting in a residual voltage of just under 730 kV.

The ratio of the residual voltage at a lightning current impulse of 10 kA, to the r.m.s. value of the rated voltage, is between over three in distribution arresters with small MO resistors almost down to two for heavy multi-column high-voltage arresters<sup>1</sup>. Requirements for low residual voltage values are thus frequently the reason that larger resistors and greater numbers of them, respectively, are used, than would actually be needed for the required energy handling capability. Therefore, lower residual voltage values should only be requested when they are absolutely necessary for the application in question.

## Selecting the housing

Dielectric and mechanical requirements are generally taken into account when selecting the housing. The length, the creepage distance, the shed profile, the diameter and the material must all be determined. The arrester characteristics determined by the housing are the [rated short-circuit current](#)  $I_s$ , the [specified long-term load](#), SLL, and the [specified short-term load](#), SSL.

The minimal housing length first of all obviously results from the demand that the MO resistor column (the active part) must fit. The length of this column is determined by the electrical data, which was gathered during the selection steps taken up to that point. Normally, however, this is not the dimensioning requirement. Generally further demands cause the housing lengths to be much greater than those of the active parts.

First of all, the [flashover or arcing distances](#), which result from the withstand voltage requirements, must be determined. According to IEC 60099-4 the arrester housing must fulfill the test requirements listed in **Table 7**.

---

<sup>1</sup> The individual factors are naturally very manufacturer-dependent. However, they are established within this range.

**Table 7:** Required withstand voltages of arrester housings according to IEC 60099-4 Ed. 3.0

	Station class arresters		Distribution class arresters
	for $U_s > 245$ kV	for $U_s \leq 245$ kV	
Lightning impulse withstand voltage, LIWV		1.3 · LIPL	
Switching impulse withstand voltage, SIWV	The lower value of: a) $1.1 \cdot e^{m \cdot 1000/8150} \cdot \text{SIPL}$ with - for $U_s \leq 800$ kV: $m = 1$ - for $U_s > 800$ kV: $m$ according to IEC 60071-2 Ed. 5.0, Figure 10, phase-to-earth insulation, with the value on the abscissa being $1.1 \cdot \text{SIPL}^1$ or b) the switching impulse withstand value of the equipment to be protected		
Power-frequency withstand voltage ( $\hat{u}$ ; duration 1 min), ACWV	–	1.06 · SIPL	0.88 · LIPL

In this Table the factor 1.3 of the lightning impulse withstand voltage is obtained from  $1.15 \cdot e^{1000/8150}$ , which reflects a 15% coordination factor to take into account discharge currents higher than  $I_n$  and the statistical nature of the withstand voltage of the insulation, and a 13% margin ( $e^{1000/8150} = 1.13$ ) to account for erection in altitudes up to 1 000 m. The factor  $1.1 \cdot e^{m \cdot 1000/8150}$  of the switching impulse withstand voltage reflects a 10% coordination factor to take into account discharge currents higher than the switching impulse discharge current of [Table 1](#) and the statistical nature of the withstand voltage of the insulation, and a variable, voltage-dependent margin to account for erection in altitudes up to 1 000 m. The complicated wording of the requirements for the test with switching impulse voltage for systems of  $U_s > 800$  kV takes into account the problem that, with increasing system voltage, it becomes more and more difficult for an arrester not to produce flashovers from its grading rings to neighboring flanges of its housing or to ground under the stress of its own switching impulse residual voltage.

Test voltages resulting from these requirements are typically well below those of the other devices of the system, as the following example of the lightning impulse withstand voltage shows: a typical arrester in a 420 kV system has a lightning impulse protection level of 790 kV (see [Figure 2](#)). Its housing must, therefore, be tested with a lightning impulse voltage of  $1.3 \cdot 790 \text{ kV} = 1\,027 \text{ kV}$ , which only comprises 72% of the standard lightning impulse withstand voltage of 1 425 kV, as it is normally applied in this system. This is clearly justified because the arrester housing is the best-protected insulation within the system. No higher voltages occur here other than the voltage drop directly across the enclosed MO resistors. At the same time the factors cited in the table already take different atmospheric conditions into account – such as installation at heights of up to 1 000 m – as well as the possibility of having arrester currents higher than the nominal discharge current. Nevertheless the same withstand

<sup>1</sup> Explanations of this approach and an adapted representation of the figure mentioned can be found in Appendix 2, term “[exponent m](#)”.

voltage values are unfortunately frequently requested for the arrester housings as those of the rest of the devices, which consequently leads to unnecessarily long housings. The result is then uneconomical and at the same time technically disadvantageous arrester housings<sup>1</sup>.

For the required flashover distances  $s$  and thus for the minimum length of the complete housing or its individual units, the minimum clearance from the grading ring to ground, or the minimum distances from the grading ring to the metal flanges of the individual units (see also [flashover distance](#) in Appendix 2), 500 kV/m for lightning impulse voltage and  $1\,069 \text{ kV/m} \cdot \ln(0.46 \cdot s + 1)$  for switching impulse voltage can be assumed as specific withstand voltages. The minimum required housing lengths and clearances can then be estimated as the higher of the two values  $s = u/500$  (for lightning impulse voltage) and  $s = 2.2 \cdot (e^{u/1069} - 1)$  (for switching impulse voltage), where for the voltage  $u$ , depending on the clearance considered, the full withstand voltage (LIWV, SIWV) or fractions thereof must be used.<sup>2</sup>

If the site altitude is over 1 000 m – which according to the corresponding IEC definition no longer counts as a “normal service condition”<sup>3</sup> – then greater clearances and housing lengths must be chosen in order to maintain the required withstand voltage values in conditions of lower air density. Refer to IEC 60071-2 for a correct altitude correction in this case.

A much more frequent reason for longer housings is, however, creepage distance requirements. The shortest possible housing as a result of the length of the active part can normally be achieved only by designing for [pollution levels](#) of “a”, “b” or “c”<sup>4</sup>, i.e., for [unified specific creepage distances](#) of up to 34.6 mm/kV or [specific creepage distances](#) of up to 20 mm/kV<sup>5</sup>. For central European requirements this is often adequate. Worldwide, however, levels “d” and “e” also play an important role. These lead to unified specific creepage distance requirements of 43.3 mm/kV and 53.7 mm/kV (corresponding to specific creepage distances of 25 mm/kV and 31 mm/kV). In addition, there are locations which make the use of even longer creepage distances necessary, for example those with maritime desert climates, or in some cases, these conditions in combination with industrial pollution. In such extreme conditions it should be noted, however, that there are often other, more appropriate means of improving the operational reliability than increasing the creepage distance. For example, one can select a higher continuous operating and rated voltage (naturally, with associated higher protection levels), or use MO resistors with greater diameters, or housings with greater distances between the active part and the housing wall (to reduce the capacitive coupling between external electrical discharges and the internal active part). At any rate one should keep in mind that “artificial” extensions of the active part (by inserting metal spacers), which have to be brought about by creepage distance extensions, can also have a negative effect on the rest of the operation behavior, as already mentioned in connection with withstand voltage requirements.

The different shed profiles and some of their characteristics were dealt with in the chapter on “Constructive Design of MO Arresters”. A general recommendation for a specific shed profile cannot be given here. When in doubt, in each case, one should be chosen which has proved to be effective in service at the particular site.

Arresters with polymer housing can theoretically make use of a “silicone bonus” if they use silicone rubber sheds. For example, the hydrophobic properties mean that the creepage distance could be reduced to 80% of the value required for a porcelain housing. However, this is not normally done in practice as the hydrophobic properties may be lost under certain operating conditions (e.g. constant

<sup>1</sup> Using longer housings can, for example, result in lower short-circuit strength or a disadvantageous voltage distribution along the arrester axis.

<sup>2</sup> Lengths and clearances in m and voltages in kV; see explanations in IEC 60099-4 Ed. 3.0, Section 8.2

<sup>3</sup> An explanation will be included later in this section.

<sup>4</sup> According to the definition in IEC 60815-1

<sup>5</sup> See Appendix 2 for an explanation of the differences in creepage distance definitions and pollution classes between the old IEC 60815, Ed. 1, 1986 and the current IEC 60815-1, -2, -3, published in 2008.

moisture over a long period) and the housing reverts to insulation characteristics that are comparable to a porcelain housing. Please refer to the explanations in IEC 60815-3.

After the housing parameters have thus far been determined in order to fulfill the electrical requirements, now in the next and last steps, the mechanical criteria follow. They indirectly lead to the selection of the housing material and the housing diameter. Often there is only a vague idea as to the mechanical stress of an arrester in service, and accordingly no requirements are made, or, maybe even worse, ones in which the values are too high. If there is no information available about the actual requirements, the following values can serve as a guideline for the necessary static head loads in high-voltage systems: 350 N for  $U_s = 72.5$  kV, 400 N for  $U_s = (123...420)$  kV, 600 N for  $U_s = 550$  kV and 800 N for  $U_s = 800$  kV. These values represent absolute minimal requirements assuming that the arrester is connected by strain relieving conductor loops and a wind velocity of 34 m/s ( $\approx 120$  km/h) is not exceeded, which according to IEC 60694 belongs to the "normal service conditions".

Besides the static head loads, which normally cause the arrester few problems, dynamic requirements must also be considered. These can, for example, occur as a result of short-circuit currents on the line, or of gusting winds. In this case arresters with porcelain housing can, because of the brittle properties and statistical behavior of the porcelain, be strained at only up to 40% of its dynamic strength. The specified permissible dynamic head loads should prove, on the other hand, to have at least a 20% safety margin to the actual mean breaking values, ascertained during tests<sup>1</sup>.

IEC has replaced the static head load with the term [specified long-term load](#) (SLL), and the dynamic head load with [specified short-term load](#) (SSL), and it has introduced the abbreviation MBL for the [mean breaking load](#). The head load values mentioned above can now be expanded upon accordingly in **Table 8** for arresters with porcelain housing:

**Table 8:** Recommended mechanical characteristics for arresters with porcelain housing

Highest system voltage $U_s$ / kV	SLL / N	SSL / N	MBL / N
< 123	350	875	$\geq 1050$
123 ... 420	400	1000	$\geq 1200$
550	600	1500	$\geq 1800$
800	800	2000	$\geq 2400$

The ratios look somewhat different for polymer-housed arresters. However, appropriate rules and standards have still not been established because of the many different designs and insufficient real-life experience. At any rate a smaller distance can clearly be adopted between the static and the dynamic loads, since the polymer housing (with the exception of the cast resin housing, which has brittle characteristics similar to those of porcelain, and thus, is considered in exactly the same manner) diverges less in its mechanical characteristics. According to current findings, a static strength utilization of at least 70% of the breaking value (whereby the breaking value is, at the same time, difficult to define and determine for a polymer housing) appears to be unquestionably permissible. Polymer housings, in contrast to porcelain housings, are visibly deflected under the influence of mechanical forces. Generally, this is not a consideration, however, in those cases in which this sort of behavior would cause problems, choosing a mechanically stronger housing must be considered, which will be less strained under the loads occurring here, and thus be less deflected<sup>2</sup>.

For polymer-housed arresters in distribution systems a dynamic strength (SSL) of 250 N can be considered sufficient, resulting in a static strength (SLL) of 175 N. While the values cited in Table 8

<sup>1</sup> Data in accordance with DIN 48113 and IEC 60099-4, Annex M

<sup>2</sup> See "[Mechanical loads](#)" in the appendix for more information.

indicate relatively minimal demands on the housing strength, these can escalate enormously when taking seismic requirements into account. Such requirements go beyond the “normal operation conditions”, and the associated demands must be explicitly described in an enquiry. There are various standardized calculation and test procedures which determine the behavior of an arrester under such conditions. Typically a completely assembled arrester is subjected to an earthquake test on a shaking table, on which at least two and preferably three axes are accelerated at the same time (**Figure 24**). The excitation may be carried out sinusoidal – temporary or transient – or occur at a spectrum of different frequencies and amplitudes, in order, as nearly as possible, to simulate a real earthquake (“time-history-test”). Extreme requirements can in many cases more easily be fulfilled with the use of polymer housings, especially with the “tube design”, than with porcelain housings.



**Figure 24:** Polymer housed arresters for system voltages of  $U_s=170$  kV,  $U_s=245$  kV and  $U_s=420$  kV during seismic testing on a shaking table

Taking seismic requirements into consideration is a common need for only a few locations worldwide. However, out of the previous list of mechanical characteristics, the short-circuit withstand capability must be considered in every case. It characterizes the failure mode of an arrester after the occurrence of an operational overload of the MO resistors. On very rare occasions an overload may occur, for example in a distribution system as a result of a [nearby direct lightning strike](#), due to the temporary overvoltages in the case of an intermittent earth fault in a system with isolated neutral, or – even less frequently – because of a power-frequency voltage transfer in a high-voltage system from one system with a higher to another with a lower voltage, caused by a damaged conductor or line galloping. After overloading, an arc develops inside of the arrester housing, through which the site-specific power-frequency short-circuit current flows. In an arrester with an enclosed gas volume, pressure then increases instantaneously within the inner-housing. Pressure relief devices, however, prevent the housing from exploding. Accordingly, the relevant test standards (IEC 60099-1, IEC 60099-4, IEEE C62.11) used to refer to the “pressure relief behavior” and to “pressure relief tests”. As the polymer insulated arresters in part no longer contain enclosed gas volumes in their housing, it makes sense to refer more generally to “short-circuit behavior”, and accordingly the associated tests are now called “[short-circuit tests](#)” in IEC 60099-4. No defined pressure builds up in this type of housing to activate a pressure relief device – instead, the resulting arc seeks a path through the housing wall to an arbitrary point or points that have been specially provided. The goal, however, always remains the same: in the case of an arrester overloading, according to the test requirements, the housing must either remain

intact, or if it breaks, the housing fragments and the ejected parts must fall to the ground within a circumference around the arrester, whose radius is about the same as the height of the arrester (this means a permissible angle of the parts of approximately 45°). Housing breakage that fulfills these requirements is expressly permissible. Under no circumstances, however, is a violent shattering of the housing allowed, whereby “violent shattering” is defined as occurring when fragments fall outside the area around the arrester in which the parts are required to remain<sup>1</sup>. Only parts up to a maximum 60 g in weight may be found outside the area<sup>2</sup>. The chance of a housing breakage must be considered when building a substation. Because of this risk it is generally advisable, for example, to avoid using an arrester as a post insulator for a conductor or a busbar. If this, however, is desired, polymer-housed arresters with the “tube design” might be used, whereby it should be noted that the required behavior cannot automatically be found in all designs.

The maximum short-circuit current, flowing for a period of 200 ms, is the [rated short-circuit current](#)  $I_s$ , given in kiloamperes. **Table 9** presents the standard rated short-circuit currents and the further testing requirements:

**Table 9:** Currents in the short-circuit test (from IEC 60099-4 Ed. 3.0)

Nominal discharge current $I_n$ / kA	SH Rated short-circuit current $I_s$ (duration 200 ms) /	Reduced short-circuit currents (duration 200 ms) / kA		Low short-circuit current (duration 1 s) / A
20 or 10	80	50	25	600 ± 200
20 or 10	63	25	12	600 ± 200
20 or 10	50	25	12	600 ± 200
20 or 10	40	25	12	600 ± 200
20 or 10	31.5	12	6	600 ± 200
20, 10 or 5	20	12	6	600 ± 200
10 or 5	16	6	3	600 ± 200
10, 5 or 2.5	10	6	3	600 ± 200
10, 5 or 2.5	5	3	1.5	600 ± 200
10, 5 or 2.5	2.5	-	-	600 ± 200
10, 5 or 2.5	1	-	-	Amplitude and time on agreement between user and manufacturer
10, 5 or 2.5	< 1	-	-	

The rated short-circuit current selected when the arrester is chosen should at least comply with the maximum short-circuit current expected at the location of the arrester. The testing standard requires that the test is carried out with the full rated short-circuit current such that the current is overlaid with a decaying DC component, to reach the peak value of 2.5 times the root-mean-square value (where  $I_s = 80$  kA, this means that a peak value of 200 kA must be reached in the test!<sup>3</sup>). This reproduces the worst

<sup>1</sup> Unless they have witnessed a failed short-circuit test, people are inclined to use the word “explosion” for an arrester that breaks apart when not even under pressure. In fact, a real, unsuccessful pressure relief can hurl large pieces of the arrester tens of meters away.

<sup>2</sup> After an otherwise successful short-circuit test, tiny pieces of the arrester are often found outside the area, propelled there purely by the pressure wave caused by the arc.

<sup>3</sup> An oscillogram of such current is shown in Appendix 2 under the keyword [short-circuit tests](#)

case of a short-circuit close to the generator. The table continues to list reduced short-circuit currents of around 50% and 25% of the rated short-circuit current that must also be tested. The reason is that it has occasionally been observed in practice that the arrester housing shatters at short-circuit currents below the specified maximum because the pressure relief devices were only optimized for the extreme case and reacted too sluggishly at lower currents. Finally, the test must also be carried out with a standard "low short-circuit current" of  $600\text{ A} \pm 200\text{ A}$ . This current flows for a duration of one second, and within this time period the pressure relief devices (if existing in the design) must have opened. This part of the test is carried out to prove that the pressure relief devices of the arrester can also open under very low fault current stress. For polymer-housed arresters it also demonstrates the arrester's resistance to fire.

It is important to note that the manufacturer must declare a short-circuit current rating for each family of arresters. Only for applications with expected short-circuit currents below 1 kA the rated value "zero" may be claimed. In this case, however, "0" must be indicated on the name plate. A test with rated or reduced short-circuit current is then not to be carried out, but in any case a low short-circuit current test with test conditions to be agreed upon.

For the high currents, short-circuit withstand capability is tested on the longest unit of a type. For arresters with porcelain housing it is influenced most of all by the following parameters:

- Housing diameter: greater diameters bring about higher strength
- Housing length: the greater the length, the lower the strength at a given diameter
- Wall thickness: strength increases with increasing wall thickness
- Housing material: the porcelain quality "C 130" results in greater strength than quality "C 120"

For the first two parameters the same contexts generally apply for polymer-housed arresters. There are, however, other design factors that have an effect, for example whether it is an arrester with an enclosed gas volume ("tube design") or not, and if not, whether it is a "cage design" or "wrapped design", and which particular version. This will not be discussed in further detail here. **Figures 25 to 27**



**Figure 25:** Polymer-housed arrester ("cage-design") after a short-circuit test at rated current (65 kA, 200 ms). The housing is ripped but in mechanically sound condition. Details of the test setup can well be seen. For further information see short-circuit tests in the appendix.

show the results of successfully completed short-circuit tests with the rated short-circuit (withstand) current, on two polymer-housed arrester types and one porcelain housed arrester.

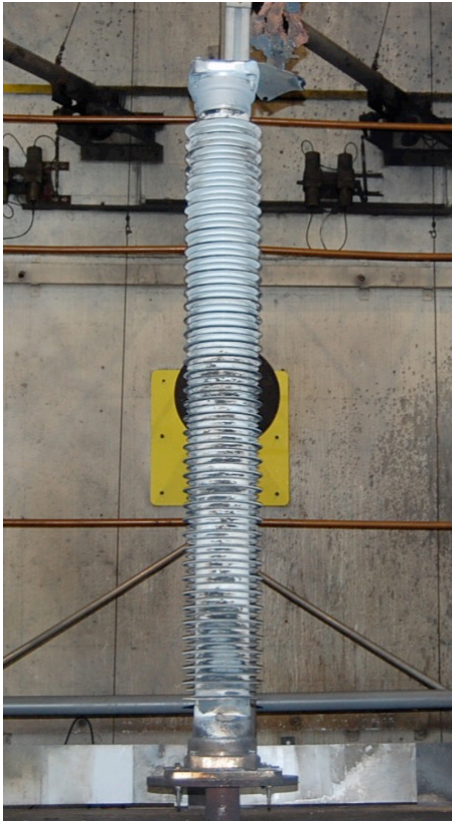

**Figure 26:** Polymer-housed arrester (“tube design”) after a test at rated short-circuit current (80 kA, 200 ms). The housing has remained completely intact.



**Figure 27:** Porcelain-housed arrester after a test at rated short-circuit current (63 kA, 200 ms). Apart from a few broken sheds, the housing has remained intact.

At this point the selection of an arrester is complete. Altogether the mechanical requirements – that is, the required head loads, the seismic demands and the short-circuit withstand capability – determine the appropriate combination of housing material and type, diameter and length. At the same time the length of a porcelain housing is restricted to a size of about two meters for technical and manufacturing reasons. For polymer-housed arresters – at least for certain designs – greater lengths are possible and common. If the required total length of an arrester is greater than is possible to enclose in a single housing, then the arrester is made up of several units. It is, however, not only a question of cost – several units means that multiple flanges, sealing systems, pressure relief devices, etc. exist – it is also advantageous to use single unit arresters if they are operated in a heavily polluted environment<sup>1</sup>. At present this is possible for arresters with porcelain housings with a highest system voltage of up to 245 kV and for certain designs of polymer-housed arresters at a level of up to 300 kV.

## Service conditions

“Normal service conditions” have been mentioned a few times already. Normally all the characteristic values are only determined for normal service conditions by the manufacturer. Thus, during the

<sup>1</sup> With multi-unit arresters under certain conditions, it is theoretically possible for pollution-related currents flowing on the housing surface at the intermediate flanges to commutate into the active parts of the adjacent units and heat up the active parts there.

selection of an arrester, it is necessary to check whether these conditions apply to the planned installation. The following is a list of normal service conditions<sup>1</sup> found in standard IEC 60099-4, 5.4.1:

- Ambient air temperature within the range of - 40° C to + 40° C
- Solar radiation 1.1 kW/m<sup>2</sup>
- Altitude not exceeding 1000 m above sea level
- Frequency of the a.c. power supply not less than 48 Hz and not exceeding 62 Hz
- Power-frequency voltage applied continuously between the terminals of the arrester not exceeding the arrester's continuous operating voltage
- Wind velocity  $\leq 34$  m/s
- Vertical mounting of the arrester

## Examples

The description of the configuration and selection procedure is now concluded, and some explanatory numerical examples<sup>2</sup> are provided below. To begin with, they refer to the most common application of arresters between phases and the earth ("phase arresters"), and are to be understood as standard layouts, as they would have been intended by a manufacturer if no further requirements and information, respectively, are submitted with an arrester enquiry other than that of the system voltage and the type of neutral earthing of the system. At the same time, this represents the minimally required information, without which an arrester cannot be reasonably laid out. Of course, the resulting arrester may only fulfill the absolute minimum requirements of the system. The characteristic values determined on the basis of so little input data should be carefully checked so that none of the actual system requirements are overlooked. The more precisely the information and requirements are specified, the more likely the resulting arrester will fulfill all the demands of the application in question. In special cases a system or insulation coordination study can prove the effectiveness of an arrester layout and the associated achievable protection of the equipment against lightning and switching overvoltage.

In the end the electrical configuration of arresters to protect the neutral point of the transformer ("neutral point arresters") is briefly described.

The numerical examples represent functioning minimal configurations. However, they are not necessarily typical or common layouts. Instead for good reasons, normally more safety would be provided for. By choosing the continuous operating and the rated voltage higher than is minimally required, it is possible to increase the operational reliability considerably, while in most cases the corresponding increase in the protection level can be tolerated. But the opposite is often the case in isolated or resonant earthed neutral systems, in which the continuous operating voltage of the arresters must be very high due to the high temporary overvoltages that occur and as a result the minimum achievable protection level is often so high that it cannot be further increased. Some national versions of the application guide IEC 60099-5 – for instance the German – have typical arrester configurations included in their Informative Annex B, from which the most common values for continuous operating and rated voltages and the protection levels for the individual system voltage levels can be obtained.

---

<sup>1</sup> Examples for "abnormal service conditions" are included in Annex A of IEC 60099-4. Also Annex D continues to provide information on enquiries and tenders.

<sup>2</sup> The resulting characteristic values are to be regarded as reference values; details are naturally manufacturer-specific.

### Example 1: "Solidly earthed neutral 72.5 kV system"

(All the information which is asterisked (\*) are typical. Individually, however, these are manufacturer-dependent values.)

**Tacitly assumed, if no further information is given and no special requests are made:**

- $U_s$ : 72.5 kV ( $U_n$ : 55 kV...66 kV)
- lightning impulse withstand voltage of equipment, LIWV<sub>e</sub>: 325 kV
- earth fault factor,  $k$ : 1.4
- maximum duration of temporary overvoltage: 10 s
- required nominal discharge current,  $I_n$ : 10 kA
- required former line discharge class: 1
- required designation: SL
- required repetitive charge transfer rating,  $Q_{rs}$ : 1.0 C
- required rated thermal energy,  $W_{th}$ : 4 kJ/kV
- pollution level: b ("light")
- maximum short-circuit current,  $I_s$ : 20 kA

**Determining the minimally required continuous operating and rated voltage:**

- $U_{c, \min} = 1.05 \cdot U_s / \sqrt{3} = 1.05 \cdot 72.5 / \sqrt{3} \text{ kV} = 44 \text{ kV}$
- $U_{rl, \min} = 1.25^* \cdot U_{c, \min} = 1.25^* \cdot 44 \text{ kV} = 55 \text{ kV}$
- $U_{r2, \min} = 1.4 \cdot (U_s / \sqrt{3}) / k_{\text{tov}, 10 \text{ s}} = 1.4 \cdot (72.5 / \sqrt{3}) / 1 = 59 \text{ kV}$

**Establishing the actual continuous operating and rated voltage:**

- $U_r = U_{r2, \min}$ , rounded up to the next value divisible by 3 = 60 kV. Normally an arrester with a rated voltage of at least 60 kV is used in this system. This leads to a more stable layout, and nevertheless offers a sufficiently low protection level.
- $U_r = 60 \text{ kV}$
- $U_c = U_r / 1.25^* = 60 \text{ kV} / 1.25^* = 48 \text{ kV}$

**Selecting an MO resistor suitable for  $I_n = 10 \text{ kA}$ , the required repetitive charge transfer rate and rated thermal energy:**

- repetitive charge transfer rating,  $Q_{rs}$ : 1.2 C
- rated thermal energy,  $W_{th}$ : 5 kJ/kV
- MO diameter: 48\* mm
- $\hat{u}_{10 \text{ kA}} / U_r = 2.55^*$

**Height of the MO resistor column:**

- $h_{MO} \approx 400^* \text{ mm}$

**The resulting protective characteristics\*:**

- lightning impulse protection level, LIPL ( $\hat{u}_{10 \text{ kA}, 8/20 \mu\text{s}}$ ): 153 kV
- switching impulse protection level, SIPL ( $\hat{u}_{0.5 \text{ kA}, 30/60 \mu\text{s}}$ ): 118 kV

**Checking the protective values:**

- $LIWV_e/LIPL = 325 \text{ kV}/153 \text{ kV} = 2.12 \rightarrow$  definitely sufficient

**Selecting a housing:**

Minimal requirements:

- lightning impulse withstand voltage of the housing,  $LIWV_h = 1.3 \cdot LIPL = 1.3 \cdot 153 \text{ kV} = 199 \text{ kV}$   
with specific flashover distance  $\approx 500 \text{ kV/m} \rightarrow s \approx 400 \text{ mm}$   
 $\rightarrow h_{\text{min, arrester}} = s + 2 \cdot h_{\text{flange}}$
- power-frequency withstand voltage 1 min, wet, of the housing,  $ACWV_h = 1.06/\sqrt{2} \cdot SIPL = 1.06/\sqrt{2} \cdot 118 \text{ kV} = 88 \text{ kV}$
- creepage distance:  $16 \text{ mm/kV} \cdot 72.5 \text{ kV}$  ( $27.7 \text{ mm/kV} \cdot 41.9 \text{ kV}$ ) = 1 160 mm
- permissible head load static (SLL): 350 N
- permissible head load dynamic (SSL): 875 N
- rated short-circuit current ( $I_s$ ): 20 kA
- typical housing height: 620 mm
- number of units: 1
- grading ring: no

## Example 2: “Resonant earthed neutral 123 kV system”

(All the information which is asterisked (\*) are typical. Individually, however, these are manufacturer-dependent values.)

**Tacitly assumed, if no further information is given and no special requests are made:**

- $U_s$ : 123 kV ( $U_n$ : 110 kV)
- lightning impulse withstand voltage of equipment, LIWV<sub>e</sub>: 550 kV
- operation under earth fault conditions for > 30 min.
- required nominal discharge current,  $I_n$ : 10 kA
- required former line discharge class: 2
- designation: SL
- required repetitive charge transfer rating,  $Q_{rs}$ : 1.0 C
- rated thermal energy,  $W_{th}$ : 4 kJ/kV
- pollution level: b (“light”)
- maximum short-circuit current,  $I_s$ : 40 kA

**Determining the minimally required continuous operating and rated voltage:**

- $U_{c, \min} = U_s = 123$  kV
- $U_{r, \min} = 1.25^* \cdot U_{c, \min} = 1.25^* \cdot 123$  kV = 154 kV
- (The rated voltage, however, has no technical significance in a resonant earthed system.)

**Establishing the actual continuous operating and rated voltage:**

- $U_r = U_{r, \min} = 154$  kV (exception from the 3 kV step rule in order to achieve a sufficiently low protection level)
- $U_c = U_r / 1.25^* = 154$  kV / 1.25<sup>\*</sup> = 123 kV<sup>1</sup>

**Selecting an MO resistor suitable for  $I_n = 10$  kA, the required repetitive charge transfer rate and rated thermal energy:**

- repetitive charge transfer rating,  $Q_{rs}$ : 2.0 C
- rated thermal energy,  $W_{th}$ : 5 kJ/kV
- MO diameter: 60<sup>\*</sup> mm, (selection of a larger diameter in order to achieve a sufficiently low protection level; diameter of 48 mm would theoretically be possible)
- $\hat{u}_{10 \text{ kA}} / U_r = 2.25^*$
- Depending on the actual TOV requirements higher ratios of  $\hat{u}_{10 \text{ kA}} / U_r$  might be needed to guarantee thermal stability.

**Height of the MO resistor column:**

- $h_{MO} \approx 940^*$  mm

**The resulting protective characteristics<sup>2</sup>:**

- lightning impulse protection level, LIPL ( $\hat{u}_{10 \text{ kA}, 8/20 \mu\text{s}}$ ): 347 kV<sup>2</sup>
- switching impulse protection level, SIPL ( $\hat{u}_{0.5 \text{ kA}, 30/160 \mu\text{s}}$ ): 278 kV

<sup>1</sup> Power-frequency voltage values are rounded down to whole numbers.

<sup>2</sup> Residual voltage values are mathematically rounded to whole numbers.

**Checking the protective values:**

- $LIWV_e/LIPL = 550 \text{ kV}/347 \text{ kV} = 1.59 \rightarrow$  generally sufficient

**Selecting a housing:**

Minimal requirements:

- lightning impulse withstand voltage of the housing,  $LIWV_h =$
- $1.3 \cdot LIPL = 1.3 \cdot 347 \text{ kV} = 451 \text{ kV}$
- with specific flashover distance  $\approx 500 \text{ kV/m} \rightarrow s \approx 902 \text{ mm}$
- $\rightarrow h_{\min, \text{arrester}} = s + 2 \cdot h_{\text{flange}}$
- power-frequency withstand voltage 1 min, wet, of the housing,  $ACWV_h =$
- $1.06/\sqrt{2} \cdot SIPL = 1.06/\sqrt{2} \cdot 278 \text{ kV} = 208 \text{ kV}$
- creepage distance:  $16 \text{ mm/kV} \cdot 123 \text{ kV}$  ( $27.7 \text{ mm/kV} \cdot 71 \text{ kV}$ )  $\approx 1970 \text{ mm}$
- permissible head load static (SLL): 400 N
- permissible head load dynamic (SSL): 1 000 N
- Typical housing height: 1 250 mm
- rated short-circuit current ( $I_s$ ): 40 kA
- number of units: 1
- grading ring: no

### Example 3: "Solidly earthed neutral 245 kV system"

(All the information which is asterisked (\*) are typical. Individually, however, these are manufacturer-dependent values.)

**Tacitly assumed, if no further information is given and no special requests are made:**

- $U_s$ : 245 kV ( $U_n$ : 220 kV)
- lightning impulse withstand voltage of equipment, LIWV<sub>e</sub>: 1 050 kV
- earth fault factor,  $k$ : 1.4
- maximum duration of temporary overvoltage: 10 s
- required nominal discharge current  $I_n$ : 10 kA
- required former line discharge class: 3
- designation: SM
- required repetitive charge transfer rating,  $Q_{rs}$ : 1.6 C
- rated thermal energy,  $W_{th}$ : 7 kJ/kV
- pollution level: b ("light")
- maximum short-circuit current,  $I_s$ : 50 kA

**Determining the minimally required continuous operating and rated voltage:**

- $U_{c, \min} = 1.05 \cdot U_s / \sqrt{3} = 1.05 \cdot 245 / \sqrt{3} \text{ kV} = 149 \text{ kV}$
- $U_{il, \min} = 1.25^* \cdot U_{c, \min} = 1.25^* \cdot 149 \text{ kV} = 187 \text{ kV}$
- $U_{r2, \min} = 1.4 \cdot (U_s / \sqrt{3}) / k_{\text{tov}, 10 \text{ s}} = 1.4 \cdot (245 / \sqrt{3}) \text{ kV} / 1 = 198 \text{ kV}$

**Establishing the actual continuous operating and rated voltage:**

- $U_r = U_{r2, \min}$  divisible by 3 = 198 kV
- Normally an arrester with a rated voltage of at least 198 kV is used in this system. This leads to a considerably more stable layout, and nevertheless offers a sufficiently low protection level.
- $U_r = 198 \text{ kV}$
- $U_c = U_r / 1.25^* = 198 \text{ kV} / 1.25^* = 158 \text{ kV}$

**Selecting an MO resistor suitable for  $I_n = 10 \text{ kA}$ , the required repetitive charge transfer rate and rated thermal energy:**

- repetitive charge transfer rating,  $Q_{rs}$ : 2.0 C
- rated thermal energy,  $W_{th}$ : 7 kJ/kV
- MO diameter: 60\* mm
- $\hat{u}_{10 \text{ kA}} / U_r = 2.4^*$  (This factor is characteristic for the MO resistor used when configuring it for the SM class. Compare with Example 2!)

**Height of the MO resistor column:**

- $h_{\text{MO}} \approx 1350^* \text{ mm}$

**The resulting protective characteristics\*:**

- lightning impulse protection level, LIPL ( $\hat{u}_{10 \text{ kA}, 8/20 \mu\text{s}}$ ): 475 kV
- switching impulse protection level, SIPL ( $\hat{u}_{1 \text{ kA}, 30/60 \mu\text{s}}$ ): 390 kV

**Checking the protective values:**

- $\text{LIWV}_e / \text{LIPL} = 1050 \text{ kV} / 475 \text{ kV} = 2.21 \rightarrow$  definitely sufficient

**Selecting a housing:**

Minimal requirements:

- lightning impulse withstand voltage of the housing,  $LIWV_h =$
- $1.3 \cdot LIPL = 1.3 \cdot 475 \text{ kV} = 618 \text{ kV}$
- with specific flashover distance  $\approx 500 \text{ kV/m} \rightarrow s \approx 1\,240 \text{ mm}$
- $\rightarrow h_{\text{min, arrester}} = s + 2 \cdot h_{\text{flange}}$
- power-frequency withstand voltage 1 min, wet, of the housing,  $ACWV_h =$
- $1.06/\sqrt{2} \cdot SIPL = 1.06/\sqrt{2} \cdot 390 \text{ kV} = 292 \text{ kV}$
- creepage distance:  $16 \text{ mm/kV} \cdot 245 \text{ kV}$  ( $27.7 \text{ mm/kV} \cdot 141.5 \text{ kV}$ ) =  $3\,920 \text{ mm}$
- permissible head load static (SLL):  $400 \text{ N}$
- permissible head load dynamic (SSL):  $1\,000 \text{ N}$
- rated short-circuit current ( $I_s$ ):  $50 \text{ kA}$
- typical housing height:  $1\,760 \text{ mm}$
- number of units:  $1^*$  (borderline case)
- grading ring<sup>†</sup>: no (borderline case)

### Example 4: "Solidly earthed neutral 420 kV system"

(All the information which is asterisked (\*) are typical. Individually, however, these are manufacturer-dependent values.)

**Tacitly assumed, if no further information is given and no special requests are made:**

- $U_s$ : 420 kV ( $U_n$ : 380 kV)
- lightning impulse withstand voltage of equipment, LIWV<sub>e</sub>: 1 425 kV
- earth fault factor,  $k$ : 1.4
- maximum duration of temporary overvoltage: 10 s
- required nominal discharge current,  $I_n$ : 10 kA
- required former line discharge class: 3
- designation: SM
- required repetitive charge transfer rating,  $Q_{rs}$ : 1.6 C
- rated thermal energy,  $W_{th}$ : 7 kJ/kV
- pollution level: d ("heavy")
- maximum short-circuit current,  $I_s$ : 50 kA

**Determining the minimally required continuous operating and rated voltage:**

- $U_{c, \min} = 1.05 \cdot U_s / \sqrt{3} = 1.05 \cdot 420 / \sqrt{3} \text{ kV} = 255 \text{ kV}$
- $U_{il, \min} = 1.25^* \cdot U_{c, \min} = 1.25^* \cdot 255 \text{ kV} = 319 \text{ kV}$
- $U_{i2, \min} = 1.4 \cdot (U_s / \sqrt{3}) / k_{\text{tov}, 10 \text{ s}} = 1.4 \cdot (420 / \sqrt{3}) / 1.0^* \text{ kV} = 339 \text{ kV}$

**Establishing the actual continuous operating and rated voltage:**

- $U_r = U_{i2, \min}$  rounded up to the next value divisible by 3 = 339 kV  
Typically, if an industrial environment is present and there are no requirements for a particularly low protection level, an arrester with a rated voltage of 360 kV would be used in this system. This leads to a considerably more stable layout and nevertheless offers a sufficiently low protection level. This also makes sense against the background that the international network codes currently tend to allow temporary operation at voltages higher than the highest system voltage. For example, the European network code for Central Europe allows the maximum system voltage of  $U_s = 420 \text{ kV}$  to be temporarily exceeded with a value of 440 kV for at least 20 minutes and a maximum of 60 minutes. However, under normal environmental and operating conditions, an arrester with a rated voltage of only 336 kV is also possible and quite common if a slightly modified ("enhanced") TOV capability (e.g.  $k_{\text{tov}, 10 \text{ s}} = 1.05$ ) is used or if it is justified to use a power-frequency versus time characteristic for lower pre-heating and lower prior energy duty (see Appendix 2: [power-frequency versus time characteristic](#)). This dimensioning has also been assumed for the  $U$ - $I$ -characteristic shown in [Figure 2](#).  
→  $U_r = 336 \text{ kV}$
- $U_c = U_r / 1.25^* = 336 \text{ kV} / 1.25^* = 269 \text{ kV}$

**Selecting an MO resistor suitable for  $I_n = 10 \text{ kA}$ , the required repetitive charge transfer rate and rated thermal energy:**

- repetitive charge transfer rating,  $Q_{rs}$ : 2.0 C
- rated thermal energy,  $W_{th}$ : 7 kJ/kV
- MO diameter: 60<sup>\*</sup> mm

$\hat{u}_{10 \text{ kA}}/U_r = 2.35^*$  (This factor can be applied for the MO resistor used when configuring it for the SM class and a low protection level shall be achieved. This dimensioning has also been assumed for the  $U$ - $I$ -characteristic shown in [Figure 2](#).)

#### Height of the MO resistor column:

- $h_{MO} \approx 2250^*$  mm

#### The resulting protective characteristics<sup>\*</sup>:

- lightning impulse protection level, LIPL ( $\hat{u}_{10 \text{ kA}, 8/20 \mu\text{s}}$ ): 790 kV
- switching impulse protection level, SIPL ( $\hat{u}_{1 \text{ kA}, 30/60 \mu\text{s}}$ ): 650 kV

#### Checking the protective values:

- $LIWV_e/LIPL = 1425 \text{ kV}/790 \text{ kV} = 1.8 \rightarrow$  definitely sufficient

#### Selecting a housing:

Minimal requirements:

- lightning impulse withstand voltage of the housing,  $LIWV_h =$
- $1.3 \cdot LIPL = 1.3 \cdot 790 \text{ kV} = 1027 \text{ kV}$
- with specific flashover distance  $\approx 500 \text{ kV/m} \rightarrow s_{si} \approx 2055 \text{ mm}$
- switching impulse withstand voltage of the housing, wet,  $SIWV_h =$
- $1.25 \cdot SIPL = 1.25 \cdot 650 \text{ kV} = 813 \text{ kV}$
- with flashover distance  $s/m = 2.2 \cdot (e^{U/1069 \text{ kV}} - 1) \rightarrow s_{si} \approx 2565 \text{ mm}$
- $\rightarrow h_{\text{min, arrester}} = s_{si} + 4 \cdot h_{\text{flange}}$  (2 units  $\rightarrow$  4 flanges) (In the EHV and UHV systems, the flashover distances are typically determined by the SIWV requirements.)
- creepage distance:  $25 \text{ mm/kV} \cdot 420 \text{ kV}$  ( $43.3 \text{ mm/kV} \cdot 242.5 \text{ kV}$ ) = 10 500 mm
- permissible head load static (SLL): 400 N
- permissible head load dynamic (SSL): 1 000 N
- rated short-circuit current ( $I_s$ ): 50 kA
- typical housing height: 3 720 mm
- number of units: 2
- grading ring: yes

### Example 5: "Solidly earthed neutral 550 kV system; standard case"

(All the information which is asterisked (\*) are typical. Individually, however, these are manufacturer-dependent values.)

**Tacitly assumed, if no further information is given and no special requests are made:**

- $U_s$ : 550 kV ( $U_n$ : 500 kV)
- lightning impulse withstand voltage of equipment,  $LIWV_e$ : 1 550 kV
- earth fault factor,  $k$ : 1.4
- maximum duration of temporary overvoltage: 10 s
- required nominal discharge current,  $I_n = 20$  kA
- required former line discharge class: 4 or 5
- designation: SH
- required repetitive charge transfer rating,  $Q_{rs}$ : 2.4 C
- rated thermal energy,  $W_{th}$ : 10 kJ/kV
- pollution level: d ("heavy")
- maximum short-circuit current,  $I_s$ : 50 kA

**Determining the minimally required continuous operating and rated voltage:**

- $U_{c, \min} = 1.05 \cdot U_s / \sqrt{3} = 1.05 \cdot 550 / \sqrt{3} \text{ kV} = 333 \text{ kV}$
- $U_{fl, \min} = 1.25^* \cdot U_{c, \min} = 1.25^* \cdot 333 \text{ kV} = 416 \text{ kV}$
- $U_{r2, \min} = 1.4 \cdot (U_s / \sqrt{3}) / k_{\text{tov}, 10 \text{ s}} = 1.4 \cdot (550 / \sqrt{3}) \text{ kV} / 1 = 445 \text{ kV}$

**Establishing the actual continuous operating and rated voltage:**

- $U_r = U_{r2, \min}$  rounded down (!) to the next value divisible by 3 = 444 kV
- $U_c = U_{c, \min} = 355 \text{ kV}$

Normally an arrester with a rated voltage of at least 444 kV is used in this system. Typically, in a 500 kV system, the rated voltage cannot be chosen higher than absolutely necessary, otherwise the protection level would be too high.

**Selecting an MO resistor suitable for  $I_n = 20$  kA, the required repetitive charge transfer rate and rated thermal energy:**

- repetitive charge transfer rating,  $Q_{rs}$ : 3.6 C
- rated thermal energy,  $W_{th}$ : 14 kJ/kV
- MO diameter: 78\* mm
- $\hat{u}_{20 \text{ kA}} / U_r = 2.45^*$

**The resulting protective characteristics\*:**

- lightning impulse protection level, LIPL ( $\hat{u}_{20 \text{ kA}, 8/20 \mu\text{s}}$ ): 1 089 kV
- switching impulse protection level, SIPL ( $\hat{u}_{2 \text{ kA}, 30/60 \mu\text{s}}$ ): 879 kV

**Checking the protective values:**

- $LIWV_e / LIPL = 1\,550 \text{ kV} / 1\,089 \text{ kV} = 1.42 \rightarrow$  just sufficient
- $SIWV_e / SIPL = 1\,175 \text{ kV} / 879 \text{ kV} = 1.34 \rightarrow$  SIPL requirement fulfilled

**Height of the MO resistor column(s):**

- $h_{MO} = 2\,850^* \text{ mm}$

### Selecting a housing:

Minimal requirements:

- lightning impulse withstand voltage of the housing,  $LIWV_h = 1.3 \cdot LIPL = 1.3 \cdot 1\,089 \text{ kV} = 1\,416 \text{ kV}$   
with specific flashover distance  $\approx 500 \text{ kV/m} \rightarrow s_{si} \approx 2\,850 \text{ mm}$
- switching impulse withstand voltage of the housing, wet,  $SIWV_h = 1.25 \cdot SIPL = 1.25 \cdot 879 \text{ kV} = 1\,099 \text{ kV}$   
with flashover distance  $s/m = 2.2 \cdot (e^{U/1069 \text{ kV}} - 1) \rightarrow s_{si} \approx 3\,950 \text{ mm}$   
 $\rightarrow h_{\min, \text{arrester}} = s_{si} + 4 \cdot h_{\text{flange}}$  (2 units  $\rightarrow$  4 flanges) (In the EHV and UHV systems, the flashover distances are typically determined by the SIWV requirements.)
- creepage distance:  $25 \text{ mm/kV} \cdot 550 \text{ kV}$  ( $43.3 \text{ mm/kV} \cdot 317.5 \text{ kV}$ ) =  $13\,750 \text{ mm}$
- permissible head load dynamic (SSL):  $1\,500 \text{ N}$
- permissible head load static (SLL):  $600 \text{ N}$
- rated short-circuit current (rated short-circuit (withstand) current  $I_s$ ):  $50 \text{ kA}$
- typical housing height:  $4520 \text{ mm}$
- number of units: 2
- grading ring: yes

### Example 6: "Solidly earthed neutral 500 kV system; special requirements"

(All the information which is asterisked (\*) are typical. Individually, however, these are manufacturer-dependent values.)

**Tacitly assumed, if no further information had been given and no special requests had been made:**

- $U_n$ : 500 kV
- $U_s$ : 550 kV (standard assumption if just the term "500 kV system" is used)
- lightning impulse withstand voltage of equipment, LIWV<sub>e</sub>: 1 550 kV
- earth fault factor,  $k$ : 1.4
- maximum duration of temporary overvoltage: 10 s
- required nominal discharge current,  $I_n$ : 20 kA
- required former line discharge class: 4 or 5
- designation: SH
- required repetitive charge transfer rating,  $Q_{rs}$ : 2.4 C
- rated thermal energy,  $W_{th}$ : 10 kJ/kV
- pollution level: d ("heavy")
- maximum short-circuit current,  $I_s$ : 50 kA

**Special information and requirements for the particular case:**

- $U_s = 525$  kV
- earth fault factor,  $k$ : 1.3
- switching impulse protection level ( $\hat{u}_{2 \text{ kA}, 30/60 \mu\text{s}}$ ):  $\leq 800$  kV<sup>1</sup>
- thermal energy handling capability:  $\geq 5$  MJ
- creepage distance: 25 mm/kV (of  $U_{ph-ph}$ )
- seismic withstand capability: ground acceleration 0.5 · g according to US standard IEEE 693 (→ arrester base acceleration 1 · g)<sup>2</sup>

**Determining the minimally required continuous operating and rated voltage:**

- $U_{c, \min} = 1.05 \cdot U_s / \sqrt{3} = 1.05 \cdot 525 / \sqrt{3} \text{ kV} = 318 \text{ kV}$
- $U_{rl, \min} = 1.25^* \cdot U_{c, \min} = 1.25^* \cdot 318 \text{ kV} = 398 \text{ kV}$
- $U_{r2, \min} = 1.3 \cdot (U_s / \sqrt{3}) / k_{\text{tov}, 10 \text{ s}} = 1.3 \cdot (525 / \sqrt{3}) \text{ kV} / 1 = 394 \text{ kV}$

**Establishing the actual continuous operating and rated voltage:**

- $U_r = U_{rl, \min}$  rounded up to the next value divisible by 3 = 399 kV
- $U_c = U_{c, \min} = 318$  kV

Normally an arrester with a rated voltage of at least 444 kV is used in a 500 kV system (see example 5). Here, use is made of the detailed specifications of the highest system voltage ( $U_s = 525$  kV) and the earth fault factor ( $k = 1.3$ ), and a lower rated voltage can be used to meet the very low SIPL requirement.

<sup>1</sup> Demands for low switching impulse protection levels are typical of extra-high-voltage systems, see chapter "Configuring MO Arresters".

<sup>2</sup> According to IEEE 693 an arrester's seismic performance is preferably verified by a multi-axes "time history test" on a shaking table. If the arrester is tested without a pedestal (which, for practical reasons, is the usual case) the acceleration at the arrester base must be double the value of the required ground acceleration, assuming an amplification factor of two for a typical pedestal. Furthermore, according to IEEE 693, a mechanical stress of not more than 50% of the arrester's mechanical breaking strength is allowed to occur during the test. These are the reasons that an extremely high mechanical strength is necessary to fulfill the 0.5 · g ground acceleration requirement.

**Selecting an MO resistor suitable for  $I_n = 20$  kA, the required repetitive charge transfer rate and rated thermal energy:**

- repetitive charge transfer rating,  $Q_{rs}$ : 3.6 C
- rated thermal energy,  $W_{th}$ : 14 kJ/kV  $\rightarrow W_{th, arrester} = W_{th} \cdot U_r = 5.6$  MJ  
 $\rightarrow$  requirement met
- MO diameter: 78 mm
- $\hat{u}_{20\text{ kA}}/U_r = 2.45$

**The resulting protective characteristics:**

- lightning impulse protection level, LIPL ( $\hat{u}_{20\text{ kA}, 8/20\ \mu\text{s}}$ ): 978 kV
- switching impulse protection level, SIPL ( $\hat{u}_{2\text{ kA}, 30/60\ \mu\text{s}}$ ): 790 kV

**Checking the protective values:**

- $LIWV_e/LIPL = 1550\text{ kV}/978\text{ kV} = 1.58 \rightarrow$  sufficient
- required  $SIWV_e/SIPL = 800\text{ kV}/790\text{ kV} = 1.01 \rightarrow$  SIPL requirement fulfilled

**Height of the MO resistor column(s):**

- $h_{MO} = 2810$  mm

**Selecting a housing (composite hollow core insulator - "tube design" – in order to fulfill the seismic requirements):**

Minimal requirements:

- lightning impulse withstand voltage of the housing,  $LIWV_h = 1.3 \cdot LIPL = 1.3 \cdot 978\text{ kV} = 1272\text{ kV}$   
with specific flashover distance  $\approx 500\text{ kV/m} \rightarrow s_{si} \approx 2545\text{ mm}$
- switching impulse withstand voltage of the housing, wet,  $SIWV_h = 1.25 \cdot SIPL = 1.25 \cdot 790\text{ kV} = 988\text{ kV}$   
with flashover distance  $s/m = 2.2 \cdot (e^{U/1069\text{ kV}} - 1) \rightarrow s_{si} \approx 3345\text{ mm}$   
 $\rightarrow h_{min, arrester} = s_{si} + 4 \cdot h_{flange}$  (2 units  $\rightarrow$  4 flanges) (In the EHV and UHV systems, the flashover distances are typically determined by the SIWV requirements.)
- creepage distance:  $25\text{ mm/kV} \cdot 525\text{ kV}$  ( $43.3\text{ mm/kV} \cdot 303\text{ kV}$ ) = 13125 mm
- permissible head load dynamic (SSL): 8790 N (due to seismic requirements)
- permissible head load static (SLL): 6150 N (= 70% of the dynamic value)
- rated short-circuit current ( $I_s$ ): 50 kA
- typical housing height: 4320 mm
- number of units: 2
- grading ring: yes

### Example 7: "Resonant earthed or isolated neutral 20 kV system"

(All the information which is asterisked (\*) are typical. Individually however, these are manufacturer-dependent values.)

**Tacitly assumed, if no further information is given and no special requests are made:**

- $U_s$ : 24 kV ( $U_n$ : 20 kV)
- lightning impulse withstand voltage of equipment,  $LIWV_e$ : 125 kV
- operation under earth fault conditions for > 30 min.
- required nominal discharge current,  $I_n$ : 10 kA
- designation: DH
- required repetitive charge transfer rating,  $Q_{rs}$ : 0.4 C
- thermal charge transfer rating,  $Q_{th}$ : 1.1 C
- pollution level: b ("light")
- maximum short-circuit current,  $I_s$ : 20 kA

**Determining the minimally required continuous operating and rated voltage:**

- $U_{c, \min} = U_s = 24$  kV
- $U_{r, \min} = 1.25^* \cdot U_{c, \min} = 1.25^* \cdot 24$  kV = 30 kV  
(The rated voltage, however, has no technical significance in a resonant earthed or isolated system.)

**Establishing the actual continuous operating and rated voltage:**

- $U_r = U_{r, \min}$  rounded up to the next value divisible by 3 = 30 kV
- $U_c = U_r / 1.25^* = 30$  kV / 1.25^\* = 24 kV

**Selecting an MO resistor suitable for  $I_n = 10$  kA, the required repetitive charge transfer rate and thermal charge transfer rating:**

- required repetitive charge transfer rating,  $Q_{rs}$ : 0.4 C
- thermal charge transfer rating,  $Q_{th}$ : 1.1 C
- MO diameter: 36^\* mm
- $\hat{u}_{10 \text{ kA}} / U_r = 2.65^*$  (This factor is characteristic for the MO resistor used.)

**The resulting protective characteristics\*:**

- lightning impulse protection level, LIPL ( $\hat{u}_{10 \text{ kA}, 8/20 \mu\text{s}}$ ): 80 kV

**Checking the protective values:**

- $LIWV_e / LIPL = 125$  kV / 80 kV = 1.56 → sufficient

**Height of the MO resistor column:**

- $h_{MO} = 185^*$  mm

**Selecting a housing (polymeric type):**

Minimal requirements:

- lightning impulse withstand voltage of the housing,  $LIWV_h = 1.3 \cdot LIPL = 1.3 \cdot 80 \text{ kV} = 104 \text{ kV}$   
with specific flashover distance  $\approx 500 \text{ kV/m} \rightarrow s \approx 210 \text{ mm}$   
 $\rightarrow h_{\text{min, arrester}} = s + 2 \cdot h_{\text{flange}}$
- power-frequency withstand voltage 1 min, wet,  $ACWV_h = 0.88/\sqrt{2} \cdot LIPL = 0.88/\sqrt{2} \cdot 80 \text{ kV} = 50 \text{ kV}$
- creepage distance:  $16 \text{ mm/kV} \cdot 24 \text{ kV}$  ( $27.7 \text{ mm/kV} \cdot 13.9 \text{ kV}$ )  $\approx 385 \text{ mm}$
- permissible head load static (SLL): 175 N
- permissible head load dynamic (SSL): 250 N
- rated short-circuit current ( $I_s$ ): 20 kA
- typical housing height: 295 mm
- number of units: 1 (In medium voltage this is generally the case.)
- grading ring: for medium voltage arresters this is generally not necessary

### Example 8: "Solidly earthed neutral 20 kV system"

(All the information which is asterisked (\*) are typical. Individually however, these are manufacturer-dependent values.)

**Tacitly assumed, if no further information is given and no special requests are made:**

- $U_s$ : 24 kV ( $U_n$ : 20 kV)
- lightning impulse withstand voltage of equipment, LIWV<sub>e</sub>: 125 kV
- earth fault factor,  $k$ : 1.4
- required nominal discharge current,  $I_n$ : 10 kA
- designation: DH
- required repetitive charge transfer rating,  $Q_{rs}$ : 0.4 C
- thermal charge transfer rating,  $Q_{th}$ : 1.1 C
- pollution level: b ("light")
- maximum short-circuit current,  $I_s$ : 20 kA

**Determining the minimally required continuous operating and rated voltage:**

- $U_{c, \min} = 1.05 \cdot U_s / \sqrt{3} = 1.05 \cdot 24 / \sqrt{3} \text{ kV} = 14.6 \text{ kV}$
- $U_{i, \min} = 1.25^* \cdot U_{c, \min} = 1.25^* \cdot 14.6 \text{ kV} = 18.3 \text{ kV}$
- $U_{i2, \min} = 1.4 \cdot (U_s / \sqrt{3}) / k_{\text{tov}, 10 \text{ s}} = 1.4 \cdot (24 / \sqrt{3}) / 1.0^* \text{ kV} = 19.4 \text{ kV}$

**Establishing the actual continuous operating and rated voltage:**

- $U_r = U_{i, \min}$  rounded up to the next value divisible by 3 = 21 kV
- $U_c = U_r / 1.25^* = 21 \text{ kV} / 1.25^* = 16.8 \text{ kV}$

**Selecting an MO resistor suitable for  $I_n = 10 \text{ kA}$ , the required repetitive charge transfer rate and thermal charge transfer rating:**

- required repetitive charge transfer rating,  $Q_{rs}$ : 0.4 C
- thermal charge transfer rating,  $Q_{th}$ : 1.1 C
- MO diameter: 36\* mm
- $\hat{u}_{10 \text{ kA}} / U_r = 2.65^*$  (This factor is characteristic for the MO resistor used.)

**The resulting protective characteristics\*:**

- lightning impulse protection level, LIPL ( $\hat{u}_{10 \text{ kA}, 8/20 \mu\text{s}}$ ): 56 kV

**Checking the protective values:**

- $LIWV_e/LIPL = 125 \text{ kV}/56 \text{ kV} = 2.15 \rightarrow$  definitely sufficient

**Height of the MO resistor column:**

- $h_{MO} = 130 \text{ mm}$

**Selecting a housing (polymeric type):**

Minimal requirements:

- lightning impulse withstand voltage,  $LIWV_e = 1.3 \cdot LIPL = 1.3 \cdot 56 \text{ kV} = 72.8 \text{ kV}$   
with specific flashover distance  $\approx 500 \text{ kV/m} \rightarrow s \approx 150 \text{ mm}$   
 $\rightarrow h_{\min, \text{arrester}} = s + 2 \cdot h_{\text{flange}}$
- power-frequency withstand voltage 1 min, wet,  $ACWV_h = 0.88/\sqrt{2} \cdot LIPL = 0.88/\sqrt{2} \cdot 56 \text{ kV} = 34.8 \text{ kV}$
- creepage distance:  $16 \text{ mm/kV} \cdot 24 \text{ kV}$  ( $27.7 \text{ mm/kV} \cdot 13.9 \text{ kV}$ )  $\approx 385 \text{ mm}$
- permissible head load static (SLL): 175 N
- permissible head load dynamic (SSL): 250 N
- rated short-circuit current ( $I_s$ ): 20 kA
- typical housing height: 240 mm
- number of units: 1 (In medium voltage this is generally the case.)
- grading ring: for medium voltage arresters this is generally not necessary

## Arresters to protect transformer neutral points

Arresters to protect transformer neutral points from overvoltages, or “neutral point arresters” for short, are the most common special application of arresters. For example, the IEC 60099-5 application guide recommends the use of an arrester to protect each unearthed neutral point from lightning and switching overvoltage if the neutral point is accessible through a bushing. Following the very detailed explanation of the configuration of phase arresters, the particular features of neutral point arresters are only covered briefly here. The following statements apply in all cases:

- The thermal energy and the charge transfer rating of neutral point arresters should at least be the same as for the associated phase arresters.
- In extended resonance-earthed systems, neutral arresters may be subjected to very high charges and energies, possibly higher than those of the phase arresters. System studies are recommended to specify the requirements on the arresters in such cases.
- The 1 kA residual voltage level can be used as the protection level because higher currents do not occur.
- The safety margin between the lightning impulse withstand voltage (LIWV) of the transformer neutral point and the arrester protection level can be smaller than for the phase arresters because the voltage increases are not fast enough for traveling wave processes to become a concern.
- For a fully insulated transformer neutral point, IEC 60099-5 recommends choosing a rated voltage for neutral point arresters that is equal to about 60% that of the related phase arresters  $U_{r, \text{Np-A}} \approx 0.6 \cdot U_{r, \text{Ph-A}}$
- However, to provide relief for the phase arresters, neutral point arresters and phase arresters can be coordinated so that in the case of intermittent earth faults, for example, the neutral point arresters act more quickly than the phase arresters, thus relieving the phase arresters. In this case the recommendation is  $U_{r, \text{Np-A}} \approx 0.45 \cdot U_{r, \text{Ph-A}}$ , in other words the rated voltage of the neutral point arresters is only about 45% that of the phase arresters. This approach is frequently used in Germany. Of course, this means that the neutral point arresters have a higher risk of overload, and indeed, neutral point arresters are the only high-voltage arresters with a failure rate significantly higher than zero (deliberately!). For this reason, arresters configured in this way must be contained in a housing with extremely high short-circuit withstand capability. For example, arresters with polymer housing offer maximum safety in this respect, preferably using the “tube design”.

Each national version of the IEC 60099-5 application guide for surge arresters usually contains tables in Annex B showing the arrester characteristics, which are common in that country, for phase arresters as well as neutral point arresters. Please refer to these tables for typical neutral point arresters.

## Standards

The selection below describes the current state of the most important IEC (and some other) standards on arresters and the associated topics.

Since January 1997, the IEC publications have been numbered differently, in order to achieve correspondence to European and international standards. This is done by adding the number 60000 to the old number. The same holds true for the publications published before 1997, even if they currently still have the old number.

The US standards and application guides on arresters and insulation coordination have also been included because of their importance for the American and other national markets.

### *a) IEC arrester standards*

---

#### **IEC 60099-1, Edition 3.1, 1999-12**

##### **(Edition 3: 1991 consolidated with amendment 1: 1999)**

Surge arresters – Part 1: Non-linear resistor type gapped surge arresters for a.c. systems

*Note:* This standard has been withdrawn in 2013.

---

#### **IEC 60099-4, Edition 3.0, 2014-06**

Surge arresters – Part 4: Metal-oxide surge arresters without gaps for a.c. systems

---

#### **IEC 60099-5, Edition 3.0, 2018-01**

Surge arresters – Part 5: Selection and application recommendations

---

#### **IEC 60099-6, Edition 2.0, 2019-05**

Surge arresters – Part 6: Surge arresters containing both series and parallel gapped structures – Rated 52 kV and less

*Note:* This standard was not accepted by CENELEC, and therefore no European Standard (EN) version exists. The standard covers a very specific design of internally gapped MO arresters, which are applied mainly in the American market.

---

#### **IEC 60099-8 Ed. 2.0, 2017-11**

Surge arresters - Part 8: Metal-oxide surge arresters with external series gap (EGLA) for overhead transmission and distribution lines of a.c. systems above 1 kV

*Note:* This standard will be replaced by the joint logo standard **IEC/IEEE 60099-11: Surge Arresters - Part 11: Metal-oxide Surge Arresters to Protect Power Line Insulation**, which will cover all types of line arresters and is expected to be published in 2024.

---

#### **IEC 60099-9, Edition 1.0, 2014-06**

Surge arresters – Part 9: Metal-oxide surge arresters without gaps for HVDC converter stations

---

#### **Project IEC TR 60099-10**

Surge arresters – Part 10: Test rationale of 60099-4 (working title)

Maintenance Team 10 (MT10) of TC37 is currently working on a Technical Report (TR) to provide background and rationale for surge arrester tests prescribed in IEC 60099-4. For each type test and routine test TR will include:

- The purpose of the test
  - The general rationale for the test
  - Historical notes
  - Justifications regarding the test requirements (sample selection, test evaluation, etc.)
-

**b) IEC standards on insulation coordination**

---

**IEC 60071-1, Ed. 9.0, 2019-08**

Insulation co-ordination – Part 1: Definitions, principles and rules

---

**IEC 60071-2, Ed. 4.0, 2018-03**

Insulation co-ordination – Part 2: Application guide

---

**IEC TR 60071-4, Ed. 1.0: 2004-06**

Insulation co-ordination – Part 4: Computational guide to insulation co-ordination and modelling of electrical networks

---

**IEC TS 60071-11, Ed. 1.0, 2022-11**

Insulation co-ordination - Part 11: Definitions, principles and rules for HVDC system

---

**IEC TS 60071-12, Ed. 1.0, 2022-10**

Insulation co-ordination - Part 12: Application guidelines for LCC HVDC converter stations

---

**c) Other international and national standards, also relevant for arresters**

---

**IEC 60060-1, Ed. 3.0, 2010-09**

High-voltage test techniques. Part 1: General definitions and test requirements

---

**IEC 60507, Ed. 3.0, 2013-12**

Artificial pollution tests on high-voltage insulators to be used in a.c. systems

---

**IEC 60672-3, Second Edition, 1997-10**

Ceramic and glass-insulating materials – Part 3: Specifications for individual materials

---

**IEC/TS 60815-1, Ed. 1.0, 2008-10**

Selection and dimensioning of high-voltage insulators intended for use in polluted conditions - Part 1: Definitions, information and general principles

**IEC/TS 60815-2 Ed. 1.0, 2008-10**

Selection and dimensioning of high-voltage insulators intended for use in polluted conditions - Part 2: Ceramic and glass insulators for a.c. systems

**IEC/TS 60815-3 Ed. 1.0, 2008-10**

Selection and dimensioning of high-voltage insulators intended for use in polluted conditions - Part 3: Polymer insulators for a.c. systems

**IEC/TS 60815-4 Ed. 1.0, 2016-10**

Selection and dimensioning of high-voltage insulators intended for use in polluted conditions - Part 4: Insulators for d.c. systems

---

**DIN 48 113, 1973-09**

Stützisolatoren für Schaltgeräte und Schaltanlagen für Spannungen über 1 kV – Zuordnung der Begriffe für Biegefestigkeit  
(Post insulators for switchgear and substations with nominal voltages greater than 1000 V; co-ordination of the definitions for mechanical bending strength)

---

**HD 637 S1:1999**

Power installations exceeding AC 1 kV

**IEC 61936-1, Ed. 3.0, 2021-07**

Power installations exceeding 1 kV AC and 1,5 kV DC - Part 1: AC

**IEC 61936-2, Ed. 1.0, 2015-03**

Power installations exceeding 1 kV a.c. and 1,5 kV d.c. - Part 2: d.c.

---

**IEC 62073, Ed. 2.0, 2016-02**

Guidance on the measurement of wettability of insulator surfaces

---

**d) American arrester standards**

---

**IEEE C62.11-2020**

IEEE Standard for Metal-Oxide Surge Arresters for AC Power Circuits (> 1 kV)

*Note:* This standard, in contrast to IEC 60099-4, IEC 60099-6 and IEC 60099-8, applies to both MO arresters with and without gaps.

---

**IEEE Std. C62.22-2009**

IEEE Guide for the Application of Metal-Oxide Surge Arresters for Alternating-Current Systems

**IEEE Std. C62.22a-2013**

IEEE Guide for the Application of Metal-Oxide Surge Arresters for Alternating-Current Systems – Amendment 1: Supplement to Consider Energy Handling Capabilities

## Further reading

Consult the following literature for further information on MO arresters and resistors and their applications:

**CIGRE Technical Brochure 34**

Guidelines for the applications of metal oxide arresters without gaps for HVDC converter stations  
1989

**CIGRE Technical Brochure 60**

Metal Oxide Arresters in AC Systems  
April 1991

**CIGRE Technical Brochure 440**

Use of Surge Arresters for Lightning Protection of Transmission Lines  
December 2010

**CIGRE Technical Brochure 455**

Aspects for the Application of Composite Insulators to High Voltage ( $\geq 72$  kV) Apparatus  
April 2011

**CIGRE Technical Brochure 544**

MO Surge Arresters – Stresses and Test Procedures  
August 2013

**CIGRE Technical Brochure 549**

Lightning Parameters for Engineering Applications  
August 2013

**CIGRE Technical Brochure 696**

MO Surge Arresters – Metal Oxide Resistors and Surge Arresters for Emerging System Conditions  
August 2017

**CIGRE Technical Brochure 855**

Effectiveness of line surge arresters for lightning protection of overhead transmission lines  
December 2021

**CIGRE Working Group 33.06**

Metal oxide surge arresters in AC systems  
Part 1: General properties of the metal oxide surge arrester  
Part 2: Performance of metal oxide surge arresters under operating voltage  
Part 3: Temporary overvoltages and their stresses on metal oxide surge arresters  
ELECTRA 128, pp. 99-125

**CIGRE Working Group 33.06**

Metal oxide surge arresters in AC systems  
Part 4: Stresses in metal oxide surge arresters due to temporary harmonic overvoltages  
ELECTRA 130, pp. 78-115

**CIGRE Working Group 33.06**

Metal oxide surge arresters in AC systems  
Part 5: Protection performance of metal oxide surge arresters  
Part 6: Selection of metal oxide surge arrester characteristics from the standards  
ELECTRA 133, pp. 133-165

**M. Bröker, V. Hinrichsen**

Testing Metal-Oxide Varistors for HVDC Breaker Application  
IEEE Transactions on Power Delivery, vol. 34, no. 1, pp. 346-352, Feb. 2019, doi:  
10.1109/TPWRD.2018.2877464.

**M. Gießel, V. Hinrichsen, R. Göhler, Y. Späck-Leigsnering, E. Gjonaj, H. De Gersem**

Electro-Thermally Coupled Finite-Element Simulations of High Voltage Station Arresters with and without Grading  
INMR World Congress, Barcelona-Sitges, Spain, Nov. 5-8, 2017

**R. Göhler, M. Schubert, K.-H. Weck, V. Hinrichsen, M. Tuczek, M. Clemens, R. Appel**

Special Requirements on Surge Arrester Design for UHV A.C. Systems above 800 kV System Voltage  
CIGRE Session 2010, Paris, Report A3-104-2010

**C. Heinrich, V. Hinrichsen**

Diagnostics and Monitoring of Metal-Oxide Surge Arresters in High-Voltage Networks - Comparison of Existing and Newly Developed Procedures  
IEEE Transactions on Power Delivery, Vol. 16, No. 1, January 2001, pp. 138-143

**V. Hinrichsen, R. Göhler, H. Lipken, W. Breilmann**

Economical overvoltage protection by metal-oxide surge arresters integrated in 420-kV centre-break disconnectors - Substation integration, design and test experience  
CIGRE Session 2000, Paris, Report 33-104

**V. Hinrichsen**

Latest Designs and Service Experience with Station-Class Polymer Housed Surge Arresters  
World Conference on Insulators, Arresters & Bushings, Marbella (Málaga), Spain,  
November 16-19, 2003, Proceedings pp. 85-96

**V. Hinrichsen**

Latest Test Requirements and Emerging Standards for Transmission Line Arresters  
World Conference on Insulators, Arresters & Bushings, Hong Kong, November 27-30, 2005

**V. Hinrichsen**

Overview of Recent Technological Developments for HV Line and Station Arresters & Future Tendencies  
World Conference on Insulators, Arresters & Bushings, Rio de Janeiro, May 14-16, 2007

**V. Hinrichsen, M. Reinhard, B. Richter (on behalf of CIGRE WG A3.17)**

Energy Handling Capability of High-Voltage Metal-Oxide Surge Arresters - Part 1: A Critical Review of the Standards  
CIGRE SC A3 Technical Colloquium, Rio de Janeiro, September 12/13, 2007

**V. Hinrichsen**

Testing Requirements and Actual IEC Work on Distribution and Transmission Line Arresters  
CIGRE Colloquium "Application of Line surge Arresters in Power Distribution and Transmission Systems", Cavtat/Croatia, May 26 to 29, 2008

**V. Hinrichsen, R. Göhler, M. Clemens, T. Steinmetz, P. Riffon**

External Grading Systems for UHV Metal-Oxide Surge Arresters - A New Approach to Numerical Simulation and Dielectric Testing  
CIGRE Session 2008, Paris, Report A3-205

**V. Hinrichsen, M. Tuczek, M. Reinhard**

Recent Experimental Findings on the Energy Handling Capability of Metal-Oxide Varistors for High-Voltage Applications  
World Congress on Insulators, Arresters and Bushings, Crete, May 10-13, 2009

**V. Hinrichsen, N. Möhring, T. Wietoska, H. Haupt, A. Bockenheimer, C. Heinemann, C. Berger, I. Gottschalk, N. Kurda, N. Mikli, F. Schmuck, J. Seifert**

Resistance to Vapor Permeation of Factory New and of Mechanically Stressed Composite Hollow Insulators

CIGRE Session 2010, Paris, Report A3-304-2010

**V. Hinrichsen, M. Tuczek**

Evaluation of MO Resistors in Respect to Energy Handling Capabilities

World Congress on Insulators, Arresters, Bushings and Cable Accessories, Munich, Oct. 18-21, 2015

**V. Hinrichsen, M. Gießel, M. Tuczek**

Thermal Stability of HV and UHV Arresters with Reduced Grading Systems

World Congress on Insulators, Arresters, Bushings and Cable Accessories, Munich, Oct. 18-21, 2015

**V. Hinrichsen**

Arrester Technology Today: Lessons Learned and Developments to Watch

INMR World Congress, Tucson, Arizona, USA, Oct. 20-23, 2019

**P. Hock, N. Belda, V. Hinrichsen, R. Smeets**

Investigations on Metal-Oxide Surge Arresters for HVDC Circuit Breaker Applications

INMR World Congress, Tucson, Arizona, USA, Oct. 20-23, 2019

**M. Reinhard, V. Hinrichsen, B. Richter, F. Greuter (on behalf of Cigré WG A3.17)**

Energy Handling Capability of High-Voltage Metal-Oxide Surge Arresters - Part 2: Results of a Research Test Program

CIGRE Session 2008, Paris, Report A3-309

**B. Richter, W. Schmidt, K. Kannus, K. Lahti, V. Hinrichsen, C. Neumann, W. Petrusch, K. Steinfeld**

Long Term Performance of Polymer Housed MO-Surge Arresters

CIGRE Session 2004, Paris, Report A3-110

**Y. Späck-Leigsnering, E. Gjonaj, H. De Gersem, T. Weiland, M. Gießel, V. Hinrichsen**

Investigation of Thermal Stability for a Station Class Surge Arrester

IEEE Journal on Multiscale and Multiphysics Computational Techniques, vol. 1, pp. 120-128, 2016, doi: 10.1109/JMMCT.2016.2636250.

**Y. Späck-Leigsnering, E. Gjonaj, H. De Gersem, T. Weiland, M. Gießel and V. Hinrichsen**

Electroquasistatic-Thermal Modeling and Simulation of Station Class Surge Arresters

IEEE Transactions on Magnetics, vol. 52, no. 3, pp. 1-4, March 2016, Art no. 9100104, doi: 10.1109/TMAG.2015.2490547.

**Y. Späck-Leigsnering, M.G. Ruppert, E. Gjonaj, H. De Gersem and V. Hinrichsen**

Simulation Analysis of Critical Parameters for Thermal Stability of Surge Arresters in IEEE Transactions on Power Delivery, vol. 37, no. 2, pp. 871-879, April 2022, doi: 10.1109/TPWRD.2021.3073729.

**M. Tuczek, V. Hinrichsen**

Recent Experimental Findings on the Single and Multi-Impulse Energy Handling Capability of Metal-Oxide Varistors for Use in High-Voltage Surge Arresters

IEEE Transactions on Power Delivery, vol. 29, no. 5, pp. 2197-2205, Oct. 2014, doi: 10.1109/TPWRD.2013.2283911.

**M. Tuczek, M. Bröker, V. Hinrichsen, R. Göhler**

Effects of Continuous Operating Voltage Stress and AC Energy Injection on Current Sharing Among Parallel-Connected Metal–Oxide Resistor Columns in Arrester Banks

IEEE Transactions on Power Delivery, vol. 30, no. 3, pp. 1331-1337, June 2015, doi:  
10.1109/TPWRD.2014.2365045.

**M. Tuczek**

Experimentelle Untersuchungen zur Mehrfachimpulsbelastbarkeit von Metalloxidvaristoren für Anwendungen in der elektrischen Energietechnik

Dissertation TU Darmstadt, 2015

*English translation:*

Experimental Investigations of the Multiple Impulse Energy Handling Capability of Metal-Oxide Varistors for Applications in Electrical Power Engineering

<https://tuprints.ulb.tu-darmstadt.de/8455/>

## Appendix 1: The former line discharge class system

In addition to the nominal discharge current  $I_n$  the line discharge class (LD class) was the actual determining characteristic of a high-voltage arrester up to IEC 60099-4 Ed. 2.2. It was the only way of specifying the energy handling capability of an arrester in accordance with the standard. It was, however, only indirectly found within the value of the line discharge class. The relationship is relatively difficult to understand. This had, in the end, prompted almost all the manufacturers to include more details on the energy handling capability – like the [long-duration current impulse withstand capability](#) – in their catalogues, than those provided in IEC standards<sup>1</sup>. But as such definitions, specifications and the associated test procedures for their verification were not standardized at all this information was often confusing or even misleading and not always helpful to the users, who wanted to compare and to 'select arresters from different makes and manufacturers. One of the most important innovations of IEC 60099-4 Ed. 3.0, published in 2014, in terms of energy handling capability was, therefore, the clear definition and distinction between impulse and thermal energy handling capability, expressed in terms of the repetitive charge transfer rating,  $Q_{rs}$ , the thermal energy rating,  $W_{thr}$ , and the thermal charge transfer rating,  $Q_{th}$ . Their choice and selection is covered in the main body of this guide. A brief overview of the former system of line discharge classes should be given here, against the background that countless station arresters according to the line discharge class system are still in use. All technical details and standard regulations of this appendix refer to IEC 60099-4 Ed. 2.2, which was the latest edition of the standard before the introduction of the new concept with Ed. 3.0. Part of this information has also been included as an informative Annex in IEC 60099-4 Ed. 3.0.

The definition of the line discharge class is based on the assumption that a long transmission line, charged to a certain overvoltage during a switching operation, will discharge into a connected arrester in the form of a [traveling wave process](#). Assuming the equivalent circuit diagram of a line is an iterative network of  [\$\pi\$ -elements](#), formed by inductances and capacitances, the current will flow at a value which is determined by the voltage value and the surge impedance of the line, for a duration given by the length of the line and the propagation speed of an electro-magnetic wave. Ideally, it adjusts to a rectangular-shaped current impulse. This process had to be simulated in a laboratory in a [line discharge test](#). In this case the current impulse was normally generated with the help of a [distributed constant impulse generator](#), which is nothing more than the line simulation made up of a series connection of a finite number – about 10 to 30 – of  $\pi$ -elements. The IEC standard 60099-4 Ed. 2.2 defined five different line discharge classes. Increasing demands were made on the arrester from class one to class five, in which the electrical parameters of the impulse generator were established for the test (**Table 10**):

**Table 10:** Line discharge classes and associated testing parameters in IEC 60099-4 Ed. 2.2

Line discharge class	Surge impedance of the line $Z$ in $\Omega$	Virtual duration of peak $T$ in $\mu s$	Charging voltage $U_L$ in kV (d.c.)
1	$4.9 \cdot U_r$	2000	$3.2 \cdot U_r$
2	$2.4 \cdot U_r$	2000	$3.2 \cdot U_r$
3	$1.3 \cdot U_r$	2400	$2.8 \cdot U_r$
4	$0.8 \cdot U_r$	2800	$2.6 \cdot U_r$
5	$0.5 \cdot U_r$	3200	$2.4 \cdot U_r$

$U_r$  = rated voltage of the test sample as an r.m.s. value in kV

<sup>1</sup> The line discharge class system actually was first used for gapped arresters with current-limiting series gaps. At the beginning of the 1980's – when MO arrester technology was still in its infancy – a testing standard for MO arresters was developed, and the existing system was adopted, since there were no better alternatives. After such a system is introduced, it is difficult to change it again. In the standardization process, new definitions for energy handling capability, however, have been considered, which are more appropriate for stresses associated with today's arrester applications.

These parameters are derived from typical characteristic values of high-voltage transmission lines<sup>1</sup>. This table was the only definition of the line discharge classes in the IEC standard! However, no direct conclusions about the energy stress which is imposed on the arrester during a test can be drawn from it. For that reason the standard provided an additional diagram which represented the converted energy in a test object, with reference to its rated voltage<sup>2</sup>, which occurs during a single line discharge<sup>3</sup>. This energy is not a fixed value, but instead depends on the arrester protection level, or more precisely, on the switching impulse residual voltage  $U_{res}$  with the smaller switching current impulses from Table 4 of IEC 60099-4 Ed. 2.2 (these were  $\hat{i} = 125$  A for 10 kA arresters of LD classes 1 and 2,  $\hat{i} = 250$  A for 10 kA arresters of LD class 3, and  $\hat{i} = 500$  A for 20 kA arresters of LD classes 4 and 5). The higher this residual voltage, the less energy the arrester absorbs during the line discharge, since the line will discharge less intensely when the residual voltage is higher. The diagram referred to is depicted in **Figure 28**.

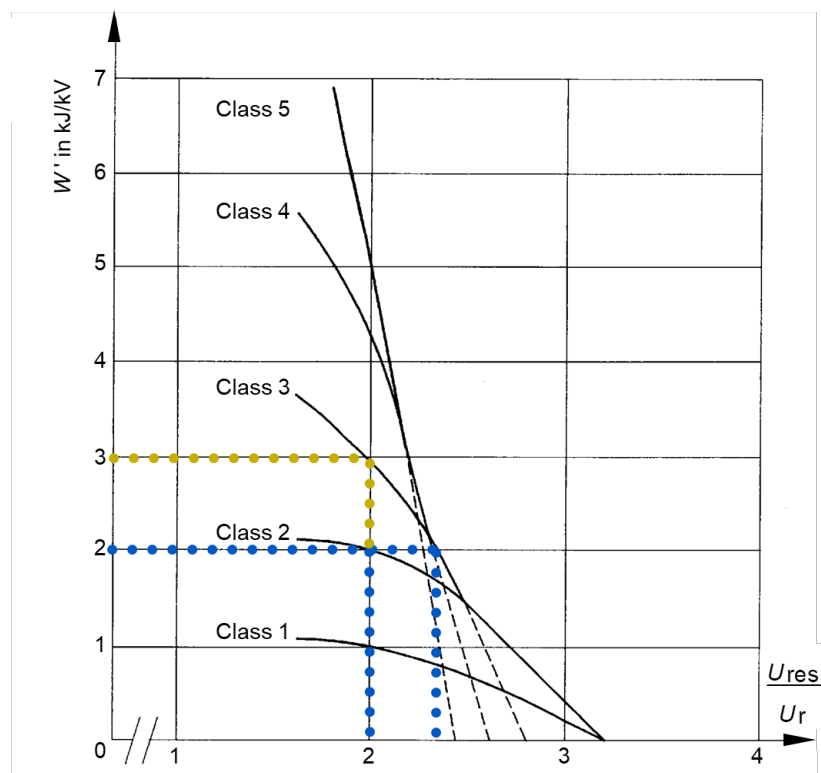

**Figure 28:** Specific energy in kJ/kV of rated voltage dependent on the ratio of switching impulse residual voltage  $U_{res}$  to the r.m.s. value of the rated voltage  $U_r$  of the arrester (IEC 60099-4 Ed. 2.2)

It is now possible to easily identify the problem when the energy handling capability is specified with the help of the line discharge class. If an arrester is considered with a given amount of specific energy handling capability (even though not explicitly stated, it is the specific *thermal* energy handling capability), then the arrester can, depending on the residual voltage it has, be assigned to different line

<sup>1</sup> Also see IEC 60099-1, Ed. 3.1 (withdrawn), Table C.1 or IEC 60099-5, Ed. 1.1 (withdrawn), Table 1.

<sup>2</sup> It is common – in the standard IEC 60099-4 as well – to use the rated voltage when referring to specific energy. Some manufacturers, however, use the continuous operating voltage as the reference value, due to, among other things, the fact that the rated voltage is not defined in the US arrester standard, IEEE C62.11 (instead, a “duty cycle voltage rating” is specified there, whose definition is different from that of the rated voltage in the IEC standard).

<sup>3</sup> During the [switching surge operating duty test](#), which had to be performed on arresters of line discharge classes 2 to 5, the test object had to be subjected to **two** of these discharges within an interval of about one minute. That means an arrester had to be able to absorb at least twice the amount indicated in the diagram, without becoming thermally unstable.

discharge classes. The following example proves this (the blue dotted lines in Figure 28): when using a combination of MO resistors and housing, which can absorb 2 kJ/kV of energy per line discharge (i.e., double the value, namely 4 kJ/kV, during the operating duty test – performed with two successive line discharges – without becoming thermally unstable), the arrester has a line discharge class of two at a ratio of  $U_{res}/U_r = 2$ . However, with exactly the same combination of MO resistors and housing it already can be assigned to line discharge class three at the ratio of  $U_{res}/U_r = 2.35$ . But the seemingly “better” arrester with the line discharge class of three might possibly be worse for the planned application, since its protection level is higher! In order to reach the line discharge class of three while maintaining a ratio of  $U_{res}/U_r = 2$ , a combination of MO resistors and housing must be used with an energy handling capability of almost 6 kJ/kV (about 3 kJ/kV per discharge: the orange dotted lines in Figure 28), which typically means the use of MO resistors with greater diameters.

Inversely, one can only draw conclusions from the line discharge class in connection with the residual voltage as to the energy handling capability of an arrester, and thus about the used MO resistors. It is important to make these interdependencies clear when selecting an arrester according to the line discharge classification system.

As long as there were no particularly easy or difficult requirements originating from the system, the following line discharge classes, depending on the system voltage, were recommended (IEC 60099-5) (**Table 11**):

**Table 11:** Guide values for line discharge classes depending on system voltage

Line discharge class	$U_s$ / kV
1	$\leq 245$
2	$\leq 300$
3	$\leq 420$
4	$\leq 550$
5	$\leq 800$

In practice, however, one frequently tended to select the next higher line discharge class, respectively, in the table. That led to the problem of line discharge class five frequently not meeting the demands of the extra high voltage (EHV) systems with  $U_s > 550$  kV. In fact, at this voltage level, sometimes even at the 550 kV level itself, but in any case in the ultra high voltage (UHV) levels with  $U_s > 800$  kV, MO resistor diameters and/or parallel connections of resistors have to be used that result in a much greater energy handling capability than required for line discharge class 5. For these systems it is, however, common to determine the requirements on the energy handling capability with detailed system studies, so that an exact value for the energy handling capability, instead of the line discharge class, is specified by the user here. But the need to also cover arresters for UHV systems was again a reason to leave the traditional line discharge class system.

When deciding on a definite line discharge class – and thereby indirectly on a definite thermal energy handling capability – the required MO resistor diameter could automatically be selected. The following classification is a rough orientation (**Table 12**):

**Table 12:** Typical assignment of MO resistors to line discharge classes

MO resistor diameter in mm	Line discharge class
50	1 and 2
60	2 and 3
70	3 and 4
80	4 and 5
100 (or 2 · 70 in parallel)	5 and higher

An *impulse* energy handling capability was up to IEC 60099-4 Ed. 3.0 not explicitly defined. The standard just stipulated a [long-duration current impulse withstand test](#). Accordingly, three specimens, i.e. individual MO resistors, had to be tested with 18 current impulse stresses each. For 20 kA and 10 kA arresters, these were the specified line discharge currents, i.e. those [long-duration current impulses](#) that result from Table 10 for the respective line discharge classes, as well as tests with long-duration current impulses for 5 kA and 2.5 kA arresters, with very low amplitudes and durations, though. In any case, the required stresses were far below what the MO resistors could actually withstand in terms of impulse charge stress. For this reason, practically all manufacturers provided additional information on the [long-duration current impulse withstand capability](#) with the actually possible limit impulse charges. However, the manufacturers were free to define the test requirements themselves, making it difficult to compare these values with one another. In particular, these impulse stresses were typically far lower than what is required by the current standard IEC 60099-3, Ed. 3.0, to be proven in the test of the repetitive charge transfer rating,  $Q_{rs}$ .

The explanations of the former system of line discharge classes end here. It should be pointed out, however, that in IEC 60099-4, Ed. 3.0, a detailed Appendix L has been included, which also explains the former line discharge class system and in particular offers examples of how to convert from the former dimensioning with line discharge classes to the current approach of the energy handling capability, using  $Q_{rs}$  and  $W_{th}$  as decisive parameters.

## Appendix 2: MO arresters in brief

This part of the arrester handbook explains the most important terms used in arrester technology and others associated with this technology<sup>1</sup>.

**Abnormal service conditions:** are defined in IEC 60099-4, Annex A. Typical information given with enquiries and tenders is also included in IEC 60099-4, Annex D. Also see → [normal service conditions](#).

**Acceptance tests:** According to IEC 60099-4, the following standard tests are carried out on MO arresters without gaps, if acceptance tests have been arranged for. They must be performed on the nearest lower whole number to the cube root of the total quantity of arresters to be supplied:

- Measurement of power-frequency voltage on the complete arrester at the → [reference current](#)
- Measurement of the → [lightning impulse residual voltage](#) on the complete arrester or on the individual → [arrester units](#), if possible at → [nominal discharge current](#)
- → [Internal partial discharge test](#) on the complete arrester or on the individual → [arrester units](#)
- Tightness test

**Active part of an arrester:** the MO resistor column(s) of an arrester, including metallic spacers and the supporting construction.

**Alumina porcelain:** a type of porcelain in accordance with subgroups "C 120: aluminous porcelains" and "C 130: aluminous porcelains, high strength" of the standard IEC 60672-3.

**ANSI:** American National Standards Institute

**Arcing distance:** → [flashover distance](#)

**Arrester class:** Arresters are classified according to IEC 60099-4, Ed. 3.0, Table 1:

Arrester class	Station			Distribution		
	SH	SM	SL	DH	DM	DL
Nominal discharge current (kA)	20	10	10	10	5	2.5
Switching impulse discharge current (kA)	2	1	0.5	-	-	-
$Q_{rs}$ (C)	≥ 2.4	≥ 1.6	≥ 1.0	≥ 0.4	≥ 0.2	≥ 0.1
$W_{th}$ (kJ per kV of rated voltage)	≥ 10	≥ 7	≥ 4	-	-	-
$Q_{th}$ (C)	-	-	-	1.1	0.7	0.45

**Arrester disconnecter:** → [disconnecter](#)

**Arrester section:** → [section of an arrester](#)

**Arrester unit:** → [unit of an arrester](#)

<sup>1</sup> Underlined terms represent keywords (hyperlinks), which are further explained in greater detail. In the electronic version of the handbook, clicking on the terms will automatically call up the definitions.

**Axial voltage distribution of an arrester:** When operated with AC voltage (i.e. in the leakage current range of the  $U$ - $I$ -characteristic), the earth capacitances acting on an arrester cause the voltage to be unevenly distributed along the arrester. The MO resistors in the upper part of the arrester are subjected to higher voltage stress than those in the lower part. This effect begins to be noticeable from heights of two meters and becomes more and more extreme with increasing arrester heights. However, due to the non-linear behavior of the MO resistors, it is not possible to allow arbitrarily high voltages across the MO resistors, as this means that they are driven well into the resistive range of their  $U$ - $I$ -characteristic, so that high power losses can be converted and strong local temperature increases are the result. Typically, the voltage imbalance is therefore counteracted with grading rings that reduce the influence

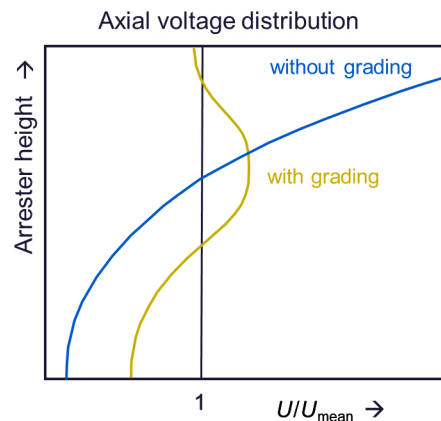

of the earth capacitances. The representation here shows the conditions in an outdoor arrester with and without a grading ring when using a purely capacitive equivalent circuit diagram as a basis. The vertical line shown for  $UIU_{\text{mean}} = 1$  corresponds to an ideal, uniform voltage distribution. However, because the MO resistors do not behave purely capacitively, but also show resistive behavior with increasing voltage applied, a certain self-grading effect occurs even without a grading ring, albeit at the cost of increased power losses and operating temperatures in the upper part of the arrester. Annex F of IEC 60099-4 describes in detail how this behavior can be modeled. The actual voltage distribution must be adequately taken into account in many tests of the arrester.

**Back flashover:** flashover of a line insulator caused by the potential rise of a tower or pole during a lightning strike to the overhead ground or shield wire, or to the tower or pole itself. Back flashovers are particularly common when high tower footing impedances are present, since they cause high voltage drops during the flow of lightning discharge current. → [Line arresters](#) are a possible countermeasure.

**Basic lightning impulse insulation level:** → [BIL](#)

**Basic switching impulse insulation level:** → [SIL](#)

**BIL:** abbreviation for “basic lightning impulse insulation level”. Even though this term is frequently used also when referring to → [IEC](#) standards, it is only defined by → [IEEE](#) and → [ANSI](#) (see e.g. standards IEEE Std 1313.1, IEEE Std C62.2, IEEE Std C62.22, ANSI C92.1). The IEC standard 60071-1 uses the term → [standard rated lightning impulse withstand voltage](#) instead, abbreviated to → [LIWV](#).

**C 110:** → [quartz porcelain](#)

**C 120:** → [alumina porcelain](#)

**C 130:** → [alumina porcelain](#)

**Classification of arresters:** → [arrester class](#)

**Composite hollow core insulator:** a hollow core insulator made out of an → [FRP](#) tube with applied polymeric sheds. The FRP tube can be of the → [wet-processed](#) or → [vacuum-impregnated](#) type. The

sheds almost always consist of →[silicone rubber](#), with differences between →[RTV silicone rubber](#), →[HTV silicone rubber](#), and →[LSR/LR](#). They are applied using different manufacturing processes: →[push-on method](#), →[direct molding](#).

**Conditioning:** Conditioning is a part of the →[operating duty test](#) and takes place before the actual proof of →[thermal stability](#), after energy has been injected. It should cause possible →[electrical ageing](#) (degradation) to occur, so that the actual operating duty test is not carried out in a simplified manner on brand new MO resistors. The conditioning consists of one or two →[high current impulses](#) with peak values of 100 kA, 65 kA or 25 kA, depending on the →[nominal discharge current](#)  $I_n$  of the arrester. In former editions of the standards a conditioning stress with twenty lightning current impulses was also required, but this was removed in IEC 60099-4 Ed. 3.0 because it is now known that this kind of stress does not cause electrical ageing.

**Continuous operating voltage of an arrester:** (symbol:  $U_c$ ) The continuous operating voltage is the designated permissible root-mean-square value of power-frequency voltage, which is allowed to continuously be applied between the arrester terminals (IEC 60099-4 Ed. 3.0, 3.10).

**Coordination withstand voltage:** (symbol:  $U_{cw}$ ) a term from the →[insulation coordination](#): value of the →[withstand voltage](#) of an insulation configuration in actual service conditions, for which an acceptable failure rate (the so-called “performance criterion”) results. The application of surge arresters ensures that the value of the coordination withstand voltage is never exceeded at the terminals of the device to be protected. For an exact definition of the terms mentioned above, and their meaning and determination during the process of insulation coordination, see IEC 60071-1 and 60071-2.

**Corona ring:** electrostatic shielding of the arrester connection at the high-voltage end, to reduce the →[radio interference voltage](#) (RIV). Not to be confused with a →[grading ring](#). See the figure there.

**Creepage (distance):** The creepage (distance) of an insulator is the distance between the metal end fittings, measured along the housing surface (blue path in the figure). It is an important factor in the behavior of an insulator, or a device containing such an insulator in polluted conditions. See also →[guaranteed creepage distance](#), →[nominal creepage distance](#), →[specific creepage distance](#), →[unified specific creepage distance](#), →[flashover distance](#).

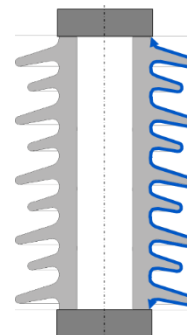

**Current impulse:** unidirectional current impulse, which ideally increases quickly to a peak value and then – generally more slowly – returns to zero. The parameters which define a current impulse are polarity, peak value, →[virtual front time](#)  $T_1$  and →[virtual time to half-value on the tail](#)  $T_2$  in microseconds (exception: →[long-duration current impulse](#), which is characterized by polarity, peak value, virtual duration of the peak and virtual total duration). This is represented as  $T_1/T_2$ , without information about the time unit. For example, the →[lightning current impulse](#) ( $T_1 = 8 \mu\text{s}$ ,  $T_2 = 20 \mu\text{s}$ ) is described as a current of the form 8/20.

**Degradation:** →[electrical ageing](#)

**DH:** →[arrester class](#) “distribution, high duty”

**Dielectrically prorated section:** an arrester section for internal dielectric strength tests.

This type of section was introduced with the Ed. 3.0 of IEC 60099-4. The background is as follows: Up to IEC 60099-4 Ed. 2.2, a thermal model of an arrester was defined for the operating duty tests that should correspond to a complete arrester both thermally and dielectrically. Due to this specification, a section (“slice”) of a real arrester with exactly the same cross-section was typically used for this purpose (→[thermal equivalent](#)). Although this had an internal geometry identical to that of the modeled arrester, it was not thermally equivalent at the same time, since too much heat was dissipated via the ends due to the short section (the section length should accommodate only two MO resistors in series). With Ed. 3.0 of IEC 60099-4, the definition of the thermally prorated section was changed in such a way that it can be constructed in any way, regardless of the actual arrester design, as long as it fulfills the

condition of thermal equivalence. But also to be able to test the internal dielectric properties of an arrester, a dielectrically prorated section had to be introduced as well. All tests to prove thermal stability (→[operating duty tests](#)) are carried out on the →[thermally prorated section](#), while the dielectrically prorated section is only used to demonstrate sufficient dielectric strength, e.g. under the impact of a high current impulse, which produces residual voltages of at least 1.3 times the LIPL. According to IEC 60099-4 Ed. 3.0, 7.3.2.2, the dielectrically prorated section shall thus represent a sliced portion of the arrester being modeled, including the MO resistors, the housing and the supporting structure. Its rated voltage shall be at least 3 kV. The section shall be an exact copy of the real arrester with regard to diameters, materials etc. The mechanically supporting structure shall be included. Elements that are only located at distributed positions in the arrester being modelled, such as holding plates, supporting rods or metallic spacers (see [Figure 9](#)), shall be present in the model. The active part shall have the same surrounding medium as in the real arrester. A dielectrically prorated section may also be a real arrester or arrester unit of the design.

**DIN:** Abbreviation for “Deutsches Institut für Normung e.V.”, a German organization for standardization based in Berlin.

**Direct molding:** a means of putting silicone rubber sheds on an arrester or on the FRP core of a →[composite hollow core insulator](#) or composite line insulator (as opposed to the →[push-on method](#)). In this case different technologies are utilized. Most frequently the body which is to be recast is set in a tightly closed lengthwise-divided mold, and completely recast in one pouring. This is possible and usual for lengths of up to about two meters. For even longer bodies the sheds are raised in several pourings, one after another, whereby each segment is →[vulcanized](#) to the previous one. The resulting encapsulation creates two lengthwise molding lines (frequently, but mistakenly, called “seams”). However, if this is carried out carefully, it does not negatively affect the operating behavior. In a different procedure the encapsulation is accomplished by raising the sheds one after another, by means of a one-piece form, which surrounds the body in a ring, and which is passed along the body step by step. Another known procedure is that in which the silicone rubber is raised spirally with a form which moves along the rotating body. The result is not single separate sheds, but instead one continuous spiral.

**Discharge voltage:** →[residual voltage](#)

**Disconnecter:** a device at the earth terminal of the arrester, which separates the arrester from the system after an overloading. This is especially important in conjunction with polymer-housed arresters, since their housing does not decay during a failure, and the puncture and flashover channels as well as black carbon and burn traces then form an earth fault (while a porcelain arrester often totally breaks apart, thereby becoming isolated from the line). Without a disconnecter – at least in a solidly earthed neutral system – a subsequent operation of the appropriate line section would no longer be possible. One disadvantage, however, is that after the disconnection of the arrester – which often goes unnoticed – protection against overvoltage is no longer feasible. Disconnecters are only installed in distribution systems or in association with →[line arresters](#). One of the most common working principles of disconnecters currently being manufactured is the ignition of a small explosive device (e.g., the cartridge of a gas pistol) caused by the thermal effect of the power-frequency earth fault current, which flows after an arrester failure. The explosive device tears the surrounding polymeric housing and causes the flexible earthing lead to disconnect from the arrester. These cartridges can however also be triggered by external heat, for example a warehouse fire. Consequently, handling, transport and storage of pyrotechnics are strictly regulated and require extensive approval procedures for end users and manufacturers. The regulations vary from country to country (see e.g. EU directive 2013/29/EU). That is why more and more disconnecters not containing any pyrotechnics are being used. From the outside they are indistinguishable from conventional disconnecters, the dimensions are practically identical, as can be seen in this example:

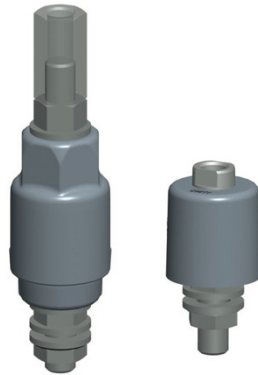

Disconnectors without pyrotechnics; left: for distribution arresters; right: for high-voltage line arresters

As also indicated in the picture, a distinction must further be made between disconnectors for distribution and for high-voltage line arresters, since very different requirements are placed on the trigger characteristics of both. Since Ed. 3.0 of IEC60099-4 a type test on the disconnectors is mandatory (IEC 60099-4 Ed. 3.0, 8.9).

**Distributed constant impulse generator:** generator to simulate the equivalent circuit of a line by distributed, series connected  $\rightarrow$  [\$\pi\$ -elements](#) (series inductors and shunt capacitors). In current impulse laboratories for arrester testing, according to the former IEC 60099-4 Ed. 2.2, distributed constant impulse generators were used for the  $\rightarrow$ [long-duration current impulse withstand test](#), the  $\rightarrow$ [line discharge test](#) and the  $\rightarrow$ [switching surge operating duty test](#). An example of a distributed constant impulse generator is given in the former IEC 60099-4 Ed. 2.2, Annex I. The generator had to be adjusted with great effort in such a way that the current amplitude and duration as well as its internal surge impedance met the requirements of the five different line discharge classes, for example. Distributed constant impulse generator generators are still used today, but the requirements for their adjustability have become significantly easier, since according to IEC 60099-4 Ed. 3.0 charge and energy may be introduced into the test specimens in almost any current impulse form.

**Distribution class arrester:**  $\rightarrow$ [arrester class](#)

**DL:**  $\rightarrow$ [arrester class](#) "distribution, low duty"

**DM:**  $\rightarrow$ [arrester class](#) "distribution, medium duty"

**Earth fault factor:** (symbol:  $k$ , according to IEC 60071-1) "at a given location, the ratio of the root-mean-square value of the highest power-frequency phase-to-earth voltage on a healthy phase during an earth fault, affecting one or more phases at any point on the system, to the root-mean-square value of the power-frequency phase-to-earth voltage which would be obtained at the given location in the absence of any such fault" (IEC 60071-1 Ed. 9.0, 3.15). The earth fault factor only refers to a particular point of a three-phase system, and to a particular system condition. The magnitude of the earth fault factor depends on the way the neutrals of a system are earthed:  $k \leq 1.4$  for a  $\rightarrow$ [solidly earthed neutral system](#), and  $k \geq 1.73$  for  $\rightarrow$ [resonant earthed](#) or  $\rightarrow$ [isolated neutral](#) systems.

**EGLA:** (externally gapped line arrester)  $\rightarrow$ [line arrester](#) with external serial spark gaps; the current relevant test standard is IEC 60099-8, which will, however, be replaced by IEC/IEEE 60099-11 in the near future.

**E-J-characteristic:**  $\rightarrow$ [field strength-current density characteristic](#)

**Electrical ageing:** (also: degradation) changes (or rather, deterioration) of the  $\rightarrow$ [voltage-current-characteristic](#) of an MO resistor or arrester in the  $\rightarrow$ [leakage current](#) region. With the level of technology used to manufacture MO resistors today, and under energy stress within the manufacturers' specified

limits, electrical ageing is not to be expected. It can, however, occur under conditions of extraordinarily high current impulse stress. Also, certain compounds in the gaseous atmosphere surrounding the MO resistors, or other solid or liquid insulating materials in direct contact with the resistors can, through chemical influences, cause electrical ageing, if no direct measures are undertaken to prevent this during development and production of the MO resistors and the arresters. Electrical ageing is partially reversible (the voltage-current-characteristic “recovers”). Electrical ageing may, however, also occur at the interfaces between the MO resistor column and a polymeric housing. If the bonding between the different materials is insufficient moisture may penetrate through the polymer into the boundary layer or into small cavities resulting from detachments and cause increased power losses. Many users are very concerned about electrical ageing and install [monitoring devices](#) that claim to be able to detect it. However, a much greater risk to arresters is insufficient sealing of their (porcelain as well as polymer type) housings, i.e. purely mechanical problems.

**Energy handling capability:** →[single impulse energy handling capability](#), →[thermal energy handling capability](#), →[line discharge class](#)

**Exponent  $m$ :** This exponent serves for atmospheric and altitude correction in IEC 60071-2. It takes into account the discharge behavior of the considered air gap. Details on this exponent can be found in IEC 60071-2, Ed. 5.0, Figure 10 and – far more – in its Annex H. In the arrester standard IEC 60099-4 Ed. 3.0, the exponent  $m$  is used to correct the required dielectric strength for arresters in [UHV](#) systems ( $U_s > 800$  kV) with the altitude of installation (see [Table 7](#) of this guide). For applications in systems with  $U_s \leq 800$  kV,  $m = 1$  is set for the sake of simplicity. In UHV applications, however, this would lead to excessive withstand voltage requirements, which is why reference is made there to Figure 10 of IEC 60071-2 in an adapted form. As shown here, derived from Figure 10, only curve “a” is used for the phase-to-earth insulation, and the abscissa does not show the coordination switching impulse withstand voltage  $U_{cw}$ , as actually in IEC 60071-2, but 1.1 times the switching impulse protection level SIPL of the arrester.

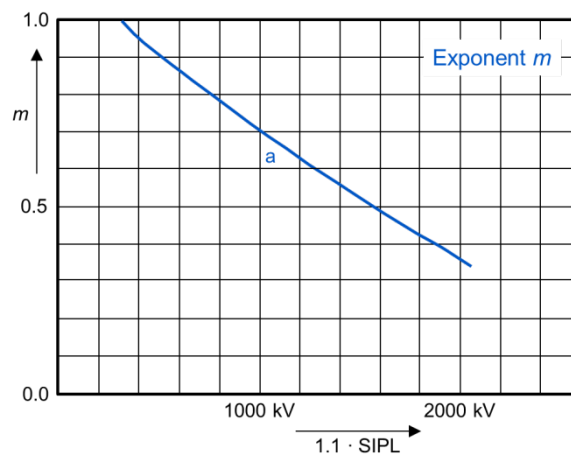

**Fast-front overvoltage:** (abbreviated: FFO); transient overvoltage, normally unidirectional, with time to peak of greater than  $0.1 \mu\text{s}$  up to and including  $20 \mu\text{s}$ , and tail duration below  $300 \mu\text{s}$  (IEC 60071-1 Ed. 9.0, 3.17.2.2).

**Fiber-glass reinforced plastic:** (abbreviated: FRP) this material is frequently utilized in an arrester for the MO resistor column supporting construction. In polymer-housed arresters it is the most important component for achieving the mechanical strength of the housing, e.g., in the form of rods, loops, tubes or wound mats.

**Field strength-current density characteristic:** (also:  $E$ - $J$ -characteristic) representation of the field strength (strictly speaking the voltage per unit height) of an MO resistor material in relation to the current density. Field strength peak values are generally applied to the ordinate. The abscissa uses current density peak values (only the resistive component in the case of power-frequency current densities), using logarithmic representation and covering a range of several decimal powers. It is

possible to multiply the field strength with the height, and the current density with the current cross-sectional area, to calculate the  $U-I$ -characteristic of an MO resistor type based on this material system.

**Flashover distance:** (also: arcing distance) The flashover distance of an insulator is the shortest distance between its metal end fittings (blue line in the left figure). See also → [creepage distance](#). Especially for arrester housings in the high-voltage system voltage levels, the influence of the grading rings must be taken into account, as they reduce the distance from the arrester top to ground. In the case of switching impulse voltage stress, it must also be regarded that flashovers may occur between the metal end fittings of the individual arrester units and the grading ring. Many individual flashover paths are to be considered, as shown in the figure on the right using a three-unit EHV arrester as an example. This is discussed in more detail in the Cigre Technical Brochure 696 (see: "Further Reading").

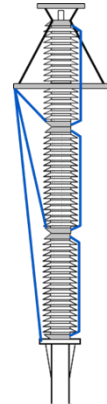
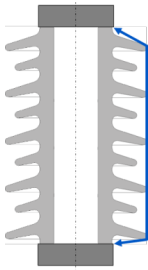

FRP: → [fiber-glass reinforced plastic](#)

**Gapped arrester:** This term describes very different concepts of surge arresters. Historically, it stood for an arrester having one or more internal gaps in series with one or more non-linear → [silicon-carbide](#) (SiC) resistors, standardized by the former IEC 60099-1, 2.2 (withdrawn in 1999). Today, there are also metal-oxide arresters with gaps on the market, internal (standard IEC 60099-6) as well as external ones (→ [EGLA](#), standard IEC 60099-8), and serial as well as shunt gaps (which are connected in parallel to part of the non-linear resistors). All these variants are not addressed in this handbook.

**GIS-arrester:** (precisely: gas-insulated metal enclosed surge arrester) a gas-insulated metal-enclosed metal-oxide surge arrester without any integrated series or parallel spark gaps, filled with an insulating gas other than air or with synthetic air under very high pressure; used in gas-insulated switchgear.

**Grading ring:** grading rings are used if the arrester length exceeds two meters, and usually for arresters made up of several units. They are arranged over approximately a quarter of the length of the arrester from the high-voltage flange towards the earth end, and serve to control the [voltage distribution](#) from the high-voltage end to the earth end, which is unfavorably influenced by the earth capacitances affecting the arrester. Without these countermeasures the MO resistors at the high-voltage end of the arrester would be stressed considerably more than those at the earthed end, leading to potentially excessive heating of the active part in this area. In suspended arresters, the grading rings are installed in various positions – for example the positions are different in an arrester installed on a cross arm or gantry and a → [line arrester](#) installed directly in the line, see the figure. Grading rings must not be confused with → [corona rings](#), which are only used to provide an electrostatic shield for the terminals at the high-voltage end in order to reduce the → [radio interference voltage](#).

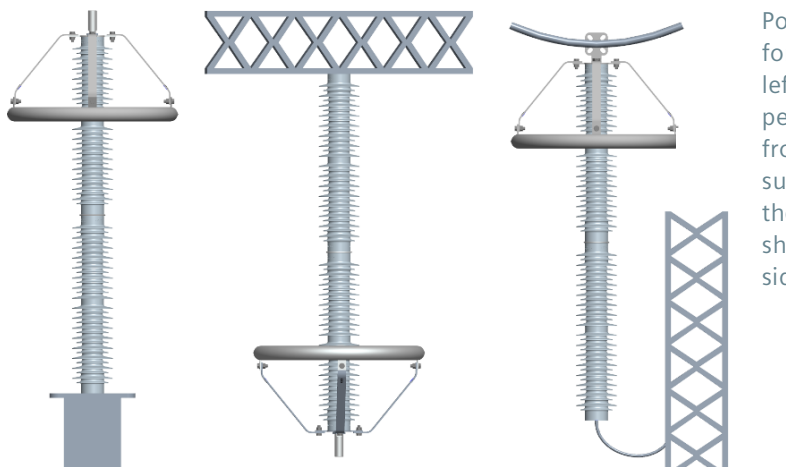

Position of the grading rings for different installations  
left: standing upright on a pedestal; middle: suspended from a crossarm; right: suspended in a line. Notice the orientation of the weather sheds whose upper (inclined) sides always show upwards.

**Guaranteed creepage distance:** creepage distance of an insulator as guaranteed by the manufacturer, taking into account possible dimensional tolerances which originate in the manufacturing process; normally a few percent less than the →[nominal creepage distance](#).

**High current impulse:** peak value of a →[current impulse](#) 4/10, used to test the stability of an arrester on nearby direct lightning strikes (IEC 60099-4 Ed. 3.0, 3.25). It should be noted, however, that a high current impulse with an amplitude of, for example, 100 kA, has little to do with a real lightning discharge current at the same value, which can last several ten to hundred microseconds. Especially while testing arresters with MO resistors of more than 48 mm in diameter, is the high impulse current then less an energy, and much more a dielectric stress because of the extraordinarily high →[residual voltage](#) (at least about 1.3 times higher than the [LIPL](#)) under the impact of this current. More precisely,

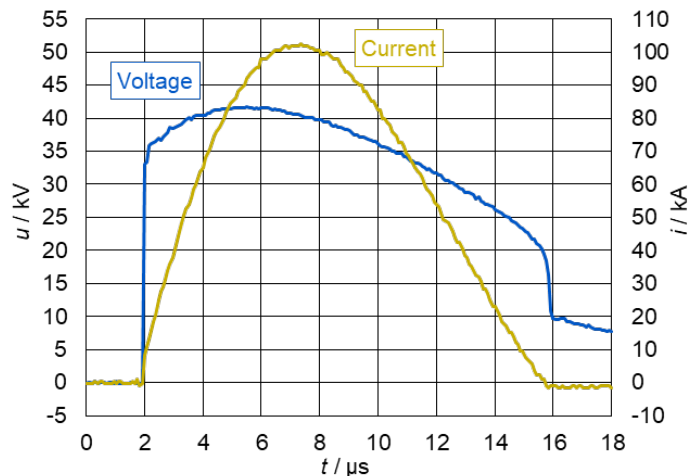

application of a high current impulse is the only way to dielectrically test the internal structure of an arrester when the MO resistors are inserted. High current impulse stress to an MO resistor is also practically the only way to produce noticeable [electrical ageing](#) (degradation of its [U-I-characteristic](#)) in the laboratory. High current impulses are, therefore, needed in the laboratory for the conditioning part of the →[operating duty tests](#) on arresters or →[arrester sections](#), as well as for the “test to verify the dielectric withstand of internal components” (IEC 60099-4 Ed. 3.0, 8.15). In the former IEC 60099-4 Ed. 2.2 high current impulses also served for energy injection into distribution arresters in the operating duty test. But this approach was abandoned, because the permissible time and amplitude tolerances of the high current impulse are far too big to achieve a particular specified amount of energy. High current impulses are produced by a capacitor discharge in an aperiodically damped RLC circuit. The current amplitude is within a range of 25 kA to 100 kA (see IEC 60099-4 Ed. 3.0, Table 4). The oscillogram illustrates an example of a high current impulse test on an arrester section at a current amplitude of 100 kA.

**High current impulse operating duty test:** this was a test in the former IEC 60099-4 Ed. 2.2, to be performed on distribution arresters and on the 20-kA High Lightning Duty arresters for the voltage range 1 kV to 52 kV. It had to be carried out on all arresters with →[nominal discharge current](#) of 1.5 kA, 2.5 kA or 5 kA and on arresters with nominal discharge current of 10 kA and →[line discharge class](#) 1. This test does not exist anymore in IEC 60099-4 Ed. 3.0.

**Highest system voltage:** →[highest voltage of a system](#)

**Highest voltage for equipment:** (symbol:  $U_m$ ) root-mean-square value of the highest phase-to-phase voltage for which the equipment is designed with reference to its insulation and other characteristics, which relate to this voltage in the relevant equipment standard (IEC 60071-1 Ed. 9.0, 3.10).

**Highest voltage of a system:** (symbol:  $U_s$ ) root-mean-square value of the highest phase-to-phase operating voltage, which occurs under normal operating conditions at any time and at any point in the system (IEC 60071-1 Ed. 9.0, 3.9).

**HTV silicone rubber:** High temperature vulcanizing silicone rubber. A single component type of →[silicone rubber](#), which is delivered in extremely high viscous conditions (comparable to natural rubber). It is injected into the mold under high pressures (several ten MPa) and temperatures (> 150 °C) and finally →[vulcanized](#) at similarly high temperatures.

**Hydrophobicity:** the characteristic of repelling water. No closed water film can form on a hydrophobic surface. Instead water on the surface pulls together to form single droplets and drips off the surface. According to a proposal of the Swedish Transmission Research Institute (“STRI guide 92/1: Hydrophobicity classification guide”), the degree of hydrophobicity was divided into seven classes (HC 1 to HC 7), where HC 1 corresponds to a completely hydrophobic and HC 7 to a completely hydrophilic (easily wetted) surface. This classification has been adopted by the IEC TS 62073 “Guidance on the measurement of wettability of insulator surfaces” (refer to this for further information on hydrophobicity). However, the hydrophobicity classes are referred to there as “WC” (for wettability class). An insulator material for which hydrophobicity is particularly characteristic is →[silicone rubber](#).

**IEC:** Abbreviation for “International Electrotechnical Commission”. Commission for the worldwide standardization in the area of electrotechnology, with headquarter in Geneva, Switzerland.

**IEEE:** Abbreviation for “Institute of Electrical and Electronics Engineers”, an American organization which, besides other tasks, develops standards on the field of electrical and information technology, based in New York City, USA.

**Impedance earthed neutral system:** a system in which one or more neutral points are earthed through an impedance to limit earth fault currents (IEC 60071-1 Ed. 9.0, 3.13).

$I_n$ : →[nominal discharge current](#)

**Inductance of an arrester:** MO resistors, when stressed by otherwise equal current amplitudes, exhibit increasing residual voltage with greater front steepness of the current impulse. Thus, in the case of →[steep current impulse](#) stress, a 5% increase in residual voltage is expected compared with that under equally high [lightning current impulse](#) stress. In addition, however, for very short rise times of the discharge current (front times of less than about 1  $\mu$ s) inductive voltage drops due to the spatial expansion of the arrester, must be taken into account. For outdoor arresters the inductance of a straight, stretched line with large clearance to other lines or earthed parts may be assumed. An arrangement like this has a specific inductance of about 1  $\mu$ H/m. At the same time, only 0.3  $\mu$ H/m is effective for a gas-insulated, metal-enclosed arrester because of its coaxial design. When viewing the protection level for steep current impulse stress in its entirety, the inductance of the connecting leads between overhead line conductor and arrester high-voltage terminal, as well as between its earthing terminal and effective station earth, must also be considered (see [Figure 7](#)).

**Insulation coordination:** the selection of the dielectric strength of equipment in relation to the voltages which can appear on the system for which the equipment is intended, while taking the service environment and the characteristics of the available overvoltage protective devices into account (IEC 60071-1 Ed. 9.0, 3.1).

**Insulating clamp:** an insulated clamp used in the medium-voltage system to fit arresters with disconnectors, failure current indicators or monitoring devices. Following an arrester failure, the insulating clamp must be able to withstand the line-to-earth voltage (the failed arrester is effectively a



short-circuit) until the arrester is replaced. The figure illustrates polymer-type insulating clamps. In the case of →[medium-voltage arresters with porcelain housing](#), metal clamps are often placed around the porcelain housing for this purpose, see the figure there.

**Internal partial discharge test:** This test proves that when a voltage of 1.05 times the →[continuous operating voltage](#) is applied, the arrester is sufficiently free of internal partial discharges. According to the currently applicable IEC 60099-4, Ed. 1.1, 1998-08, "sufficiently free" means a partial discharge level of  $\leq 10$  pC. The partial discharge test is part of the →[type tests](#), and is one of the most important →[routine tests](#). It is also defined as an →[acceptance test](#).

$I_s$ : →[rated short-circuit current](#)

**Isokeraunic line:** lines of equal →[keraunic levels](#) in a map on thunderstorm activities

**Isolated neutral system:** a system in which the neutral points are not intentionally earthed, except for high impedance connections for protection or measurement purposes (IEC 60071-1 Ed. 9.0, 3.11).

**Keraunic level:** (frequently, but mistakenly called isokeraunic level) the average number of thunderstorm days per year. From the keraunic level the ground flash density and consequently the expected arrester stress in the system can be deduced.

$K_s$ : →[safety factor  \$K\_s\$](#)

**Leakage current:** current which flows through the arrester at continuously applied power-frequency voltage. At alternating voltage it consists of a strongly capacitive and a considerably smaller resistive component, both of which depend on the MO resistors used. The capacitive part is heavily affected by stray capacitances and therefore also depends on the actual location of the arrester and on its overall dimensions. This is why the total leakage current is not a good indicator of possible electrical ageing, which would only increase the resistive part of the leakage current. Measuring only the resistive part is, however, very complex. The peak value of the leakage current, as measured on site, is usually within the range of 0.5 mA to 2 mA, depending on the type of MO resistors and the specific way of installation. An example is shown in [Figure 3](#).

**Leakage current monitor:** a device attached to the outside of the arrester (see picture), which measures the →[leakage current](#) flowing through the arrester. Usually the peak value of the current is recorded. Either the peak value itself or an apparent root-mean-square value over a scaling factor is indicated. Most leakage current indicators are combined with a →[surge counter](#) in the same housing

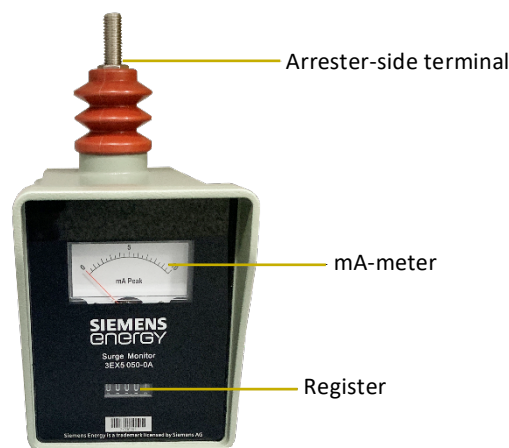

(see picture). Leakage current monitors are series-connected with the arrester in its earth connection. This requires installation of the arrester isolated from the ground by means of insulating feet (see [Figure 14](#)). Recent developments of leakage current monitors are based on the analysis of the third

harmonic in the leakage current, which is used to indirectly evaluate the resistive component (there is a relatively fixed relationship between the non-linear increase in the resistive component and the third harmonic in case of electrical ageing). Built-in electric field sensors compensate for the influence of the third harmonic in the voltage, which can seriously distort the measurement. The figure below shows such a system, powered locally using solar modules, which displays the leakage current digitally and also has a "traffic light function" ("OK" – "Warning" – "Alarm"). The readings can be sent over a wireless interface to a USB stick, from where they can be further analyzed and archived on a computer. For more information on arrester monitoring, see IEC 60099-5 Ed. 3.0, Annex D.



**Lightning current impulse:** → [current impulse](#) 8/20 with a → [front time](#) between 7  $\mu\text{s}$  and 9  $\mu\text{s}$  and a → [time to half-value on the tail](#) between 18  $\mu\text{s}$  and 22  $\mu\text{s}$  (IEC 60099-4 Ed. 3.0, 3.31). Lightning current impulses are used in the laboratory to ascertain the → [voltage-current-characteristic](#) of arresters, → [arrester sections](#) or → [MO resistors](#), as well as during the → [conditioning](#) as part of the → [operating duty test](#). In the case of distribution arresters, they are even used to transfer the rated thermal charge in the operating duty test. They are produced by a capacitor discharge in an aperiodically damped RLC circuit. The current amplitudes are within a range of 100 A to 40 kA. The oscillogram depicts an example of a residual voltage measurement on an MO resistor at a lightning current impulse of 10 kA.

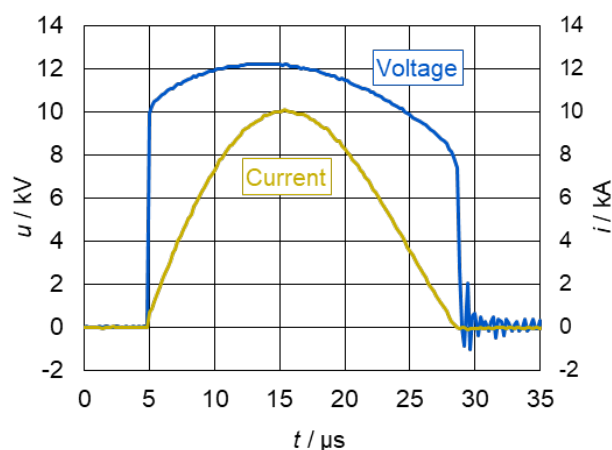

**Lightning impulse protection level:** (also: LIPL or  $U_{pi}$ ) maximum value of the → [residual voltage](#) of an arrester at → [nominal discharge current](#).

**Lightning impulse residual voltage:** → [residual voltage](#) of an arrester, → [arrester unit](#), → [arrester section](#) or → [MO resistor](#) at → [lightning current impulse](#).

**Lightning overvoltage:** transient overvoltage caused by a direct lightning strike to an overhead line conductor, a shield wire or a tower, or induced by lightning currents in neighboring lines or metal structures. Most of the lightning strikes (80% ... 90%) have a negative polarity. The currents are normally within the range of 30 kA to 50 kA, with measured maximum values of more than 300 kA. The front time is only a few microseconds, the total duration about 10  $\mu\text{s}$  to 100  $\mu\text{s}$ . Normally a lightning strike consists of multiple strokes, which occur at intervals of about 5 ms to 200 ms, using the same path as the initial stroke. The level of overvoltage caused by a lightning strike results from the lightning

current impulse flowing through the conductor and the →[surge impedance](#) of the line and amounts to several million volts. However when a flashover occurs across a line insulator, the level is actually limited to the value of the insulator flashover voltage. Only these overvoltages run into the substation and have to continue to be limited by the arresters installed there. Lightning overvoltages usually belong to the class of →[fast-front overvoltages](#), according to IEC 60071-1.

**Line arrester:** also: transmission line arrester (TLA) or transmission line surge arrester (TLSA); arrester which is installed in an overhead line in parallel to a line insulator to prevent flashovers of the insulator. Line arresters are preferably installed where frequent →[back flashovers](#) occur due to missing or inadequate overhead ground or shield wire protection and/or high tower footing impedances (e.g. in rocky terrain). In order to improve the supply quality of an already existing transmission or distribution line, installing line arresters on all, or only on some, of the towers or poles is in many cases a cost-saving alternative to improving the shielding of the line or the grounding of towers or poles. Line arresters are used not only in gapless technology, but also in conjunction with an external serial spark gap, which insulates the arrester from the line during normal operation, switching overvoltages and after overloading. The terms [NGLA](#) (non-gapped line arrester) and [EGLA](#) (externally gapped line arrester) are now in widespread use. Currently, NGLA are covered by the standard IEC 60099-4, and EGLA by IEC 60099-8. In the near future, all test requirements on line arresters (NGLA and EGLA, application on transmission and distribution lines) will be combined in the dual logo standard IEC/IEEE 60099-11, which is currently in preparation and expected to be published in 2024.

**Line discharge:** When an open-ended transmission line which has previously been charged to a certain overvoltage e.g. during de-energization by a circuit breaker, discharges, this will happen in the form of a traveling wave process. A rectangular-shaped current will develop, of an amplitude given by one half of the charge voltage divided by the surge impedance of the line and a duration of two times the propagation time of an overvoltage surge on the line. Example:  $U_s = 420$  kV, overvoltage of 2.5 p.u. corresponding to  $\hat{u} = 858$  kV, line length  $l = 300$  km,  $Z = 350 \Omega$ :

$$\rightarrow \hat{i} = \frac{\hat{u}}{2 \cdot Z} = \frac{858 \text{ kV}}{2 \cdot 350 \Omega} = 1.2 \text{ kA}, \quad \hat{t} = 2 \cdot \frac{l}{c_0} = 2 \cdot \frac{300 \text{ km}}{300 \text{ km/ms}} = 2 \text{ ms}$$

**Line discharge class:** The line discharge class was the only possibility in IEC 60099-4 up to Ed. 2.2 to specify the energy handling capability of an arrester. There were five line discharge classes (1 to 5) which are defined by increasing demands on the energy handling capability. They differ according to the testing parameters in the →[line discharge test](#) (IEC 60099-4, Ed. 2.2, Table 5). The →[thermal energy handling capability](#) of an arrester can be derived from its line discharge class in conjunction with the →[switching impulse residual voltage](#) (see IEC 60099-4, Ed. 2.2, Annex E, or IEC 60099-4 Ed. 3.0, Annex L). Also see [Figure 28](#) in Appendix 1 of this guide with the accompanying explanation.

**Line discharge test:** The line discharge test was a special form of the →[long-duration current impulse withstand test](#) up to the former IEC 60099-4 Ed. 2.2. In this test (IEC 60099-4, Ed. 2.2, 7.4.2), an arrester, an →[arrester section](#), or a single →[MO resistor](#) had to be exposed to 18 →[long-duration current impulses](#), which were in detail specified in IEC 60099-4, Ed. 2.2, Table 5. The test was considered passed if the resistors showed no evidence of puncture, flashover, cracking or other significant damage and their →[lightning impulse residual voltage](#) at →[nominal discharge current](#) had not changed by more than 5%.

**LIPL:** (also:  $U_{pl}$ ) →[lightning impulse protection level](#)

**LIWV:** abbreviation for →[standard rated lightning impulse withstand voltage](#) as defined in IEC 60071-1. Equivalent to →[BIL](#) in the American →[IEEE](#) standards.

**Long-duration current impulse:** → a rectangular current impulse, which quickly rises to its maximum value, remains substantially constant for a specified time period, and then quickly falls to zero. Characteristic parameters of a long-duration current impulse include polarity, peak value, virtual duration of the peak and virtual total duration (IEC 60099-4 Ed. 3.0, 3.35). Long-duration current impulses are needed in laboratories for the →[test to verify the repetitive charge transfer rating  \$Q\_r\$](#) , and the →[switching surge operating duty test](#) on individual →[MO resistors](#), →[arrester sections](#) or arresters.

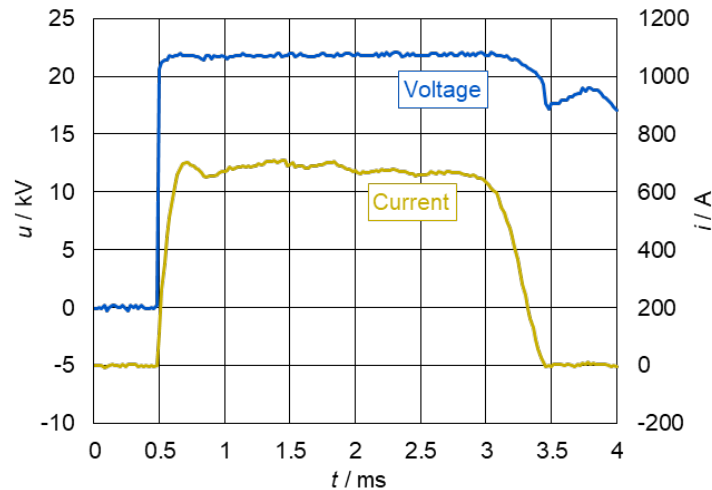

They are usually generated by the discharge of a →[distributed constant impulse generator](#), which is made up of capacitors and air-core inductors. The current impulses have peak values of up to 4 kA and virtual total durations of up to several milliseconds. The oscillogram depicts an example of a long-duration current impulse on an arrester section with a current peak value of about 700 A and a virtual duration of the peak of 2.4 ms.

**Long-duration current impulse withstand capability:** This is not a standard IEC 60099-4 term. It was, and maybe still is, however, listed by practically all the manufacturers, since it is a possible (but now obsolete) measure of the →[single impulse energy handling capability](#) (which was not defined in IEC 60099-4 before Ed. 3.0). The parameter that is relevant today to characterize the impulse energy handling capability is the [repetitive transfer rating  \$Q\_{rs}\$](#) . It was generally common to list the long-duration current impulse withstand capability as a maximum permitted →[long-duration current impulse](#) of a virtual duration of peak of 2 ms or 2.4 ms. At this current single MO resistors (typically three samples) were stressed eighteen or twenty times in succession following the test specification of the →[long-duration current impulse withstand test](#). The test was considered passed if the resistors showed no evidence of puncture, flashover, cracking or other significant damage and their →[lightning impulse residual voltage](#) at →[nominal discharge current](#) had not changed by more than 5%. However, since this test was never standardized, all manufacturers may have performed it differently – and may still do so.

**Long-duration current impulse withstand test:** This test, according to the former IEC 60099-4 Ed. 2.2, served – indirectly – as a proof of the →[single impulse energy handling capability](#). It has been replaced in IEC 60099-4 Ed. 3.0 by the [test to verify the repetitive charge transfer rating  \$Q\_r\$](#) . The test had to be carried out on individual MO resistors in open air according to the following diagram:

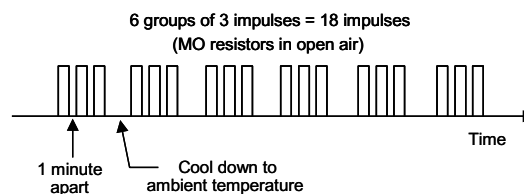

The test was considered passed if the resistors showed no evidence of puncture, flashover, cracking or other significant damage and their →[lightning impulse residual voltage](#) at →[nominal discharge current](#) had not changed by more than 5%.

**Low short-circuit current:** → [short-circuit tests](#)

**LR:** → [LSR](#)

**LSR:** (also known as LR) abbreviation for liquid silicone rubber. A type of silicone rubber which is delivered in a state of medium viscosity. It is mixed out of two components in more or less equal parts and can be filled into molds under moderate pressure at process temperatures ranging from 90 °C to 200 °C (however, in an arrester or insulator production a temperature of 140 °C is typically not exceeded in order to avoid damages to temperature sensitive components). LSR is increasingly replacing the widely used → [RTV silicone rubber](#), since it is more economical to purchase and process and has similarly good operating characteristics.

**MBL:** → [mean breaking load](#)

**MCOV:** (abbreviation for: maximum continuous operating voltage) a term which is only defined in the American arrester standard IEEE Std C62.11 as “the maximum designated root-mean-square (r.m.s.) value of power-frequency voltage that may be applied continuously between the terminals of the arrester”. Corresponds to the [continuous operating voltage](#)  $U_c$ , according to IEC 60099-4.

**Mean breaking load:** (MBL) mean breaking load for arresters with porcelain or cast resin housing, established in tests. See also → [mechanical loads](#).

**Mechanical loads:** static and dynamic loads are defined in IEC 60099-4, as shown in the figure. Whereas the indicated specifications are currently undisputed for porcelain housings, this is not the

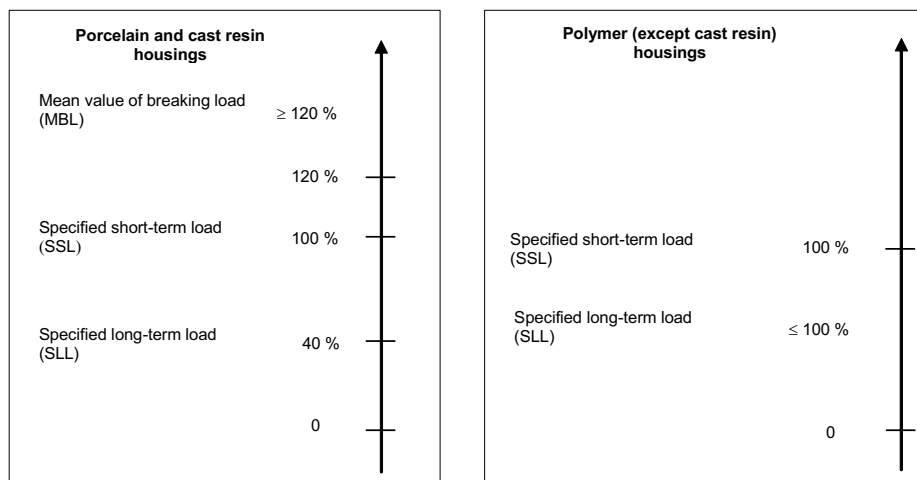

case for the various types of polymer-housed arresters, in which the active part is sometimes integrated with the housing and thus part of the mechanically supporting structure. At present, it is up to the manufacturer to decide how to specify the loads. IEC 60099-4 only defines how the specified loads are to be demonstrated in the type test. Cast resin housings resemble porcelain housings in terms of their mechanical properties (i.e. they are brittle), so they are treated in exactly the same way in the standard. → [specified long-term load](#) → [SLL](#) → [specified short-term load](#) → [SSL](#) → [mean breaking load](#).

**Medium-voltage arrester with porcelain housing:** manufacture of this type of arrester has virtually ceased, although large numbers are still in service. As shown in the diagram, they contain almost all the design features that are described in general terms in the section of this book covering arresters with porcelain housing. Low manufacturing costs are even more critical for medium-voltage arresters than for high-voltage arresters, but even so, the sealing system must meet the highest possible standards. The enormous cost pressure means that quality has not always been given top priority, and poor sealing is a common cause of failure in the medium-voltage range everywhere in the world – one of the reasons behind the drive to switch to polymer housings in the mid-1980s (although even leaving aside

sealing issues, medium-voltage arresters have significantly higher failure rates than high-voltage arresters because they are subject to more frequent energetic overload from lightning strikes close to the arrester). In principle, a medium-voltage arrester with porcelain housing has the same sealing system as a high-voltage arrester. The same principle is applied and the same materials are used, and

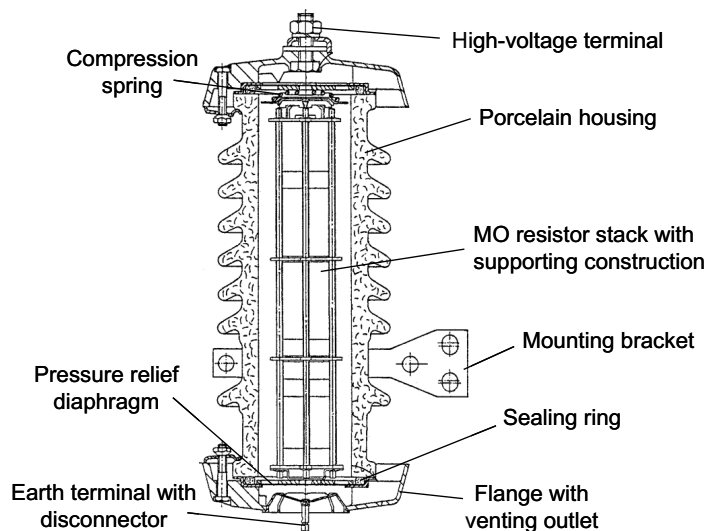

because the same pressure relief principle is used, the overload behavior is as described for high-voltage arresters. However there used to be many types of medium-voltage arrester with porcelain housing that lacked a pressure relief device – and some are still in service to this day. This was disputable even in those days and must now, finally, be characterized as outdated.

**Metal-oxide arrester:** (more precisely: metal-oxide surge arrester without gaps) an arrester with non-linear (voltage-dependent) → [metal-oxide resistors](#), which are connected in series or in parallel without any integrated series or parallel gaps (IEC 60099-4 Ed. 3.0, 3.38).

**Metal-oxide resistor:** (MO resistor) resistor with an extremely non-linear voltage-current-characteristic. All resistors currently designated as metal-oxide resistors consist of about 90% zinc-oxide (ZnO; consequently, the metal-oxide arrester is occasionally called a ZnO arrester). The other 10% is composed of about 10 different additives in the form of the oxides of rare earths (Bi, Sb, Co, Mn), which finally make up anywhere between a few ppm and up to a few percent of the total mass. The components are carefully milled into powder and mixed. A slurry is prepared from the powder, which is granulated and pressed into cylindrical (sometimes also toroidal) forms, dried and then sintered to a homogenous ceramic at temperatures of up to 1200 °C. The end faces are lapped or grinded, afterwards plated with aluminum or zinc, and finally the circumference is coated (e.g., glazed). The common dimensions of metal-oxide resistors currently being manufactured include diameters of between about 30 mm and 120 mm; the height is at the most ca. 45 mm. See [Figure 10](#) for a depiction.

**Metal-oxide surge arrester:** → [metal-oxide arrester](#)

**MO arrester:** → [metal-oxide arrester](#)

**MO resistor:** → [metal-oxide resistor](#)

**Monitoring spark gap:** a device which is attached to the outside of the arrester, whose removable control electrodes record, by means of sparkover marks, the number, intensity (amplitude and duration) and polarity of arrester operations. Monitoring spark gaps are series-connected with the arrester in its earth connection. This requires installation of the arrester isolated from the ground by means of insulating feet. The three pictures show a monitoring spark gap mounted on an arrester (top left), in opened condition with the control electrodes removed (top right), as well as examples of sparkover marks on the control electrodes (below). The real advantage of monitoring spark gaps was the possibility, in combination with gapped SiC arresters, of checking how often the arresters had sparked over (i.e. had to “operate”). The power-frequency follow-current of up to a few hundred amperes that flowed after the sparkover in the event of an overvoltage produced easily recognizable marks on the control electrodes. Even after the introduction of MO arresters without spark gaps, many users have stuck with this monitoring technique, even if the marks there are more difficult to interpret. Monitoring spark gaps are now largely considered outdated.

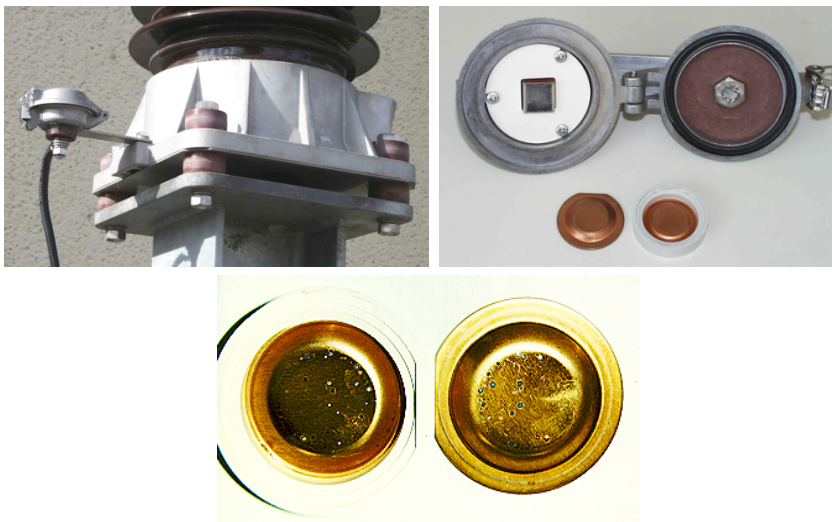

**MOSA:** → [metal-oxide arrester](#)

**Nearby direct lightning strike:** This term, in the arrester context, refers to lightning which directly strikes an overhead line conductor at a point which is so close to an arrester that an insulator flashover does not occur before the overvoltage surge – in the form of a traveling wave – reaches the arrester. This frequently happens in distribution systems and usually destroys the affected arrester. Arresters – particularly station arresters – are normally configured with the assumption that the greatest part of the contained charge in the lightning discharge is already diverted to ground by means of flashed over line insulators before it reaches the arrester.

**NEMA:** Abbreviation for “National Electrical Manufacturers Association”, an American organization for developing standards for the electrical manufacturing industry, based in Rosslyn, Virginia, USA.

**Neutral earthing of a system:** Power transmission and distribution systems, depending on how the neutral points are connected to earth (if at all), are categorized into → [isolated neutral systems](#), → [solidly earthed neutral systems](#), → [impedance earthed neutral systems](#) and → [resonant earthed neutral systems](#).

**NGLA:** non-gapped → [line arrester](#). Covered by the standard IEC 60099-4.

**Nominal creepage distance:** the creepage distance assigned to an insulator. The actual creepage distance may deviate by a few percent more or less, as a result of manufacturing tolerances. Also see → [guaranteed creepage distance](#).

**Nominal discharge current:** (symbol:  $I_n$ ) the peak value of a [lightning current impulse](#) which is, among others, used to classify an arrester. IEC 60099-4 Ed. 3.0 lists four different possible nominal discharge current values: 2.5 kA, 5 kA, 10 kA and 20 kA, see [Table 1](#). The [lightning impulse protection level](#) (LIPL,  $U_{pl}$ ) of an arrester is defined as the residual voltage when the nominal discharge current flows through it. The nominal discharge current thus has the function of a coordination current for which the lightning impulse protection level is defined in the process of [insulation coordination](#). The operating characteristics of an arrester, on the other hand, are not fully described by the nominal discharge current. Other parameters are more important and must be considered as well, such as the [repetitive charge transfer rating  \$Q\_{rs}\$](#) , the [thermal energy rating  \$W\_{th}\$](#) , or the [thermal charge transfer rating  \$Q\_{th}\$](#) .

**Nominal system voltage:** [nominal voltage of a system](#)

**Nominal voltage of a system:** a suitable approximate value of voltage used to designate or identify a system (IEC 60071-1 Ed. 9.0, 3.8). Also see [highest voltage of a system](#), [highest voltage for equipment](#).

**Normal service conditions:** According to IEC 60099-4 Ed. 3.0, 5.4.1, the following conditions are considered to be normal service conditions:

- Ambient air temperature within the range of - 40° C to + 40° C
- Solar radiation 1.1 kW/m<sup>2</sup>
- Altitude not exceeding 1000 m above sea level
- Frequency of the a.c. power supply not less than 48 Hz and not exceeding 62 Hz
- Power-frequency voltage applied continuously between the terminals of the arrester not exceeding the arrester's continuous operating voltage
- Wind velocity  $\leq$  34 m/s
- Vertical mounting of the arrester

Also see [abnormal service conditions](#).

**Operating duty test:** In the operating duty tests of IEC 60099-4 Ed. 3.0, 8.7, it is proved that after energy has been injected, the arrester remains [thermally stable](#) (i.e., cools back down to normal operating temperature) under the conditions of simultaneously occurring [temporary overvoltage](#). The test parameters are chosen to reflect worst case conditions with regard to possible [electrical ageing](#) (degradation) of the MO resistors and to the ambient and the operating temperature. The operating duty test may be carried out on [arrester sections](#), which represent the actual arrester with regard to the electrical and thermal behavior ([thermally equivalent prorated section](#)). Distinctions are made between the testing of [station class arresters](#) (injection of [rated thermal energy  \$W\_{th}\$](#) ) and [distribution class arresters](#) (transfer of [rated thermal charge  \$Q\_{th}\$](#) ). The test sequence for [station class](#) (SL, SM, SH) arresters is shown here:

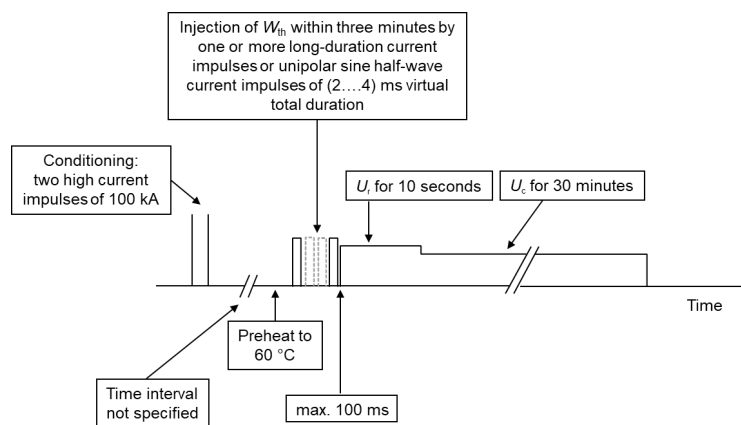

For [distribution class](#) (DL, DM, DH) arresters the test procedure looks different:

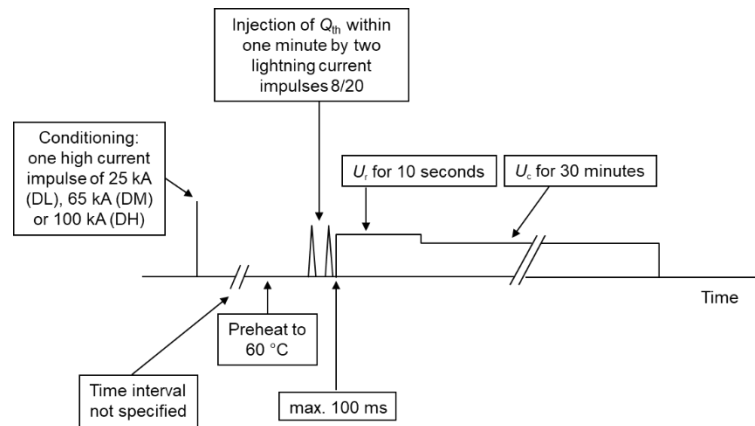

**Pi-element:** ( $\pi$ -element) A segment of an electrical equivalent circuit is designated as  $\pi$ -element when it is made up of one series element in the line and two parallel elements located in front of it and behind it, which are connected between the line and the ground reference (the red box in the diagram). When disregarding losses, a power transmission or distribution line can be represented as a series connection of  $\pi$ -elements, whose series elements consist of inductances and whose parallel elements consist of capacitances to earth, see diagram:

**Pollution level:** a measure of the degree of pollution to which resources at a location are subject. The pollution levels defined in IEC/TS 60815-1 Ed. 1.0 are shown in the table below. Depending on the

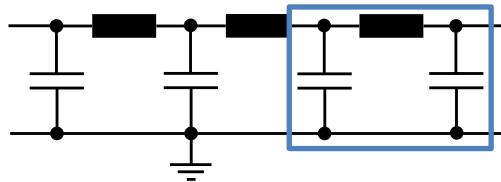

pollution level, IEC/TS 60815-2 (for porcelain and glass arresters) and IEC/TS 60815-3 (for polymer insulators) recommend the indicated  $\rightarrow$  [unified specific creepage distance](#) (USCD), but this must then be corrected for the particular insulator. For the sake of completeness, the converted values for the  $\rightarrow$  [specific creepage distance](#) (SCD) are also shown as defined in the previous version of the standard, IEC 60815 Ed. 1, 1986 (SCD and USCD values are, per definition, differing by the factor  $\sqrt{3}$ ). The pollution levels were also defined differently in the previous version: "I" – "light", "II" – "medium", "III" – "heavy", "IV" – "very heavy", and the recommendations for porcelain insulators were: "I" – SCD = 16 mm/kV; "II" – SCD = 20 mm/kV; "III" – SCD = 25 mm/kV; "IV" – SCD = 31 mm/kV.

**Pollution levels and recommendations according to IEC/TS 60815-1 Ed. 1.0**

Level	Definition	USCD mm/kV	(SCD) mm/kV
a	very light	22	12.7
b	light	27.8	16
c	medium	34.7	20
d	heavy	43.3	25
e	very heavy	53.7	31

**Portland cement:** a type of cement which is, for example, used to fix the metal end fittings and flanges of porcelain long-rod and hollow core insulators. Since corrosion appears when in contact with aluminum, an interface layer or coating (e.g., bitumen) must be applied before the embedding if aluminum flanges are used. This can be avoided by using →[sulfur cement](#).

**Power-frequency voltage versus time characteristic:** (also:  $U$ - $t$ -characteristic or  $V$ - $t$ -characteristic) representation of the dependency of applied permissible power-frequency voltage on permissible time duration. The voltage is referred to as the root-mean-square value related to the rated voltage. The time axis is logarithmically scaled and extends, for example, over a time range of 100 ms to 10 000 s. See [Figure 21](#) for an example. The standard IEC 60099-4 requires a type test on the power-frequency voltage versus time characteristic, and TOV values for the time range from 0.1 s to 3 600 s shall be displayed. The test shall be performed with and without prior duty. The TOV value “with prior duty” and 10 s time duration shall be *at least* equal to  $U_r$  according to the standard, but often manufacturers allow the application of rated voltage for times longer than ten seconds, as shown in this example:

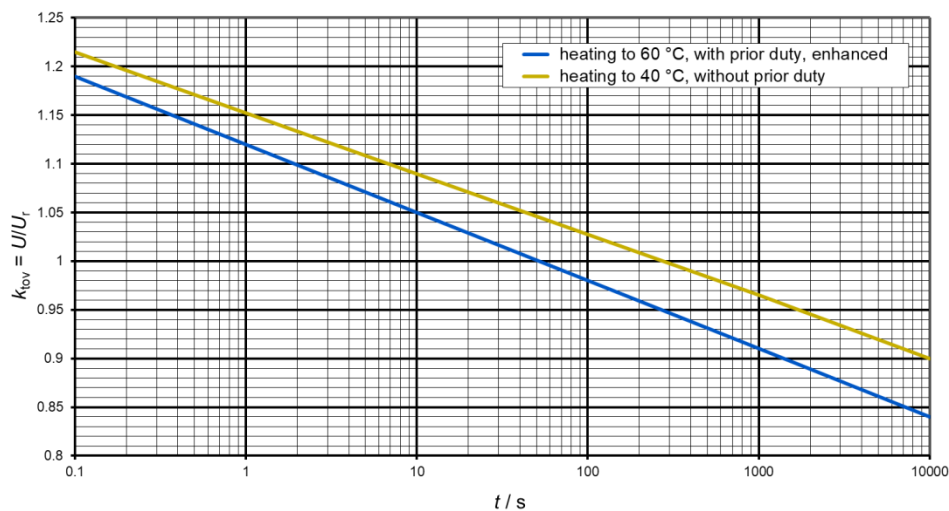

Also, although the IEC standard specifies that the rated voltage  $U_r$  be used as a reference value, many manufacturers present the curve in relation to the continuous operating voltage  $U_c$ . One reason for this is that the IEEE standards do not define a rated voltage at all. Curves of these different types of representation can easily be converted using the factor  $U_r/U_c = 1.25$ . The different appearances are shown below. In general, appropriate caution is required when working with TOV curves from different manufacturers.

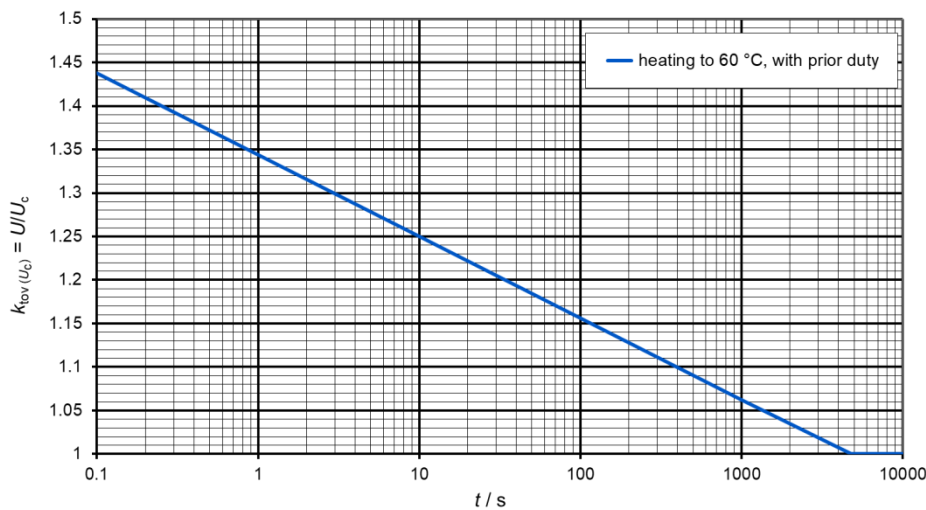
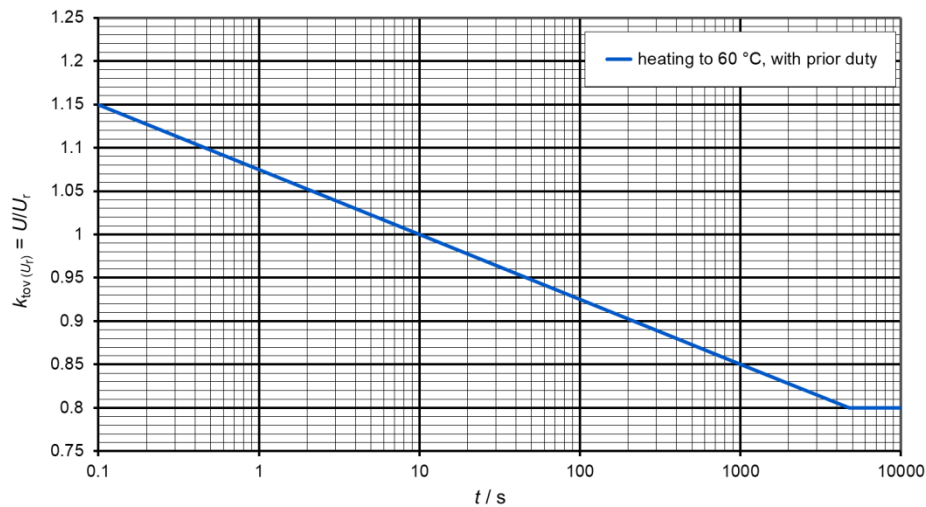

**Pressure relief class:** according to former editions of the standard IEC 60099-4 (for gapless MO arresters) and IEC 60099-1 (for gapped SiC arresters), the root-mean-square value of the symmetrical highest short-circuit current (given in kiloamperes, partly also in letters from A to D), which can flow after an arrester has been overloaded, without causing violent shattering of the housing. The pressure relief class has now been replaced by the →[rated short-circuit current](#). The short-circuit (or pressure relief) behavior is proved by means of the →[short-circuit tests](#) (formerly: pressure relief tests). Also see →[short-circuit withstand \(capability\)](#).

**Pressure relief tests:** →[short-circuit tests](#)

**Primer:** a chemical fluid, which is applied before →[silicone rubber](#) is molded onto other components, and which brings about a strong chemical bonding between the silicone rubber and any other material (aluminum, →[FRP](#), →[MO resistors](#)) after →[vulcanizing](#).

**Propagation rate** of a →[traveling wave](#): the propagation rate of an electro-magnetic wave on a line is

$$v = \frac{1}{\sqrt{\epsilon_r \cdot \mu_r}} \cdot \frac{1}{\sqrt{\epsilon_0 \cdot \mu_0}} = \frac{1}{\sqrt{\epsilon_r \cdot \mu_r}} \cdot c_0$$

where

- $\epsilon_r$  ... relative permittivity of the surrounding medium
- $\mu_r$  ... relative permeability of the surrounding medium
- $\epsilon_0$  ... vacuum permittivity,  $\epsilon_0 = 8.854 \cdot 10^{-12}$  F/m

$\mu_0$  ... vacuum permeability,  $\mu_0 = 4\pi \cdot 10^{-7}$  H/m  
 $c_0$  ... speed of light,  $c_0 \approx 3 \cdot 10^8$  m/s or 300 m/ $\mu$ s

This means that an electro-magnetic wave (traveling wave) in an overhead line ( $\epsilon_r = 1$ ,  $\mu_r = 1$ ) propagates at the speed of light ( $v = 300$  m/s), but in a cable, depending on its insulation ( $\epsilon_r = 2 \dots 4$ ,  $\mu_r = 1$ ), at (0.5...0.7) times the speed of light ( $v = 150 \dots 210$  m/s).

**Protection level of an arrester:** maximum value of the  $\rightarrow$ [residual voltage](#) of an arrester at a standard  $\rightarrow$ [current impulse](#). In this case there is a difference between the  $\rightarrow$ [lightning impulse protection level](#), the  $\rightarrow$ [switching impulse protection level](#) and the  $\rightarrow$ [steep current impulse protection level](#). Note: The terms "protection level" and "protective level" are used interchangeably in the arrester and insulation coordination standards and in the literature. In this handbook "protection level" is exclusively used.

**Protective level of an arrester:**  $\rightarrow$ [protection level of an arrester](#)

**Protective zone of an arrester:** (equivalent IEEE term: separation distance) An arrester generally has a limited protective zone of only a few meters to up to several ten meters, where the protective zone is defined as the maximum separation distance for which the insulation coordination requirements are fulfilled for a given  $\rightarrow$ [arrester protection level](#) and  $\rightarrow$ [coordination withstand voltage](#). Arresters, therefore, should be installed as close as possible to the device to be protected. Since  $\rightarrow$ [fast-front overvoltages](#) spread out over the line in the form of  $\rightarrow$ [traveling waves](#), the voltage at the terminals of the device to be protected can be considerably higher than the  $\rightarrow$ [residual voltage](#) of the assigned arrester. The arrester is "effective" only after a time interval, which depends on the propagation rate of the traveling wave and the distance, that is, the propagation time between the arrester and the device to be protected. The steepness of the overvoltage also has a decisive effect. Generally, the protection level and the location of the arrester must be coordinated in such a way that the  $\rightarrow$ [coordination withstand voltage](#) of the device to be protected is not exceeded. See IEC 60099-5, 60071-1 and 60071-2 for details on the procedure. The protective zone of an arrester, for the simple arrangement of a transformer connected to the end of a single feeder, can be estimated with the use of the following rule-of-thumb formula, but it must be noted that IEC 60071-2 recommends a statistical (quite complicated) approach rather than this simplified deterministic one:

$$x_s = \frac{\text{LIWV} - u_{pl}}{2 \cdot s} \cdot v$$

with  $x_s$  protective zone in m  
 LIWV standard lightning impulse withstand voltage of the device to be protected in kV  
 $u_{pl}$  lightning impulse protection level of the arrester in kV  
 $s$  front steepness of the lightning overvoltage in kV/ $\mu$ s (typical value: 1000 kV/ $\mu$ s)  
 $v$  propagation rate of a traveling wave in m/ $\mu$ s  
 (overhead line:  $v = c_0$  (velocity of light) = 300 m/ $\mu$ s;  
 cable:  $v \approx (150 \dots 210)$  m/ $\mu$ s)

Accordingly, when considering the connection of the equipment to an overhead line, this roughly results in a maximum protective zone of about 67 m for a solidly earthed 420 kV system (LIWV = 1425 kV,  $u_{pl} = 790$  kV), while for a 24 kV resonant earthed distribution system (LIWV = 125 kV,  $u_{pl} = 80$  kV), the protective zone is only slightly more than four meters! Also, see [Figure 5](#) with the accompanying example.

**Push-on method:** a method of equipping the  $\rightarrow$ [FRP](#) rods (when manufacturing composite long-rod line insulators) or FRP tubes (when manufacturing  $\rightarrow$ [composite hollow core insulators](#)) with  $\rightarrow$ [silicone rubber](#) sheds. Normally two procedures are common:

- 1) Onto the FRP core a smooth cover out of the same or a similar material as that of the sheds is molded, extruded or shrunken on. After that, pre-manufactured sheds are pushed on. The number of sheds and their distance to each other depends on the creepage path requirements.
- 2) Pre-assembled sheds are pushed directly onto the FRP core. There are no gaps between the sheds, instead they overlap at the ends like shingles.

By using →[primers](#), interlayers of →[RTV silicone rubber](#) and curing it afterwards in an oven, a bonding of the sheds to the core and to each other, respectively, is produced, which is nearly impossible to detach. Designs exist, however, in which the sheds are only pushed on in an expanded condition, and which only because of the mechanical strain remain attached to the core.

$Q_{rs}$ : →[repetitive charge transfer rating](#)

$Q_{th}$ : →[thermal charge transfer rating](#)

**Quartz porcelain:** a type of porcelain in accordance with subgroup “C 110: siliceous porcelains” of the standard IEC 60672-3.

**Radio interference voltage:** (RIV) a voltage, given in microvolts and measured using an interference voltage measuring receiver, caused by external electrical partial discharges (“corona”) at the arrester components at high potential (mainly the flange and connection at the high-potential end). Arresters for use on systems of  $U_s \geq 72.5$  kV must undergo a test to ensure that a radio interference voltage level of 2500  $\mu$ V is not exceeded for  $U = 1.05 \cdot U_c$  (IEC 60099-4 Ed. 3.0, 6.16.6 and 8.14). One way to reduce the radio interference voltage level is to use →[corona rings](#). Otherwise, the “usual” high-voltage optimizations must be carried out (avoiding sharp edges, increasing rounding radii, using electrostatic shielding effects).

**Ranges of highest voltage for equipment:** According to IEC 60071-1 the standard highest voltages for equipment  $U_m$  are categorized into two ranges:

- Range I:  $1 \text{ kV} \leq U_m \leq 245 \text{ kV}$
- Range II:  $U_m > 245 \text{ kV}$

At the insulation distances in “range I” only “streamer discharges” occur, characterized by pure impact ionization processes, whereas in “range II”, in the case of stress with switching impulse voltages, there are also “leader discharges”, characterized by thermo-ionization. Due to the peculiarities of leader growth, this means that insulation distances in “range II” have a pronounced minimum of dielectric strength when subjected to switching impulse voltage stress:

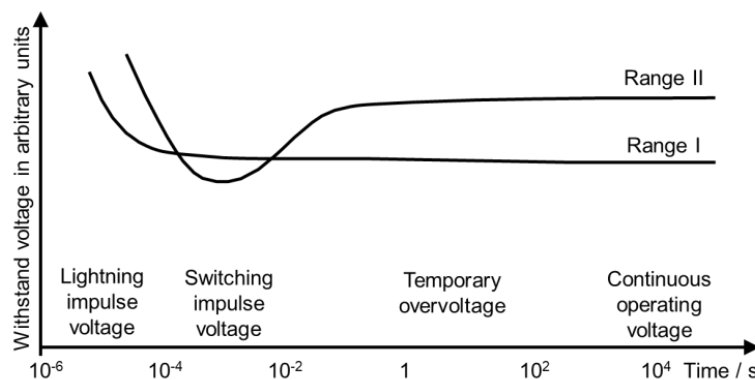

As a result, equipment in “range I” can be adequately characterized and qualified dielectrically by testing just with alternating and lightning impulse voltages, but tests with switching impulse voltages are mandatory for equipment in “range II” to cover the dielectric strength and to meet the minimum of the withstand voltage there.

**Rated short-circuit current:** (symbol:  $I_s$ ) the root-mean-square value of the symmetrical highest short-circuit current that can flow after an arrester has been overloaded, without causing violent shattering of the housing. Replaces the former →[pressure relief class](#) of the earlier editions of the IEC standard, 60099-4. This behavior is proved by means of the →[short-circuit tests](#) (formerly: pressure relief tests).

**Rated voltage of an arrester:** (symbol:  $U_r$ ) maximum permissible root-mean-square value of power-frequency voltage between the arrester terminals at which it is designed to operate correctly under → [temporary overvoltage](#) conditions as established in the → [operating duty tests](#). Normally, the manufacturer specifies whether it can be applied to the arrester for a duration of 10 seconds (which is the minimum requirement and corresponds to the value in the operating duty test) or for even longer durations, e.g. up to 100 seconds. The rated voltage is the reference parameter for determining the operating characteristics (IEC 60099-4 Ed. 3.0, 3.54).

**Rectangular current impulse:** → [long-duration current impulse](#)

**Reduced short-circuit current:** → [short-circuit tests](#)

**Reference current:** the peak value of a power-frequency current (in the case of asymmetrical current, the higher peak value of the two polarities), through which the → [reference voltage](#) is ascertained. The reference current is specified by the manufacturer for every MO resistor type, and can be found within a range of about 0.5 mA to 10 mA. It should be selected such that it is large enough for the peak value to clearly be caused by the resistive component in the leakage current, so that the reference voltage reading is not influenced by stray capacitances. An example of a reference voltage reading at reference current can be found under → [reference voltage](#).

**Reference voltage:** (symbol:  $U_{ref}$ ) the peak value of power-frequency voltage divided by  $\sqrt{2}$  between the arrester terminals while the → [reference current](#) is flowing. The reference voltage is used when choosing a test sample and determining the test parameters for the → [operating duty test](#). In the → [routine test](#) it serves as a simple, indirect proof that an arrester or an → [arrester unit](#) was assembled in accordance with the residual voltage requirements (the respective residual voltages and the reference voltages form, with only small variations, a fixed ratio). The following oscillogram gives an example of a reference voltage reading on an arrester unit during a routine test:

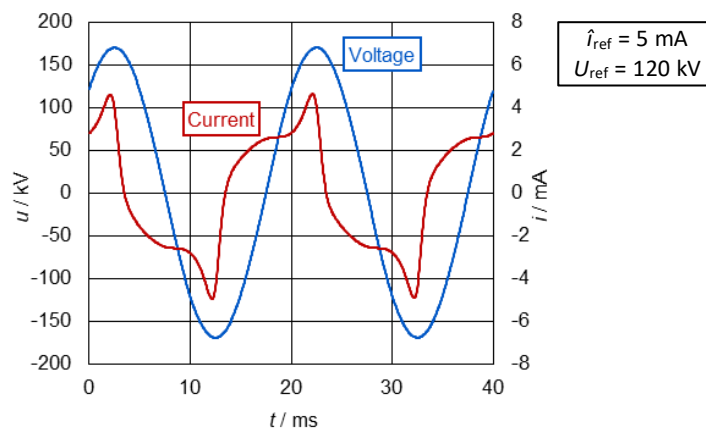

**Repetitive charge transfer rating:** (symbol:  $Q_{rs}$ ) maximum specified charge transfer capability of an arrester, in the form of a single event or group of surges that may be transferred through an arrester without causing mechanical failure or unacceptable electrical degradation to the MO resistors (IEC 60099-4 Ed. 3.0, 3.57). The charge is calculated as the absolute value of current integrated over time. "Single event or group of surges" is defined as lasting no longer than 2 s. It may be followed by a

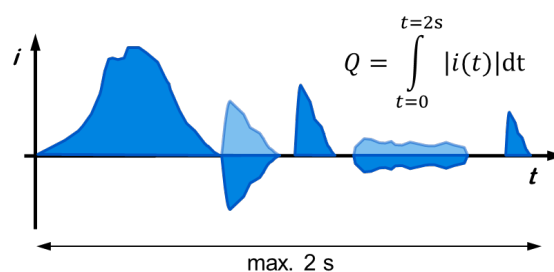

subsequent event at a time interval of not less than 60 s. The picture shows an arbitrary example to make this clear. For further details see →[test to verify the repetitive charge transfer rating](#).

**Required withstand voltage:** (symbol:  $U_{rw}$ ) a term from the →[insulation coordination](#): the test voltage that the insulation must withstand in a standard withstand test to ensure an acceptable failure rate (the so-called “performance criterion”) in actual service conditions. For an exact definition of the term and its meaning and determination during the process of insulation coordination, see IEC 60071-1 and 60071-2. Also see →[safety factor  \$K\_s\$](#) .

**Residual voltage:** the voltage drop between the terminals of the arrester when injecting a →[current impulse](#). For current impulses which have the shape and value of a standard test current impulse (→[lightning current impulse](#), →[switching current impulse](#), →[steep current impulse](#)), the simultaneously occurring residual voltages are the →[protection levels](#) which are assigned to this current shape and value.

**Resonant earthed (neutral) system:** a system, in which one or more neutral points are earthed through a reactance. As a result the capacitive component of a single-phase-to-earth fault is, for the most part, compensated (which is the reason that the term “compensated system” is also common). With resonant earthing, the residual current in a fault is limited to a value at which a burning arc in the air normally self-extinguishes (IEC 60071-1 Ed. 9.0, 3.14).

**RIV:** →[radio interference voltage](#)

**Routine tests:** According to IEC 60099-4 Ed. 3.0, 9.1, MO arresters without gaps must be subjected to at least the following routine tests:

- measurement of the →[reference voltage](#)
- →[residual voltage](#) test (on the complete arrester, →[arrester units](#) or samples comprising one or more →[MO resistors](#))
- →[internal partial discharge test](#)
- leakage check
- current sharing test (in case of multi-column arresters)
- check of the [disconnecter](#)

**RTV silicone rubber:** room temperature vulcanizing silicone rubber. A type of silicone rubber which is delivered in a state of low viscosity. It is mixed out of two components in greatly differing quantitative ratios and can be filled into molds without any pressure at process temperatures starting from room temperature. The →[vulcanizing](#), however, usually occurs at higher temperatures, in order to reduce the processing time. Increasingly being replaced by →[LSR](#) (or LR).

**Safety factor  $K_s$ :** a factor by which the →[coordination withstand voltage](#) must be multiplied, to obtain the →[required withstand voltage](#) of a device (and, consequently, its →[standard withstand voltage](#)). Stated simply, it is necessary to ensure that no voltage occurs on the terminals of the equipment, that is higher than its standard withstand voltages, divided by the safety factor,  $K_s$ . Arresters usually protect non-self-restoring insulations (an exception are, for example, →[line arresters](#)). In these cases  $K_s = 1.15$  applies. Thus, for example, to protect a transformer, which has a →[standard lightning impulse withstand voltage](#) of 1425 kV in a system with  $U_s = 420$  kV, the →[lightning impulse protection level](#) and the location of the arresters must be chosen, such that at the terminals of the transformer bushings a lightning overvoltage of  $1425 \text{ kV} / 1.15 = 1239 \text{ kV}$  is not exceeded. See IEC 60071-1 and 60071-2 for exact definitions of the terms mentioned and how they are determined and applied during the insulation coordination procedure.

**SCD:** →[specific creepage distance](#)

**Section of an arrester:** (also “prorated section”) a complete, suitably assembled part of an arrester which reproduces the behavior of the complete arrester with respect to a particular test. A section of an

arrester is not necessarily a → [unit of an arrester](#) (IEC 60099-4 ed. 3.0, 3.61). Examples for sections of an arrester are the → [thermally prorated section](#) or the → [dielectrically prorated section](#).

Separation distance: → [protective zone of an arrester](#)

SH: → [arrester class](#) "station, high duty"

Short-circuit current strength: → [short-circuit withstand \(capability\)](#)

Short-circuit rating: → [Short-circuit withstand \(capability\)](#)

**Short-circuit tests:** (previously: "pressure-relief tests") these tests prove, among other things, that the arrester housing is able to withstand short-circuit currents under specified test conditions without causing violent shattering of the housing (an unpressurized, non-explosive breaking is explicitly permitted, though). Testing must be carried out with the → [rated short-circuit current](#)  $I_s$  (duration of

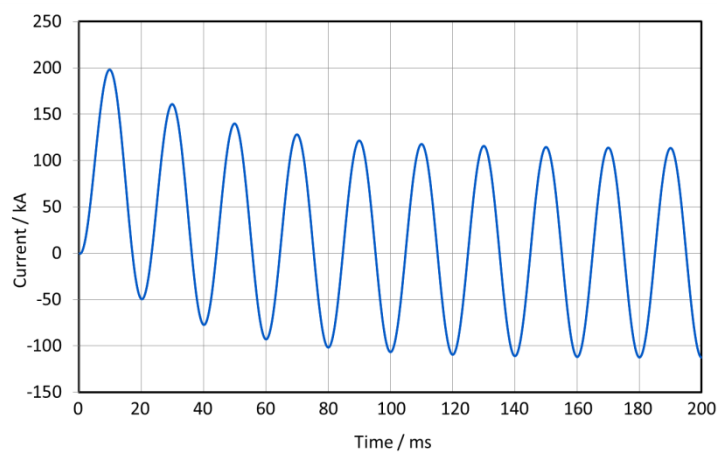

current flow 200 ms) and with two reduced short-circuit currents (duration also 200 ms) (approx. 50% and approx. 25% of  $I_s$ ), and with one low short-circuit current of  $600 \text{ A} \pm 200 \text{ A}$  (duration 1 s). The standardized currents are summarized in [Table 9](#). For the high (rated and reduced) currents, the test is performed on the longest unit of a type. The unit length for the low current is not specified. In arresters with an enclosed gas volume, the short-circuit is then initiated with an ignition wire and otherwise with a deliberate overload of the active part by applying a high voltage (in fact the difference between the arrester types for the short-circuit test is more complicated, see IEC 60099-4 Ed. 3.0, 8.10). In the first case, the current is overlaid with a decaying DC component, to reach the first peak value of 2.5 times the root-mean-square value, e.g., where  $I_{rms} = 80 \text{ kA}$ :  $\hat{i} = 200 \text{ kA}$ , as shown in the oscillogram. The test is passed if no parts weighing more than 60 g are found outside the (usually circular) area, as shown in the next figure. It is also a requirement that any open fire that occurs extinguishes itself within two minutes.

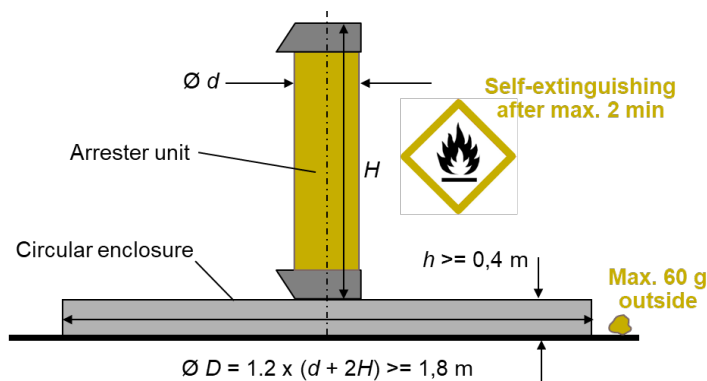

**Short-circuit withstand (capability):** ability of an arrester to withstand the short-circuit current that flows after an overload, without causing violent shattering of the housing. The short-circuit withstand capability used to be referred to as →[pressure relief class](#), and is now indicated as →[rated short-circuit current](#)  $I_s$ , and proved by means of →[short-circuit tests](#).

**SiC resistor:** →[silicon-carbide resistor](#)

**SIL:** abbreviation for “basic switching impulse insulation level”. Even though this term is frequently used when referring to →[IEC](#) standards, it is only defined by →[IEEE](#) and →[ANSI](#) (see standards IEEE Std 1313.1, IEEE Std C62.2, IEEE Std C62.22, ANSI C92.1). The IEC standard 60071-1 uses the term →[standard rated switching impulse withstand voltage](#) →[SIWV](#) instead.

**Silicon-carbide resistor:** (SiC resistor) non-linear resistor, which was used in the arresters before the introduction of →[metal-oxide resistors](#). The non-linearity of its →[voltage-current-characteristic](#) is considerably less pronounced than in a metal-oxide resistor. Thus arresters with silicon-carbide resistors need serial spark gaps, which separate the arrester from the line during continuous operation, and which interrupt the power-frequency follow current that flows through the arrester after a discharge operation.

**Silicone rubber:** (correct chemical short form: SI, or, depending on the particular type: MQ, VMQ, PMQ, PVMQ; in the literature frequently: SIR). The basic Si-O-Si-O structure with its attached methyl groups (CH<sub>3</sub>) is characteristic of silicone rubber:

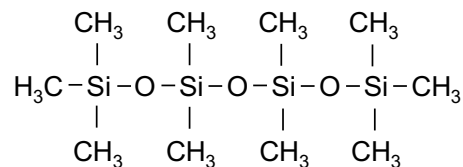

Fillers, such as aluminum trihydrate (ATH) or special additives, affect the tracking and erosion resistance which is needed in high-voltage applications. Not only does silicone rubber provide such important advantages as high elasticity and tear resistance, high temperature resistance (trouble-free application within the temperature range of -45 °C to +180 °C), flame retardant properties (if burning does occur, only silica acid remains) and high electric breakdown field strength, but also the most notable property of silicone rubber, its →[hydrophobicity](#): water simply drips off the silicone surface. This property also transfers to pollution layer films, in that the silicone rubber insulator is water repellent even in heavily polluted conditions, and thus lends the associated devices especially good operating characteristics in polluted environments. The hydrophobicity can indeed decrease when exposed to the long-term effects of moisture or to electric discharge activities; however, after these conditions discontinue, the original water-repellent properties return within a short time (in a few hours or days) – a mechanism, whose effect, as far as is presently known, is interminable. Silicone rubber is processed into three different basic forms: →[HTV silicone rubber](#), →[RTV silicone rubber](#) and →[LSR or LR](#).

**Single impulse energy handling capability:** the maximum absorbable energy of an arrester during a single discharge operation that can be injected several times (at least 20 times) during an arrester’s service life. Besides some other influencing factors, it is mainly limited by the maximum allowable thermo-mechanical stress on the ceramic of the MO resistors. If this energy value is exceeded thermo-mechanical breaking, puncturing, or flashover of the MO resistors may occur (see picture). Up to



IEC 60099-4 Ed. 2.2, the energy handling capability was only defined by the →[line discharge class](#). With IEC 60099-4 Ed. 3.0 new energy handling definitions have been introduced. The single energy handling capability is now specified by the →[repetitive charge transfer rating](#) ( $Q_{rs}$ ). The single impulse energy handling capability is smaller than the →[thermal energy handling capability](#).

**SIPL:** also:  $U_{ps}$  →[switching impulse protection level](#)

**SIR:** →[silicone rubber](#)

**SIWV:** abbreviation for “[standard rated switching impulse withstand voltage](#)” as specified in IEC 60071-1. Equivalent to →[SIL](#) in the American IEEE standards.

**SL:** →[arrester class](#) “station, low duty”

**SLL:** specified long-term load. It is defined in IEC 60099-4 as a force perpendicular to the longitudinal axis of an arrester, allowed to be applied during service for long periods without causing any mechanical damage to the arrester. Compare →[SSL](#). See also →[mechanical loads](#).

**Slow-front overvoltage:** (abbreviated: SFO); transient overvoltage, normally unidirectional, with times to peak of 20  $\mu$ s up to 5000  $\mu$ s and →[times to half-value on the tail](#) of not more than 20 ms (IEC 60071-1 Ed. 9.0, 3.17.2.1).

**SM:** →[arrester class](#) “station, medium duty”

**Solidly earthed neutral system:** a system within which one or more transformer neutral points are directly connected to the earth (IEC 60071-1 Ed. 9.0, 3.12)

**Specific creepage distance:** (SCD) →[creepage distance](#) of an insulator in relation to the →[highest voltage for equipment](#),  $U_m$  (phase-to-phase voltage!), given in mm/kV. For example, an insulator with a creepage distance of 10 500 mm for use in a 420 kV system has a specific creepage distance of 25 mm/kV. IEC 60815, Ed. 1 of 1986 referred to the specific creepage distance. The new series IEC 60815-1, -2 and -3, which was published in 2008, defines and specifies the →[unified specific creepage distance](#), which uses the phase-to-earth voltage instead of the phase-to-phase voltage. According to this definition the example arrester has a *unified* specific creepage distance of 43.3 mm/kV. The specific creepage distance is selected on the basis of the relevant →[pollution level](#).

**Specified long-term load:** →[SLL](#)

**Specified short-term load:** →[SSL](#)

**SSL:** specified short-term load. It is defined in IEC 60099-4 as a force perpendicular to the longitudinal axis of an arrester, allowed to be applied during service for short periods and for relatively rare events (for example, short-circuit current loads, very high wind loads or seismic loads) without causing any mechanical damage to the arrester. For seismic loads an even higher load than the SSL may be considered. Compare →[SLL](#). See also →[mechanical loads](#).

**Standard lightning impulse (voltage):** a standard test voltage defined in IEC 60060-1, used to prove that the insulation can withstand the stress imposed by →[fast-front overvoltages](#). The standard lightning impulse 1.2/50 has a front time of 1.2  $\mu$ s and a →[time to half-value on the tail](#) of 50  $\mu$ s. The following two oscillograms show the standard lightning impulse in two different time resolutions:

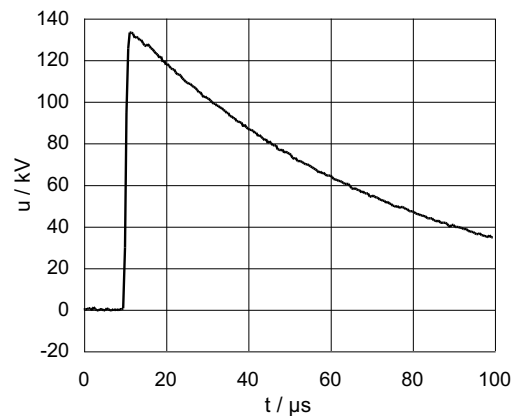
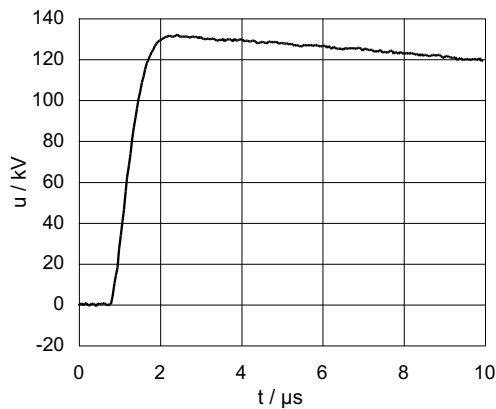

**Standard nominal discharge current:** (symbol:  $I_n$ ) In Ed. 3.0 of IEC 60099-4 four nominal discharge current amplitudes are listed as standard values: 20 kA, 10 kA, 5 kA and 2.5 kA. Until Ed. 2.2 of the standard a value of 1.5 kA could also be used.

**Standard rated lightning impulse withstand voltage:** ( $\rightarrow$ LIWV also known in American standards as  $\rightarrow$ BIL for "basic lightning impulse insulation level") a standard value of a lightning impulse test voltage, which is used in a standard withstand test to prove that the insulation complies with the required withstand voltage. The different standard lightning impulse withstand voltage values associated with the  $\rightarrow$ highest voltage for equipment,  $U_m$ , are found in IEC 60071-1 Ed. 9.0, Tables 2 and 3.

**Standard switching impulse (voltage):** a standard test voltage defined in IEC 60060-1 used to prove that the insulation can withstand the stress imposed by  $\rightarrow$ slow-front overvoltages. The standard switching impulse 250/2500 has a front time of 250  $\mu$ s and a  $\rightarrow$ time to half-value on the tail of 2500  $\mu$ s. The two oscillograms show the standard switching impulse in two different time resolutions:

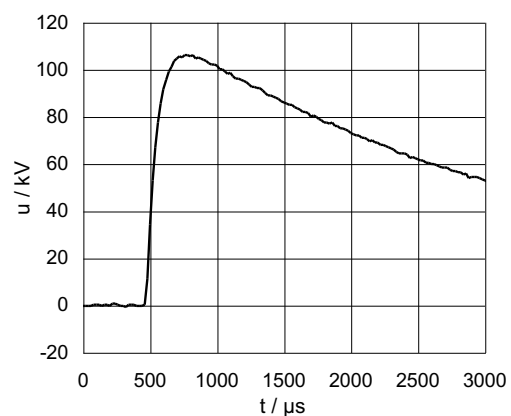
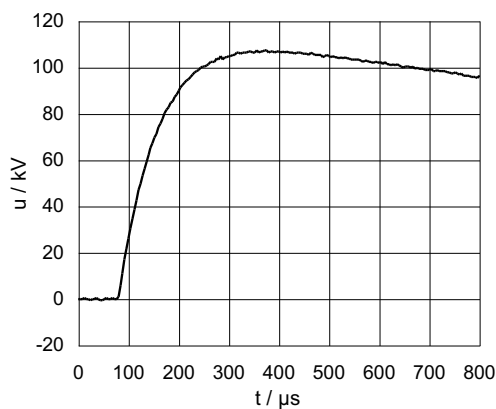

**Standard rated switching impulse withstand voltage:** ( $\rightarrow$ SIWV: also known in American standards as  $\rightarrow$ SIL for "basic switching impulse insulation level") a standard value of a switching impulse test voltage, which is used in a standard withstand test to prove that the insulation complies with the required withstand voltage. According to IEC 60071-1, standard switching impulse withstand voltages are only specified for  $\rightarrow$ range II, that is voltage levels of  $U_m > 245$  kV. The different standard switching impulse withstand voltage values associated with the  $\rightarrow$ highest voltage for equipment,  $U_m$ , are found in IEC 60071-1 Ed. 9.0, Table 3.

**Standard withstand voltage:** (symbol:  $U_w$ ) a term from the  $\rightarrow$ insulation coordination: the standard value of the test voltage applied in a standard withstand test. For an exact definition of the term and its meaning and determination during the process of insulation coordination, see IEC 60071-1 and 60071-2. Also see  $\rightarrow$ safety factor  $K_s$ .

**Station class arrester:** → [arrester class](#)

**Steep current impulse:** → [current impulse](#) with a → [front time](#) between 0.9  $\mu\text{s}$  and 1.1  $\mu\text{s}$  and a → [time to half-value on the tail](#) of not more than 20  $\mu\text{s}$  (IEC 60099-4 Ed. 3.0, 3.66). Steep current impulses are used in the laboratory to ascertain the → [voltage-current-characteristic](#) of arresters, → [arrester sections](#)

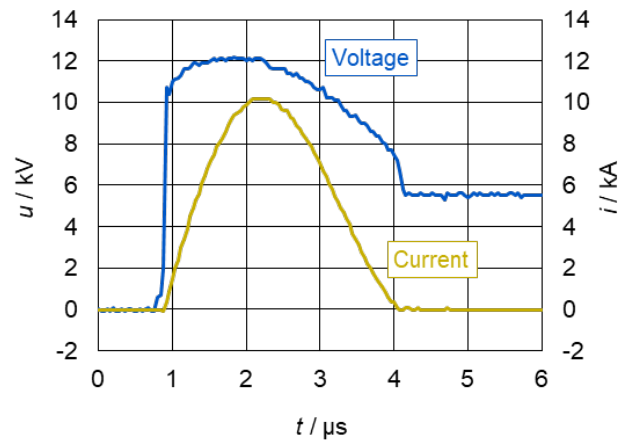

or → [MO resistors](#). They are produced in a low-inductance, frequently coaxial test setup by a practically undamped capacitor discharge into the test sample. The current amplitudes are within a range of 1.5 kA to 20 kA. The oscillogram depicts an example of a residual voltage measurement on an MO resistor at a steep current impulse of 10 kA.

**Steep current impulse protection level:** maximum value of the → [residual voltage](#) of an arrester at a → [steep current impulse](#) of the same peak value as the → [nominal discharge current](#).

**Sulfur cement:** a type of cement which, for example, is used to cement metal flanges on porcelain insulators. Sulfur cement consists of about 65% highly pure sulfur and about 35% mineral fillers. It is poured at temperatures of about 140 °C and begins to set when the temperature falls below 120 °C. The advantage of sulfur cement over → [Portland cement](#), is, among others, its trouble-free contact with aluminum. The disadvantage is the loss of strength which begins to occur at temperatures above 90 °C. Since these temperatures are not achieved in arrester flanges, sulfur cement is frequently used for arresters.

**Surge counter:** a device externally fixed to the arrester (see picture below), which has an electromechanical or electronic register to record the number of arrester operations. The surge counter is series-connected with the arrester in its earth connection. This requires installation of the arrester isolated from the ground by means of insulating feet. See also → [leakage current monitor](#) and [Figure 14](#).



**Surge impedance:** impedance relevant for traveling wave processes on a line. Ignoring the resistive components (i.e. assuming a lossless line), the surge impedance results from the inductance and the capacitance per unit length of the line as:

$$Z = \sqrt{\frac{L'}{C'}}$$

with

$Z$	surge impedance in $\Omega$
$L'$	inductance per unit length in H/m
$C'$	capacitance per unit length in F/m

From the equation above it is clear that the surge impedance is not dependent upon the length, that is, it is the same on every location on the line. For high-voltage transmission lines its value is between about 300  $\Omega$  ( $U_s > 800$  kV) and 450  $\Omega$  ( $U_s < 245$  kV) (see IEC 60099-5 Ed. 3.0, Table I.2).

**Switching current impulse:** peak value of a  $\rightarrow$ [current impulse](#) with a  $\rightarrow$ [front time](#) of between 30  $\mu\text{s}$  and 100  $\mu\text{s}$  and a  $\rightarrow$ [time to half-value on the tail](#) of roughly double the front time (IEC 60099-4 Ed. 3.0, 3.68). Switching current impulses are used in the laboratory to ascertain the  $\rightarrow$ [voltage-current-](#)

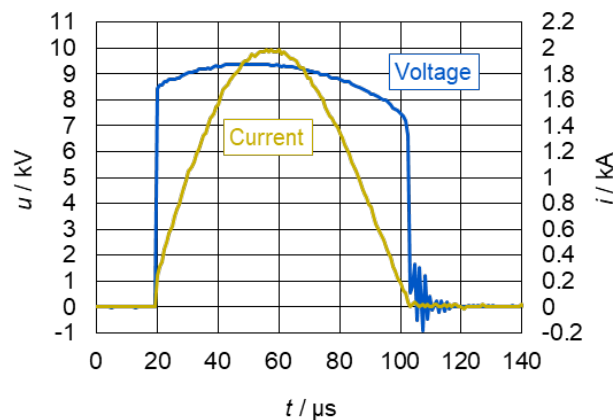

[characteristic](#) of arresters,  $\rightarrow$ [arrester sections](#) or  $\rightarrow$ [MO resistors](#). They are produced by a capacitor discharge in an aperiodically damped RLC circuit. The current amplitudes are within a range of 125 A to 2 kA. The oscillogram depicts an example of a residual voltage measurement on an MO resistor at a switching current impulse of 2 kA.

**Switching impulse discharge current:** amplitude of a  $\rightarrow$ [switching current impulse](#) specified for a specific  $\rightarrow$ [arrester class](#). The current impulse amplitudes have peak values of 0.5 kA, 5 kA, 10 kA or 20 kA (IEC 60099-4 Ed. 3.0, Table 1).

**Switching impulse protection level:** (also SIPL or  $U_{ps}$ ) maximum value of an arrester's  $\rightarrow$ [residual voltage](#) at the  $\rightarrow$ [switching impulse discharge current](#) specified for its class.

**Switching impulse residual voltage:**  $\rightarrow$ [residual voltage](#) of the arrester at  $\rightarrow$ [switching current impulse](#).

**Switching overvoltage:** transient overvoltage caused by transient phenomena as a result of switching operations or system failures (earth faults, inductive or capacitive switching, load rejection, ferroresonance, etc.). The frequency is within a range of 100 Hz to 10 kHz, and front times occur in the order of magnitude of 30  $\mu\text{s}$  to 3000  $\mu\text{s}$ . The voltage amplitudes can take on between 2 p.u. and 3 p.u. ( $1 \text{ p.u.} = \sqrt{2} \cdot U_s / \sqrt{3}$ ), depending on the system voltage. Switching overvoltages usually belong to the class of  $\rightarrow$ [slow-front overvoltages](#), according to IEC 60071-1.

**Switching surge operating duty test:** This test was defined in the former IEC 60099-4 up to Ed. 2.2 and had to be carried out on 10-kA-arresters of  $\rightarrow$ [line discharge classes](#) 2 and 3, as well as on 20-kA-

arresters of line discharge classes 4 and 5. The sequence is schematically depicted in the following diagram:

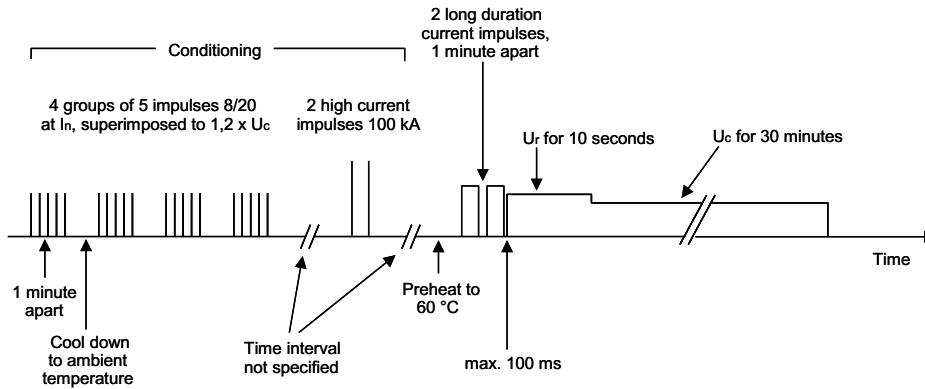

The test has been replaced by the [operating duty tests](#) in IEC 60099-4 Ed. 3.0.

**System voltage levels:** Depending on the highest voltage of the system,  $U_s$ , three-phase electric power systems are distinguished as follows:

- Medium voltage (MV):  $U_s \leq 52\text{ kV}$
- High voltage (HV):  $52\text{ kV} < U_s \leq 245\text{ kV}$
- Extra high voltage (EHV):  $245\text{ kV} < U_s \leq 800\text{ kV}$
- Ultra high voltage (UHV):  $U_s > 800\text{ kV}$

**Temporary overvoltage:** (abbreviation: TOV) power-frequency overvoltage which can occur for a duration of several tenths of a second to up to a few seconds, as a result of a switching operation or system failure. Its value depends on the type of [neutral earthing](#) in the system. A special case would involve [resonant earthed](#) and [isolated neutral](#) systems, in which the phase-to-earth voltage of the healthy phases takes on the value of the phase-to-phase voltage, in case of an earth fault. This operating condition can last for a long time (up to several hours).

**Tests:** [→type tests](#), [→routine tests](#), [→acceptance tests](#)

**Test to verify the repetitive charge transfer rating  $Q_{rs}$ :** The repetitive charge transfer rating is a feature of the used MO resistors in an arrester and can be verified only on individual MO resistor samples. For this reason the test has to be carried out with a charge of 1.1 times  $Q_r$ , since the failure probability of a complete arrester is higher than that of the individual MO resistors contained in it. Example: for use in an arrester with  $Q_{rs} = 1.6\text{ C}$  the MO resistors have to be tested with  $Q_{\text{rest}} = 1.76\text{ C}$ . The test is to be carried out on at least ten samples and consists of twenty charge transfers per sample. In contrast to the previous [long-duration current impulse withstand test](#) (up to IEC 60099-4 Ed. 2.2), where no failure of a sample was allowed and therefore no failure probability could be derived, one sample out of ten or two samples out of twenty are allowed to fail. Thus, a failure probability of not more than 0.56% can be claimed (see IEC 60099-4 Ed. 3, 8.5.3, NOTE 1).

**Thermal charge transfer rating:** (symbol:  $Q_{th}$ ) maximum specified charge that may be transferred through an arrester or arrester section within three minutes in a thermal recovery test without causing a thermal runaway (IEC 60099-4 Ed. 3.0, 3.72)

**Thermal energy handling capability:** maximum amount of energy that can be absorbed by an arrester in the form of several subsequent discharges within a short time interval, without leading to [thermal instability](#) (see also [Figure 8](#)). It is greater than the [single impulse energy handling capability](#). Up to IEC 60099-4 Ed. 2.2, the energy handling capability was only defined by the [line discharge class](#). With IEC 60099-4 Ed. 3.0 new energy handling definitions have been introduced. The thermal energy

handling capability is now specified by the →[thermal energy rating](#) ( $W_{th}$ ) for station class arresters and by the →[thermal charge transfer rating](#) ( $Q_{th}$ ) for distribution class arresters. →[arrester class](#)

**Thermal energy rating:** (symbol:  $W_{th}$ ) maximum specified energy, given in kJ/kV of  $U_r$ , that may be injected into an arrester or arrester section within 3 minutes in a thermal recovery test without causing a thermal runaway (IEC 60099-4 Ed. 3.0, 3.73)

**Thermally prorated section:** (also known as “thermal equivalent”) a →[section of an arrester](#) used in the →[operating duty test](#), which reproduces the thermal behavior of a complete arrester. In principle, a thermally equivalent prorated section is a cutout of the original arrester, whose terminals are so well thermally insulated that the heat is mostly dissipated radially (as it is the case with the real arrester). The picture shows an example, which represents a porcelain housed high-voltage arrester. A problem

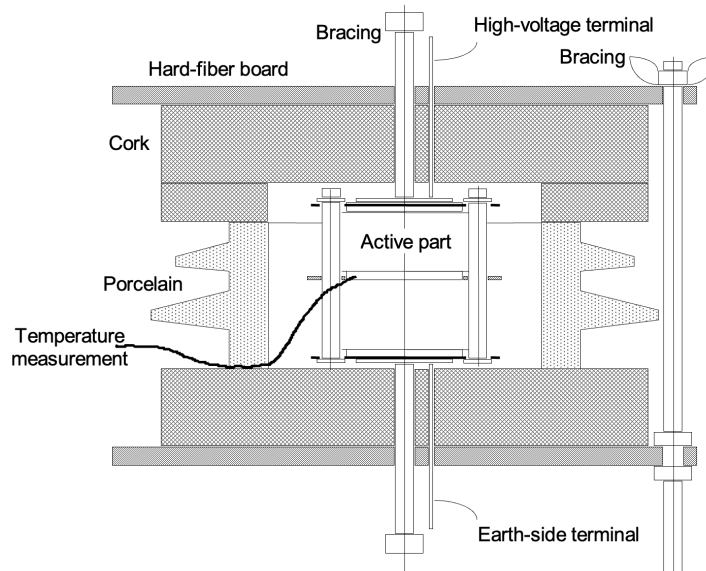

with the example shown here is that due to the small height, the heat dissipation in the radial direction cannot totally be prevented, no matter how good the thermal insulation of the ends is implemented. The thermally prorated section, therefore, typically dissipates heat better than a real arrester, which is not allowed. Since Ed. 3.0 of IEC 60099-4, the only requirement is that the thermally prorated section must thermally behave in the same way as the arrester represented, but may be completely different in design from that of the arrester. The thermal equivalence between the arrester and the prorated section has to be demonstrated by a type test (IEC 60099-4 Ed. 3.0, 8.6). Of course, such thermally prorated section no longer reflects the dielectric properties of the arrester. Therefore, a [dielectrically prorated section](#) must also be checked that has the same structure as the arrester, but does not have to be thermally equivalent at the same time.

**Thermal instability:** the (unstable) operating condition of an arrester, which has been heated beyond its →[thermal stability limit](#) (refer to [Figure 8](#)) by injecting impermissibly high energy, while being connected to power-frequency voltage. If it is not disconnected quickly enough, the arrester heats itself up because of the greatly increased leakage current, until it self-destructs (also known as “thermal runaway”).

**Thermal model of an arrester:** →[thermally equivalent prorated section](#)

**Thermal runaway:** →[thermal instability](#)

**Thermal stability limit:** highest temperature of the MO resistors, at which an arrester at applied power-frequency voltage and at the highest ambient temperature of +40 °C, as defined by the →[normal service conditions](#), can still cool down to its normal operating temperature. Also see [Figure 8](#) with the accompanying explanation. The values of the thermal stability limit, depending on the actual arrester design, are in the range of 190 °C to about 220 °C.

TLA: → [line arrester](#)

TLSA: → [line arrester](#)

TOV: → [temporary overvoltage](#)

Transmission line (surge) arrester: → [line arrester](#)

**Traveling waves:** Voltage and current impulses spread as traveling waves on the line when their rise time or their overall duration of appearance is shorter than the propagation time of an electromagnetic wave on a line (which under this condition is called an “electrically long line”). They always occur in fast-front overvoltages (principal cause: lightning overvoltages), but almost never in slow-front overvoltages (principal cause: switching overvoltages). The amplitudes of the voltage and current waves in this case are linked to each other by the → [surge impedance](#)  $Z$  of the line ( $U = Z \cdot I$ ). According to the rules of traveling wave processes, refraction and reflection occur where the surge impedance of the line changes. For example if a line with surge impedance  $Z_1$  meets another line with surge impedance  $Z_2$  or a terminating resistor with (real-valued) impedance  $Z_2$ , the voltage refraction factor is  $\beta_u = 2 \cdot Z_2 / (Z_2 + Z_1)$  and the voltage reflection factor is  $r_u = (Z_2 - Z_1) / (Z_2 + Z_1)$ . This especially can lead to voltage amplitude and voltage steepness increases (in extreme cases, up to double the amount) and is to be taken into account when determining the protection level of an arrester and its location (→ [protective zone of an arrester](#)).

**Type tests:** According to IEC 60099-4 Ed. 3.0, 8.1, MO arresters without gaps are to be subjected to the following type tests:

- insulation withstand tests on the housing
- → [residual voltage](#) tests
- test to verify long-term stability under continuous operating voltage
- → [repetitive charge transfer withstand](#)
- → [heat dissipation behaviour verification of test sample](#)
- → [operating duty test](#)
- → [power-frequency voltage versus time test](#)
- → [arrester disconnect/fault indicator \(when fitted\)](#)
- → [short-circuit tests](#)
- test of the bending moment
- environmental tests
- seal leak rate test
- → [RIV test](#)
- → [test to verify the dielectric withstand of the internal components of an arrester](#)
- test of internal grading components
- polluted housing test

$U_c$ : → [continuous operating voltage of an arrester](#)

$U$ - $I$ -characteristic: → [voltage-current-characteristic](#)

$U_m$ : → [highest voltage for equipment](#)

$U_n$ : → [nominal voltage of a system](#)

UHV system: → [system voltage levels](#)

**Unified specific creepage distance:** (USCD) → [creepage distance](#) of an insulator in relation to the value of the [highest voltage for equipment](#) of the insulator divided by the square root of three ( $U_m/\sqrt{3}$ ), and given in mm/kV. For example, an insulator with a creepage distance of 10 500 mm for use in a 420 kV system has a unified specific creepage distance of 43.3 mm/kV. IEC 60815, Ed. 1 of 1986 still referred to the → [specific creepage distance](#), which uses the phase-to-phase voltage as the reference value and

therefore differs from the unified specific creepage value by a factor of  $\sqrt{3}$ . The new series IEC60815-1, -2 and -3 introduced the unified specific creepage distance in 2008. The specific creepage distance is selected on the basis of the relevant [pollution level](#).

**Unit of an arrester:** a completely housed part of an arrester which may be connected in series and/or in parallel with other units to construct an arrester of higher [rated voltage](#) and/or current rating (IEC 60099-4 ed. 3.0, 3.79).

: [lightning impulse protection level](#) (LIPL)

$U_{ps}$ : [switching impulse protection level](#) (SIPL)

$U_r$ : [rated voltage of an arrester](#)

$U_{ref}$ : [reference voltage](#)

$U_{res}$ : the [switching impulse residual voltage](#) at the lower of the two given amplitudes for [switching current impulses](#) in Table 4 of IEC 60099-4 Ed. 2.2 (these were  $\hat{i} = 125$  A for 10 kA arresters of LD classes 1 and 2,  $\hat{i} = 250$  A for 10 kA arresters of LD class 3, and  $\hat{i} = 500$  A for 20 kA arresters of LD classes 4 and 5). It was used to determine the energy conversion during a [line discharge test](#), see [Figure 28](#).  $U_{res}$  is not used anymore according to IEC 60099-4 Ed. 3.0.

$U_{rw}$ : [required withstand voltage](#)

$U_s$ : [highest voltage of a system](#)

USCD: [unified specific creepage distance](#)

**U-t-characteristic:** [power-frequency voltage versus time characteristic](#)

$U_w$ : [standard withstand voltage](#)

**Vacuum-impregnated FRP tube:** implementation of an [FRP](#) tube which is manufactured by impregnating the previously wound dry fiber-glass construction in resin, under vacuum conditions. By using this manufacturing process, total absence of voids can be achieved (thus eliminating the risk of internal partial discharges and related deterioration effects, even under highest electric fields stress conditions), as well as high bending strength, when the glass fibers are mostly orientated in axial direction, which is not possible with the [wet-process](#). This type of manufacturing is, however, more expensive than the wet-process.

**Very-fast-front overvoltage:** transient overvoltage, normally unidirectional, with time to peak not greater than  $0.1 \mu\text{s}$ , a total duration below 3 ms, and with superimposed oscillations at a frequency between 30 kHz and 100 MHz (IEC 60071-1 Ed. 9.0, 3.17.2.3).

**V-I-characteristic:** [voltage-current-characteristic](#)

**Virtual front time of a current impulse ( $T_f$ ):** the time in microseconds equal to 1.25 the time in microseconds for the current to increase from 10% to 90% of its peak value (IEC 60099-4, 3.81).

**Virtual time to half-value on the tail of an impulse ( $T_2$ ):** the time interval between the virtual origin of the impulse and the instant in which the voltage or the current has decreased to half of its peak value; expressed in microseconds (IEC 60099-4 Ed. 3.0, 3.84).

**Voltage-current-characteristic:** (also: *U-I*-characteristic or *V-I*-characteristic) representation of the dependency of arrester voltage on current. Usually the voltage peak values are on the ordinate, frequently with per unit values related to the [lightning impulse protection level](#). The current peak values (resistive component only) are on the abscissa, represented logarithmically and within a range of

several decades of magnitude (e.g. from 10  $\mu\text{A}$  to 100 kA). [Figure 2](#) shows an example of a voltage-current characteristic. However, this is a simplified representation. In fact, there are slightly different characteristic curves, depending on which current form is used to measure. The measurement is carried out with 50/60 Hz power-frequency voltage, with [switching current impulses](#), with [lightning current impulses](#) and with [steep current impulses](#). The power-frequency voltage measurement can usually only be carried out up to current values of approx. 1 A, so that the characteristic curve is often interpolated from there to the switching impulse voltage curve. The reason for this is the strong self-heating of the MO resistors at high alternating currents as well as limitations due to the available power-frequency voltage sources, which increasingly show deviations from ideal sinusoidal voltages with the highly non-linear resistive current loads. The unavoidable inductive component due to the arrester's self-inductance must be included in the characteristic curve for steep current impulses, which is why its actual course depends on the arrester length. The following figure shows an example of a complete characteristic curve, as shown only in simplified form in [Figure 2](#).

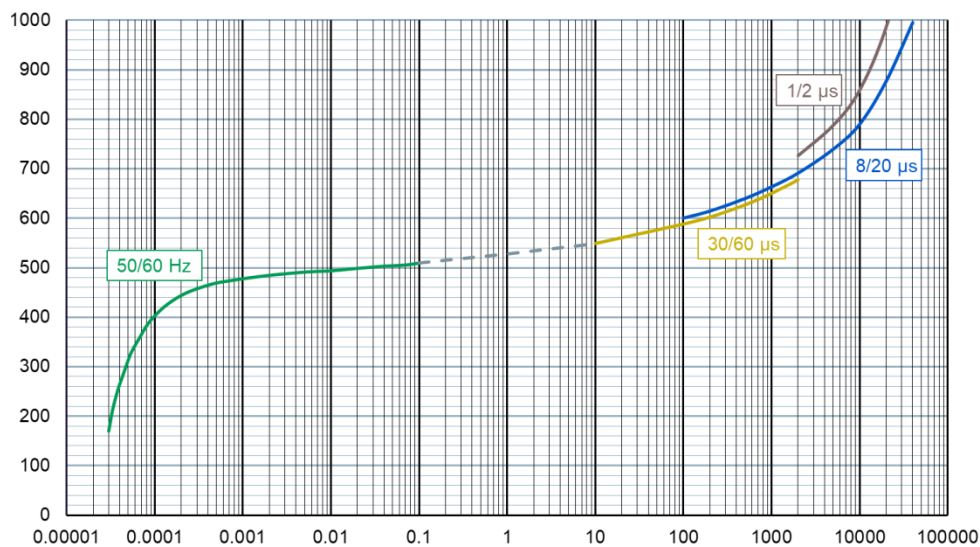

**V-t-characteristic:** → [power-frequency voltage versus time characteristic](#)

**Vulcanization:** cross-linking of the individual molecule chains of a polymer material to a three-dimensional network. The cross-linked material is often designated with an additional "XL". Example: the thermoplastic polyethylene (PE) becomes thermo-elastic cross-linked polyethylene (XLPE).

$W_{th}$ : → [thermal energy rating](#)

**Wet-processed FRP tube:** → [FRP](#) tube, which is manufactured by winding up resin impregnated fiber-glass rovings on a core. This production process requires that the glass fibers can only be set up diagonally (thus, for example, not exactly in the direction of the core axis, as is possible with → [vacuum-impregnated FRP tubes](#)). As a result the achievable bending strength usually remains below that of a similarly dimensioned vacuum-impregnated tube when the direction of the glass fibers is mostly in axial direction. On the other hand, axially oriented glass fibers support the mechanical strength against internal overpressure, which is helpful to achieve a [high short-circuit withstand capability](#). In the wet-process, voids cannot totally be avoided. These can cause dielectric and ageing problems under extremely high electric field stress in service (risk of internal partial discharges; however, the critical electric field stress is never achieved when the FRP tubes are used for the composite housings of outdoor arresters). Wet-processed tubes are easier to manufacture than vacuum-impregnated tubes.

**Withstand voltage:** the value of the test voltage to be applied under specified conditions in a withstand test, during which a specified number of disruptive discharges is tolerated (IEC 60071-1 Ed. 9.0, 3.24; see there also for additional details).

**ZnO resistor:** → [MO resistor](#)

## Published by

Siemens Energy Global GmbH & Co. KG  
Grid Technologies  
Siemenspromenade 9  
91058 Erlangen  
Germany

For the U.S. published by  
Siemens Energy, Inc  
Grid Technologies  
8841 Wadford Drive  
Raleigh, NC 27616  
USA

For more information, please visit our website:

[siemens-energy.com/arresters](https://www.siemens-energy.com/arresters)

or contact us: [arrester.energy@siemens-energy.com](mailto:arrester.energy@siemens-energy.com)

© Siemens Energy, 2024

Siemens Energy is a trademark licensed by Siemens AG.

Subject to changes and errors. The information given in this document only contains general descriptions and/or performance features which may not always specifically reflect those described, or which may undergo modification in the course of further development of the products. The requested performance features are binding only when they are expressly agreed upon in the concluded contract. All product designations may be trademarks or product names of Siemens Energy Global GmbH & Co. KG or other companies whose use by third parties for their own purposes could violate the rights of the owners.