

# Medium-voltage surge arresters



# Surge arresters

## Definition

Surge arresters are used to protect electrical equipment, like transformers, circuit-breakers, and bushings, against the effects of overvoltages caused by incoming surges. Such overvoltages can be caused by a direct or nearby lightning strike, an electromagnetic pulse, electrostatic discharge, or switching operations in the power supply system as well as in devices. Some overvoltages are very high in energy. The current from the surge is diverted through the arrester, in most cases to earth. Effective overvoltage protection requires different surge arrester types to be used according to the particular application.



## The Energy-Shop

You have the possibility to purchase our surge arresters online, in our Energy Shop. There you can select your individual surge arrester and order directly.

Please click on the link or use the QR-code and register yourself.

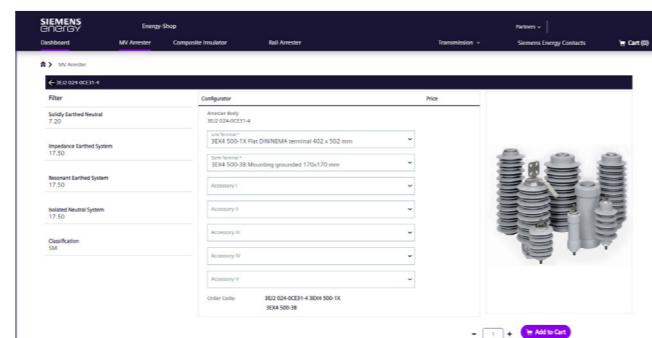
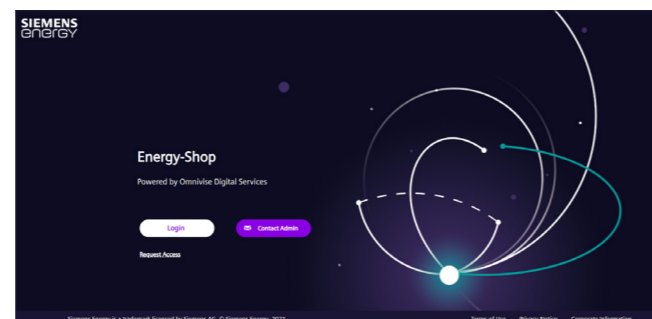

Please click on the link or use the QR-code and register yourself. <https://shop.siemens-energy.com/transmission/en>

<b>02</b>	Definition of surge arresters	<b>17</b>	3EK Distribution class surge arresters
<b>04</b>	Portfolio overview	<b>49</b>	3EH4 Medium-voltage plug-in arresters
<b>06</b>	MOVs: the core of Siemens Energy surge arresters	<b>63</b>	3EJ High energy discharge surge arresters
<b>07</b>	Standards and testing	<b>89</b>	3EP-G Porcelain surge arresters
<b>09</b>	How to select a suitable surge arrester	<b>93</b>	Glossary
<b>14</b>	Typical voltages and selection data		

# Siemens Energy surge arresters for any requirement

Experience is most essential when it comes to reliability in medium- and high-voltage applications. Siemens Energy has been designing and manufacturing medium- and high-voltage surge arresters for standard and special applications since 1925. Continuous research and development, the wealth of Siemens Energy know-how, and comprehensive worldwide experience give Siemens Energy surge arresters a leading edge in overvoltage protection. Their uncompromising quality ensures a long service life and reliability in any application.

Siemens Energy surge arresters are an indispensable aid to insulation coordination in electrical power supply systems. Valuable equipment such as transformers, circuit breakers, generators, motors, capacitors, traction vehicles and bushings, as well as complete switchgear, is optimally protected against lightning and switching overvoltages.

Siemens Energy surge arresters have been designed to meet the requirements of a wide range of common installation conditions, from arctic cold to the heat of the desert and the dampness of tropical climates. They are available for any application from 3 kV up to 1,200 kV including special applications such as high-voltage direct current (HVDC) and FACTS systems as well as all kinds of compensation systems for electric power networks.

## Siemens Energy offers a complete portfolio of surge arresters for all application areas and voltage levels

- High-voltage surge arresters for the protection of substation equipment for applications up to 1,200 kV
- Medium-voltage surge arresters for the protection of medium-voltage systems and components up to 72.5 kV
- Gas-insulated, metal-enclosed surge arresters for standard AC and DC applications from 72.5 kV to 800 kV
- Line surge arresters to improve network protection and to increase the reliability of the entire transmission system
- Surge arresters for railway applications for the protection of every part of a railway system

# Medium-voltage surge arresters



Siemens Energy provides a wide range of surge arrester product families for the protection of medium-voltage systems and components up to 72.5 kV. The selection of the surge arrester depends on the application to be protected:

## Distribution systems

Siemens Energy's **3EK** distribution class surge arrester product family is ideally suited for the reliable protection of transformers, circuit breakers, medium-voltage switchgear / panels and distribution lines.

## Surge arresters with high energy discharge capability

Next to the typical distribution class surge arresters, Siemens Energy offers the **3EJ Cage Design™** surge arrester product family with higher energy discharge capabilities in combination with a low protection level. The **3EJ surge arresters** protect rotating devices, like generators

and motors, arc furnaces, arc furnace transformers, industrial transformers, airfield-lighting systems, cable sheath, capacitors and capacitor banks and converters for drives.

## Special applications

For the overvoltage protection of generators and motors, which require a very high short-circuit current capability, Siemens Energy offers the **3EP-G** porcelain housed surge arresters with short-circuit current capability up to 300 kA.

The medium-voltage surge arresters are described in more detail in the next sections of this catalogue.

# MOVs:

the core of Siemens Energy surge arresters



The main task of an arrester is to protect equipment from the effects of overvoltages. During normal operation, an arrester should have no negative effect on the power system. Moreover, the arrester must be able to withstand typical surges without incurring any damage. Nonlinear resistors fulfill these requirements thanks to the following properties:

- Low resistance during surges, so that overvoltages are limited
- High resistance during normal operation to avoid negative effects on the power system
- Sufficient energy discharge capability for stable operation

With this kind of nonlinear resistor, there is only a small flow of current when continuous operating voltage is being applied. When there are surges, however, excess energy

can quickly be removed from the power system by a high discharge current.

Nonlinear resistors made of metal oxide (MO) have proven especially suitable for this use. The nonlinearity of MO resistors is considerably high, which is why MO arresters do not need series gaps. Siemens Energy has many years of experience with gapless MO arresters in low-voltage systems, distribution systems, and transmission systems. Siemens Energy metal oxide resistors (MOVs) provide a high energy discharge capability providing a very low protection level. This means they absorb a high amount of energy while avoiding thermal runaways. The MOVs are characterized by their high long-duration current impulse withstand capability – an indirect measure of their single impulse energy discharge capability. Siemens Energy surge arresters are less prone to self-heating and consequent self-destruction, and they maintain their characteristics throughout their lifetime.

# Standards and testing

Reliability you can count on

## Tests

Siemens Energy surge arresters have been designed and tested in compliance with the latest IEC 60099-4, IEEE C62.11, and GB 11032 standards. All type tests are performed by independent, PEHLA- certified laboratories; reports are available on request. Please contact your Siemens Energy representative for details.

Moreover, every single surge arrester that leaves the Siemens Energy factory undergoes a routine test and is delivered with a routine test certificate.

## Quality Assurance

Siemens Energy meets all requirements of ISO 9001:2008, ISO 14002:2004, and BS OHSAS 18001:2007. All Siemens Energy suppliers need to be certified according to ISO standards or will be audited by Siemens Energy.

To maintain sustainable quality improvement, Siemens Energy introduced corporate quality guidelines that contribute to each step of the quality process.

## Standardization

The aim of the IEC's Technical Committee 37 (TC 37) as well as the IEEE's Surge Protective Device Committee (SPDC) is the standardization of surge arrester testing and application. The TC 37 develops the standards IEC 60099-4, IEC 60099-8 (EGLA), IEC 60099-9 (HVDC), and the application guide IEC 60099-5, while the SPDC develops the standard IEEE C62.11 and the application guide IEEE C62.22. Both committees include representatives of manufacturers, utilities, test field labs, and universities.

Siemens Energy R&D experts are members of both bodies, thus playing an important role in the definition of the standards. They also share their expert knowledge in electrical power systems in CIGRE, the international council on large electric systems, which participates in the development of international standards.

Innovations in terms of arrester design and manufacturing processes are protected by a wide portfolio of Intellectual Property (IP) rights.



The test field is certified by the »Deutsche Akkreditierungsstelle« (Germany's national accreditation body) according to DIN EN ISO/IEC 17025



Test generator supplying both impulse voltages (1.2/50 μs and 250/250 μs) and impulse currents (8/20 μs and 30/60 μs)



UHV arrester prepared for testing in the HV test laboratory

# How to select a suitable surge arrester

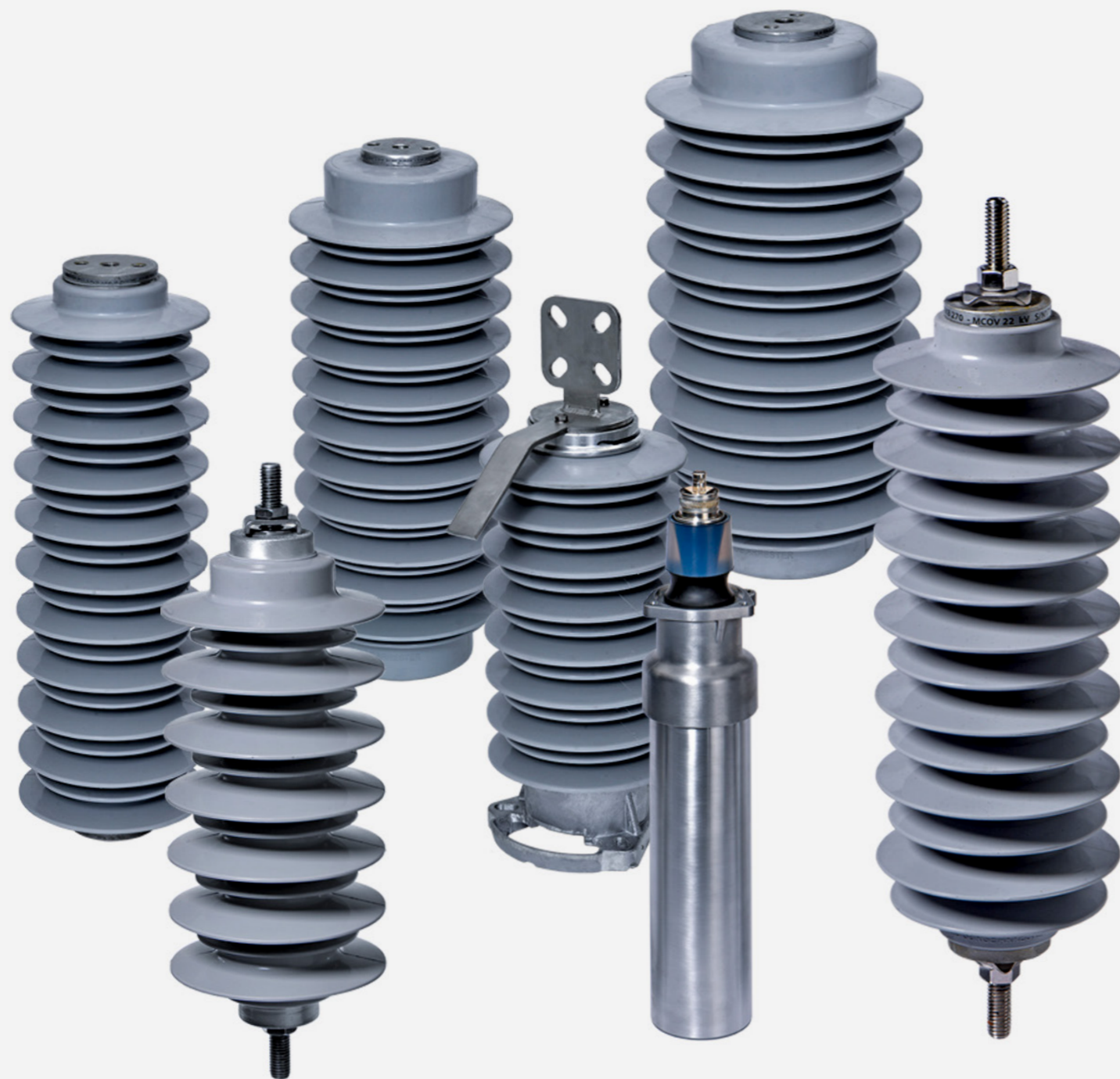

This section describes the general approach to selecting typical arresters for overvoltage protection in medium-voltage systems. The requirements for a surge arrester emerge from two basic requirements: It should provide adequate protection with a sufficient safety margin, which means that overvoltages at the device to be protected must always remain below its withstand voltage. Furthermore, the surge arrester should be dimensioned for stable continuous operation, which means that the arrester must remain electrically and thermally stable under all conditions while handling all long-term, temporary, and transient stress resulting from network operation. These two requirements cannot be fulfilled independently. A reduction of the protective level automatically means a higher degree of specific electrical stress during continuous operation, and conversely, the continuous operating voltage of an arrester cannot be increased arbitrarily without raising its protective level as well. Both operating points are for a given type of MOV strictly associated with each other through the voltage-current (U-I) characteristic curve.

## Step 1:

### Selection of the continuous operating voltage and the rated voltage

The first step is to define the minimally required continuous operating voltage  $U_{c,min}$ . This must be as high as the continuous phase-to-earth voltage of the system. Here, »continuously« applied voltage means every voltage that occurs within an uninterrupted period of more than 30 minutes.

**The type of neutral earthing of the system is decisive in determining the continuous operating voltage.**

In isolated or resonant earthed neutral systems, the voltage of a healthy phase against ground takes on the value of the phase-to-phase voltage in the case of a one-phase earth fault (earth fault factor  $k = 1.73$ ). Since resonant earthed neutral systems are operated quite commonly for time periods of more than 30 minutes in this condition, the continuous operating voltage of the arrester must, in this case, have the value of the highest voltage of the system,  $U_s$ .

Solidly earthed neutral system:

$$U_{c,min} \geq U_s / \sqrt{3}$$

Isolated or resonant earthed neutral system:

$$U_{c,min} \geq U_s$$

Example for a 24 kV system, solid earthing:

$$U_s = 24 \text{ kV}$$

$$U_{c,min} = 13.9 \text{ kV}$$

$$U_{r,min} = 17.3 \text{ kV}$$

$$\text{Typical } U_r = 18 \text{ kV}$$

Example for a 24 kV system, isolated neutral:

$$U_s = 24 \text{ kV}$$

$$U_{c,min} = 24 \text{ kV}$$

$$U_{r,min} = 30 \text{ kV}$$

$$\text{Typical } U_r = 30 \text{ kV}$$

The definition of the minimally required continuous operating voltage, a factor which usually has a value of 1.25, helps achieve a rated voltage  $U_r = 1.25 \cdot U_{c,min}$ . This is the lowest necessary rated voltage of the arrester.

Table »Typical rated voltages  $U_r$  for highest voltages of the system  $U_s$ « on page 12 and 13 lists typically applied rated voltages.

**Step 2:**  
**Selection of the nominal discharge current  $I_n$**

The nominal discharge current  $I_n$  serves to classify a surge arrester. From a technical point of view, it is calculated from a typical maximum lightning current amplitude that can be expected in the substation, for which the insulation coordination is performed via the arrester's lightning protection level. This amplitude is calculated from the flashover voltage  $U_{fo}$  of the line insulators, the lightning protection level  $U_{pl}$  of the arresters, and the surge impedance  $Z$  of the line for  $I_{max}$ :

$$I_{max} = (2 \cdot U_{fo} - U_{pl}) / Z$$

Example for a 24 kV system:

$$U_{fo} = 250 \text{ kV}$$

$$U_{pl} = 80 \text{ kV}$$

$$Z = 450 \text{ Ohm}$$

$$I_{max} = 0.9 \text{ kA}$$

A 10 kA arrester, for instance, can readily withstand lightning current impulses of higher amplitudes without severe damage.

**Step 3:**  
**Selection of protective levels**

The protective characteristics of an arrester are most frequently assessed by means of its lightning impulse protective level: It is assessed according to its residual voltage while the nominal discharge current is flowing. This usually means that a protective level equaling the standard lightning impulse withstand voltage of the device to be protected and divided by a factor of 1.4 is adequate for protection against lightning overvoltages.

$$U_{pl, 10 \text{ kA}, 8/20\mu\text{s}} < \text{BIL} / 1.4$$

The selection of the electrical characteristics of the arrester is finished when the requirements regarding the protective levels of all mentioned current impulse stresses are fulfilled.

Example U-I-curve 30 kV arrester

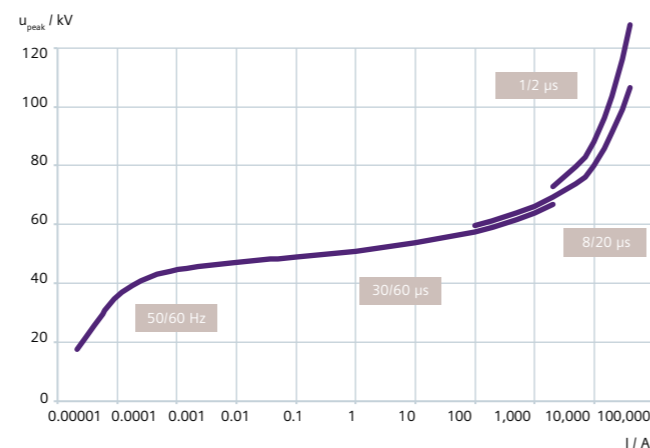

**Step 4:**  
**Selection of the energy class**

The application guide IEC 60099-5 to the standard IEC 60099-4 describes how the charge transfer and energy handling capability of a surge arrester can be determined. Surge arresters dissipate switching surges by absorbing energy. The charge transfer and amount of energy is related to the switching surge magnitude and wave shape, the system impedance, the arrester protective characteristics, and the number of switching operations.

The selected arrester should have charge and energy rating capability greater than the accumulated charge transferred and energy associated with the expected highest surges on the system.

The application guide IEC 60099-5 offers equations to estimate charge transfer and the energy handling capability requirements of surge arresters.

$$Q_s = (U_{rp} - U_{ps}) \times 2 \times L / c \times Z_s$$

$$W_s = U_{ps} \times Q_s$$

**Where:**

$U_{rp}$  is the representative maximum switching voltage (in kV)

$U_{ps}$  is the arrester residual voltage during the line discharge (in kV)

$L$  is the line length with surge travel at light speed  $c$   
 $c$  is the speed of light (300,000 km/s)

$Q_s$  is the cumulative charges transferred during single line switching (in Coulombs)

$W_s$  is the cumulative energy absorbed by the arrester during single line switching (in kJ/kV)

The application guide IEEE C62.22 offers equations to estimate the energy handling capability requirements of surge arresters. The energy discharged by an arrester  $J$  in kJ may be estimated by the equation:

$$J = 2D_L E_A I_A / v$$

**Where:**

$D_L$  is the line length (in kilometers)

$E_A$  is the arrester switching impulse discharge voltage (in kV) for IA

$I_A$  is the switching impulse current (in kA)

$v$  is the speed of light, 300,000 km/s

The equations assume that the entire line is charged to a prospective switching surge voltage (which exists at the arrester location) and is discharged through the arrester at its protective level during twice the travel time of the line. The single discharge voltage and current are related by the equation:

$$I_A = (E_S - E_A) / Z$$

**Where:**

$E_S$  is the prospective switching surge voltage (in kV)

$Z$  is the single-phase surge impedance of line (in ohms)

The table below shows the definition of the energy class according to standard IEEE C62.11. This energy is not a fixed value, but instead depends on the arrester's protective level. The higher the discharge voltage, the less energy the arrester absorbs during the line discharge, since the line will discharge less intensely when the discharge voltage is higher.

Energy class	A	B	C	D	E	F	G	H	J	K	L	M	N
Energy rating (Two shot) kJ/kV <sub>MCOV</sub>	3.0	4.5	6.0	7.5	9.0	11	13	15	18	21	24	27	30

**Step 5:**

**Protective zone**

The protection of the equipment by an arrester can be guaranteed only for short distances between arrester and equipment, due to travelling wave effects on the line. Rapidly increasing overvoltages spread in the form of traveling waves on the line. Refraction and reflection occur in places where the surge impedance of the line changes.

The maximum distance between surge arrester and equipment to be protected is described with following formula:

$$x_s = (BIL / 1.15 - U_{pl}) v_{tw} / 2s$$

Example for a 24 kV system, solid earthing:

$$U_s = 24 \text{ kV}$$

$$BIL = 125 \text{ kV}$$

$$U_{pl} = 47.7 \text{ kV}$$

$$x_s = 9.1 \text{ m}$$

Example for a 24 kV system, isolated neutral:

$$U_s = 24 \text{ kV}$$

$$BIL = 125 \text{ kV}$$

$$U_{pl} = 79.5 \text{ kV}$$

$$x_s = 4.4 \text{ m}$$

**Where:**

- $x_s$  protective zone (in m)
- BIL basic insulation level of equipment (in kV)
- $U_{pl}$  protection level of the arrester (in kV)
- $s$  front steepness of incoming surge (in kV/ $\mu$ s) (in the range of 1000 kV/ $\mu$ s)
- $v_{tw}$  propagation speed of travelling wave: 300 m/ $\mu$ s (overhead line) (equals „c“)

**Clearances**

$U_r$	Clearance	
	phase to phase	phase to ground
kV	mm	mm
3	140	90
6	140	90
9	170	120
12	170	120
15	210	130
18	220	145
21	240	165
22	250	175
24	270	185
25	280	190
27	290	205
30	320	225
31.5	330	235
33	340	245
36	370	265
39	390	285
42	420	305
45	440	325
48	470	345
51	490	365
54	520	385
60	570	425

### Typical rated voltages $U_r$ for highest voltages of the system $U_s$ according to IEC 60099-4.

Highest voltage of system $U_s$ kV	Solidly earthed neutral system $U_r$ kV	Isolated neutral system; Delta winding $U_r$ kV	Impedance earthed neutral system $U_r$ kV	Resonant earthed neutral system $U_r$ kV
3.6	3	6	3	6
7.2	6	9	9	9
12	9	15	12	15
17.5	15	24	15	24
24	18	30	21	30
36	27	45	33	45
52	39	66 <sup>1)</sup>	45	66 <sup>1)</sup>
72.5	54	96 <sup>1)</sup>	66 <sup>1)</sup>	96 <sup>1)</sup>

1) High-voltage surge arrester

### Typical duty cycle voltages $U_r$ for highest voltages of the system $U_s$ according to IEEE C62.11.

System L-L voltage $U_s$ kV	Four-wire multi-grounded neutral wye $U_r$ kV	Three-wire low impedance neutral circuit $U_r$ kV	Three-wire high impedance neutral circuit $U_r$ kV
4.16	3	6	6
6.9			9
8.3	6	9	
12	9	12	
12.47	9 or 10	15	
13.8	10 or 12	15	18
22.86	15	21	
23			30
34.5	27	36	

### Product range and selection data

Siemens Energy offers multiple models of each surge arrester product family. The following selection tables show the main technical data according to IEC60099-4 resp. IEEE C62.11 of the different product lines. Detailed technical data is listed in the sections for each dedicated product line.

For additional specifications, please contact your local Siemens Energy representative.

### Main technical data according to IEC 60099-4

Designation	Maximum rated voltage $U_r$ / kV			Distribution applications							High energy applications & Protection of rotating devices					Plug-in applications		
	Nominal discharge current $I_n$ kA	Thermal charge transfer rating $Q_m$ C	Charge transfer rating $Q_n$ C	3EK7	3EK8	3EJ2	3EJ3	3EJ4	3EJ0	3EJ9	3EP-G	3EH4	3EK7	3EK8	3EJ2	3EJ3	3EJ4	
DH	10	1.1	0.4		x													x
DM	5	1.1	0.4	x														
SL	10	5.0	1.2	x														
SM	10	4.0	2.0															x
SH	20	4.0	6.0			x												x
SH	20	10	2.8				x											
SH	20	14	3.6															
SH	20	18	6.0															
Rated short circuit current $I_s$ / kA				20	21	50	65	50	20	50	300	16						
High current impulse / kA				100	100	100	100	100	100	100	100	100						
Indoor version available				X				x	x	x								

### Main technical data according to IEEE C62.11

Energy class	Maximum rated voltage $U_r$ / kV			Distribution applications		High energy applications & Protection of rotating devices		
	Lightning impulse classifying current	Switching surge energy rating	Single impulse withstand rating	3EK7	3EK8	3EJ2	3EJ3	3EJ4
A	10	3.0	0.4		x			
B	10	4.5	0.5	x				
E	10	9.0	2.0			x		
G	15	13	2.8				x	
J	20	18	3.6					x
K	20	21	6.0					x
Rated short circuit current $I_s$ / kA				20	21	50	65	50
High current impulse / kA				100	100	100	100	100
Indoor version available				x				x

# 3EK Distribution class surge arresters with silicone rubber housing

Siemens Energy cage design and wrap design 3EK distribution class surge arresters offer superior protection against overvoltages in medium-voltage systems.

A disconnecter is a device at the earth terminal of the arrester, which separates the arrester from the system after an overloading. Without a disconnecter – at least in a solidly earthed neutral system – a subsequent operation of the appropriate line section would no longer be possible. The disconnecter is of great importance for a trouble-free operation of a distribution network.

Disconnectors are only used in distribution systems. One of the most common working principles of disconnectors is the ignition of a small explosive device (e.g., the cartridge of a gas pistol) caused by the thermal effect of the power-frequency earth fault current, which flows after an arrester failure. The explosive device tears the surrounding polymeric housing and causes the flexible earthing lead to disconnect from the arrester.

The metal oxide resistors (MOV) are enclosed by a cage made of fiber-reinforced plastic (FRP) rods, providing a rigid, reinforced structure ensuring high mechanical strength.

Reliability is guaranteed by the direct molding of the silicone rubber onto the MOVs and the FRP rods. This ensures the total embedding of all components free of inclusions and gaps, thus providing an excellent sealing system against moisture ingress, which avoids partial discharges.

In the extremely rare event of the MOVs being overloaded, arcing cannot result in a buildup of critical internal pres-

sure, since the MOVs are not enclosed in a sealed mechanical shell. The arc can escape directly through the soft silicone housing, leaving the mechanical support structure of the enclosure unharmed. The ejection of internal parts that could damage other equipment nearby is prevented almost completely. Siemens Energy' innovative cage design ensures outstanding performance in safety issues.

Silicone rubber is highly hydrophobic and maintains its ability to repel water and any deposits of pollution throughout its entire service life. This results in high tracking and erosion resistance. The silicone rubber housing is self-extinguishing and flame-retardant. These advantages provide maintenance-free and reliable service life for 3EK surge arresters.

Siemens Energy offers two product lines for the application in distribution networks:

- **3EK7** – for rated voltages up to 60 kV, very high mechanical performance.
- **3EK8** – for rated voltages up to 36 kV

The proven 3EK7 is also available in a version for indoor application, which is a cage design surge arrester offering the same benefits as the version for outdoor application.

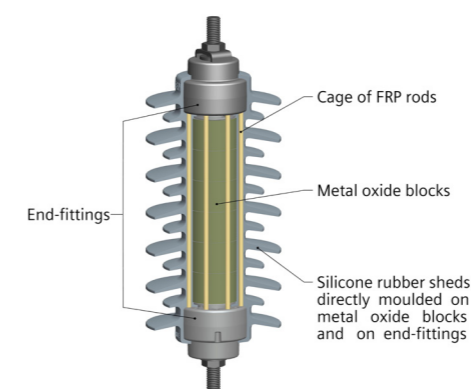

Siemens Energy 3EK cage design surge arresters are ideally suited for the reliable protection of:

- Transformers
- Circuit breakers
- Medium-voltage switchgear / panels
- Distribution lines

### 3EK7 specifications according to IEC 60099-4 standard

#### Electrical Characteristics

Rated voltage	Continuous operating voltage	Arrester type	Designation	Nominal discharge current	Charge transfer rating	Thermal charge transfer rating	Maximum values of the residual voltages at discharge currents of the following impulses						
							30/60µs 125 A kV	30/60µs 500 A kV	8/20µs 1 kA kV	8/20µs 3 kA kV	8/20µs 5 kA kV	8/20µs 10 kA kV	8/20µs 20 kA kV
3.0	2.4	3EK7 030 - 4 C B 4	DH	10	0.5	1.1	5.8	6.1	6.5	7.1	7.4	8.0	9.1
6.0	4.8	3EK7 060 - 4 C B 4	DH	10	0.5	1.1	11.6	12.2	13.0	14.2	14.8	15.9	18.3
9.0	7.2	3EK7 090 - 4 C B 4	DH	10	0.5	1.1	17.4	18.4	19.6	21.2	22.2	23.9	27.4
12	9.6	3EK7 120 - 4 C C 4	DH	10	0.5	1.1	23.2	24.5	26.1	28.3	29.6	31.8	36.6
15	12.0	3EK7 150 - 4 C C 4	DH	10	0.5	1.1	29.0	30.6	32.6	35.4	37.0	39.8	45.7
18	14.4	3EK7 180 - 4 C D 4	DH	10	0.5	1.1	34.8	36.7	39.1	42.5	44.4	47.7	54.9
21	16.8	3EK7 210 - 4 C D 4	DH	10	0.5	1.1	40.6	42.9	45.6	49.5	51.8	55.7	64.0
24	19.2	3EK7 240 - 4 C E 4	DH	10	0.5	1.1	46.4	49.0	52.2	56.6	59.1	63.6	73.1
27	21.6	3EK7 270 - 4 C E 4	DH	10	0.5	1.1	52.2	55.1	58.7	63.7	66.5	71.6	82.3
30	24.0	3EK7 300 - 4 C F 4	DH	10	0.5	1.1	58.0	61.2	65.2	70.8	73.9	79.5	91.4
33	26.4	3EK7 330 - 4 C H 4	DH	10	0.5	1.1	63.8	67.3	71.7	77.8	81.3	87.5	101
36	28.8	3EK7 360 - 4 C H 4	DH	10	0.5	1.1	69.6	73.5	78.2	84.9	88.7	95.4	110
39	31.2	3EK7 390 - 4 C H 4	DH	10	0.5	1.1	75.4	79.6	84.7	92.0	96.1	103	119
42	33.6	3EK7 420 - 4 C H 4	DH	10	0.5	1.1	81.2	85.7	91.3	99.1	104	111	128
45	36.0	3EK7 450 - 4 C H 4	DH	10	0.5	1.1	87.1	91.8	97.8	106	111	119	137
48	38.4	3EK7 480 - 4 C H 4	DH	10	0.5	1.1	92.9	97.9	104	113	118	127	146
51	40.8	3EK7 510 - 4 C J 4	DH	10	0.5	1.1	98.7	104	111	120	126	135	155
54	43.2	3EK7 540 - 4 C J 4	DH	10	0.5	1.1	104	110	117	127	133	143	165
60	48.0	3EK7 600 - 4 C J 4	DH	10	0.5	1.1	116	122	130	142	148	159	183

#### Mechanical Characteristics

Height [H]	Creepage distance	Rated short-circuit current	Lightning impulse withstand voltage	Power frequency withstand voltage, wet	Specified short-term load SSL		Specified long-term load SLL		Approximate weight of arrester without accessories	Flashover distance	Insulating bracket
					arrester only	with ins. bracket	arrester only	with ins. bracket			
170	372	20	104	49	2940	470	2050	320	1.5	180	short
170	372	20	104	49	2940	470	2050	320	1.6	180	short
170	372	20	104	49	2940	470	2050	320	1.6	180	short
200	485	20	122	57	2500	400	1750	280	1.9	210	short
200	485	20	122	57	2500	400	1750	280	2.0	210	short
240	605	20	144	67	2080	330	1450	230	2.3	248	long
240	605	20	144	67	2080	330	1450	230	2.4	248	long
270	775	20	166	77	1850	290	1290	200	2.7	286	long
270	775	20	166	77	1850	290	1290	200	2.8	286	long
300	900	20	184	86	1660	260	1160	180	3.1	318	long
400	1230	20	242	113	1250	200	870	140	3.9	418	long
400	1230	20	242	113	1250	200	870	140	4.0	418	long
400	1230	20	242	113	1250	200	870	140	4.1	418	-
400	1230	20	242	113	1250	200	870	140	4.1	418	-
400	1230	20	242	113	1250	200	870	140	4.2	418	-
400	1230	20	242	113	1250	200	870	140	4.3	418	-
470	1420	20	281	131	1060	170	740	110	4.9	484	-
470	1420	20	281	131	1060	170	740	110	5.0	484	-
470	1420	20	281	131	1060	170	740	110	5.1	484	-

#### How to order

##### 3EK7 IEC

###### Example 3EK7 360-4CH4

- 3EK7 ... Medium-voltage surge arrester
- 360 ... Rated voltage = 36 kV
- 4 ... LD class 1 [5 → LD class 2]
- C ... IEC
- H ... Housing type (H=400 mm)
- 4 ... Alternating sheds

###### Example 3EK7 360-4CH4-Z M11 P12 M81

- Z ... is indicating accessories

##### Accessories:

- M11 ... Line clamp (M=Line terminal)
- P12 ... NEMA insulating bracket (M=Ground terminal)
- M81 ... Bird protection cap

#### Dimensions 3EK7 IEC

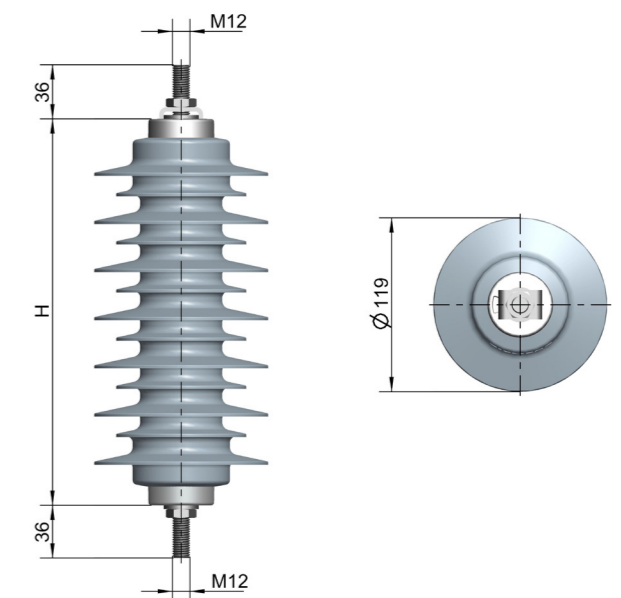

### 3EK7 SL according to IEC 60099-4 standard

Electrical Characteristics

Rated voltage $U_r$ kV	Continuous operating voltage $U_c$ kV	Arrester type	Designation	Nominal discharge current $I_n$ kA	Charge transfer rating $Q_{rs}$ C	Thermal charge transfer rating $Q_m$ kJ/kVr	Maximum values of the residual voltages at discharge currents of the following impulses						
							30/60 $\mu$ s 125 A kV	30/60 $\mu$ s 500 A kV	8/20 $\mu$ s 1 kA kV	8/20 $\mu$ s 3 kA kV	8/20 $\mu$ s 5 kA kV	8/20 $\mu$ s 10 kA kV	8/20 $\mu$ s 20 kA kV
3.0	2.4	3EK7 030 - 5 C B 4	SL	10	1.2	4.5	6.2	6.6	7.0	7.6	8.0	8.6	9.8
6.0	4.8	3EK7 060 - 5 C B 4	SL	10	1.2	4.5	12.5	13.2	14.0	15.2	15.9	17.1	19.7
9.0	7.2	3EK7 090 - 5 C C 4	SL	10	1.2	4.5	18.7	19.8	21.0	22.8	23.9	25.7	29.5
12	9.6	3EK7 120 - 5 C D 4	SL	10	1.2	4.5	25.0	26.3	28.0	30.4	31.8	34.2	39.3
15	12.0	3EK7 150 - 5 C D 4	SL	10	1.2	4.5	31.2	32.9	35.1	38.0	39.8	42.8	49.2
18	14.4	3EK7 180 - 5 C E 4	SL	10	1.2	4.5	37.4	39.5	42.1	45.7	47.7	51.3	59.0
21	16.8	3EK7 210 - 5 C F 4	SL	10	1.2	4.5	43.7	46.1	49.1	53.3	55.7	59.9	68.8
24	19.2	3EK7 240 - 5 C H 4	SL	10	1.2	4.5	49.9	52.7	56.1	60.9	63.6	68.4	78.7
27	21.6	3EK7 270 - 5 C H 4	SL	10	1.2	4.5	56.2	59.3	63.1	68.5	71.6	77.0	88.5
30	24.0	3EK7 300 - 5 C H 4	SL	10	1.2	4.5	62.4	65.8	70.1	76.1	79.5	85.5	98.3
33	26.4	3EK7 330 - 5 C J 4	SL	10	1.2	4.5	68.7	72.4	77.1	83.7	87.5	94.1	108
36	28.8	3EK7 360 - 5 C J 4	SL	10	1.2	4.5	74.9	79.0	84.1	91.3	95.4	103	118
39	31.2	3EK7 390 - 5 C J 4	SL	10	1.2	4.5	81.1	85.6	91.1	98.9	103	111	128
42	33.6	3EK7 420 - 5 C K 4	SL	10	1.2	4.5	87.4	92.2	98.2	107	111	120	138

Mechanical Characteristics

Height [H] mm	Creepage distance mm	Rated short-circuit current $I_s$ kA	Lightning impulse withstand voltage 1.2/50 $\mu$ s kV	Power frequency withstand voltage, wet 1 min. kV	Specified short-term load SSL		Specified long-term load SLL		Approximate weight of arrester without accessories kg	Flashover distance mm	Insulating bracket size
					arrester only N	with ins. bracket N	arrester only N	with ins. bracket N			
170	372	20	104	49	2940	470	2050	320	1.5	180	short
170	372	20	104	49	2940	470	2050	320	1.6	180	short
200	485	20	122	57	2500	400	1750	280	1.9	210	short
240	605	20	144	67	2080	330	1450	230	2.3	248	short
240	605	20	144	67	2080	330	1450	230	2.4	248	short
270	775	20	166	77	1850	290	1290	200	2.8	286	long
300	900	20	184	86	1660	260	1160	180	3.2	318	long
400	1230	20	242	113	1250	200	870	140	4.0	418	long
400	1230	20	242	113	1250	200	870	140	4.1	418	long
400	1230	20	242	113	1250	200	870	140	4.2	418	long
470	1420	20	281	131	1060	170	740	110	4.9	484	long
470	1420	20	281	131	1060	170	740	110	5.0	484	long
470	1420	20	281	131	1060	170	740	110	5.1	484	-
510	1595	20	302	140	980	150	680	100	5.4	520	-

#### How to order

##### 3EK7 IEC SL

Example 3EK7 360-4CH4	
3EK7	... Medium-voltage surge arrester
360	... Rated voltage = 36 kV
4	... LD class 1 [5 → LD class 2]
C	... IEC
H	... Housing type (H=400 mm)
4	... Alternating sheds
Example 3EK7 360-4CH4-Z M11 P12 M81	
-Z	... is indicating accessories
Accessories:	
M11	... Line clamp (M=Line terminal)
P12	... NEMA insulating bracket
M81	... Bird protection cap

#### Dimensions 3EK7 IEC SL

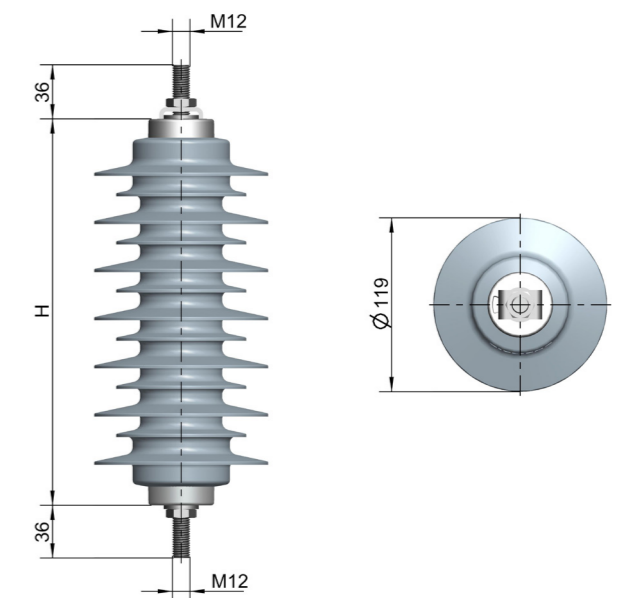

## 3EK7 specifications according to IEEE C62.11 standard

Electrical Characteristics

Duty cycle voltage	MCOV	Arrester order number	Energy class	Lightning impulse classifying current	Single impulse with-stand rating	Switching surge energy rating	Protective Level						
							Maximum discharge voltage						
							45/90µs 125 A kV cr	45/90µs 500 A kV cr	8/20µs 1.5 kA kV cr	8/20µs 3 kA kV cr	8/20µs 5 kA kV cr	8/20µs 10 kA kV cr	8/20µs 20 kA kV cr
kV	kV			I <sub>n</sub> kA	C	kJ/kV <sub>MCOV</sub>							
3.0	2.55	3EK7 030 - 3 A B 4	B	10	0.6	4.5	6.9	7.3	8.1	8.5	8.8	9.5	10.9
3.0	2.55	3EK7 030 - 4 A B 4	B	10	0.6	4.5	5.8	6.1	6.8	7.1	7.4	8.0	9.2
6.0	5.10	3EK7 060 - 3 A B 4	B	10	0.6	4.5	14.3	15.1	16.7	17.4	18.2	19.6	22.5
6.0	5.10	3EK7 060 - 4 A B 4	B	10	0.6	4.5	11.6	12.3	13.6	14.2	14.8	15.9	18.3
9.0	7.65	3EK7 090 - 3 A B 4	B	10	0.6	4.5	20.5	21.6	23.9	25.0	26.1	28.1	32.3
9.0	7.65	3EK7 090 - 4 A C 4	B	10	0.6	4.5	17.5	18.4	20.3	21.3	22.2	23.9	27.5
10	8.40	3EK7 100 - 3 A B 4	B	10	0.6	4.5	21.5	22.6	25.0	26.2	27.3	29.4	33.8
10	8.40	3EK7 100 - 4 A C 4	B	10	0.6	4.5	19.4	20.5	22.6	23.7	24.7	26.6	30.6
12	10.2	3EK7 120 - 3 A C 4	B	10	0.6	4.5	27.2	28.7	31.7	33.2	34.7	37.3	42.9
12	10.2	3EK7 120 - 4 A D 4	B	10	0.6	4.5	23.3	24.6	27.1	28.4	29.7	31.9	36.7
15	12.7	3EK7 150 - 3 A D 4	B	10	0.6	4.5	34.0	35.9	39.6	41.5	43.3	46.6	53.6
15	12.7	3EK7 150 - 4 A D 4	B	10	0.6	4.5	29.1	30.7	33.9	35.5	37.1	39.9	45.9
18	15.3	3EK7 180 - 3 A D 4	B	10	0.6	4.5	40.8	43.0	47.5	49.8	52.0	55.9	64.3
18	15.3	3EK7 180 - 4 A E 4	B	10	0.6	4.5	34.9	36.8	40.7	42.6	44.5	47.8	55.0
21	17.0	3EK7 210 - 3 A E 4	B	10	0.6	4.5	44.7	47.1	52.0	54.5	56.9	61.2	70.4
21	17.0	3EK7 210 - 4 A F 4	B	10	0.6	4.5	40.7	43.0	47.4	49.7	51.9	55.8	64.2
24	19.5	3EK7 240 - 3 A F 4	B	10	0.6	4.5	51.5	54.3	59.9	62.7	65.6	70.5	81.1
24	19.5	3EK7 240 - 4 A H 4	B	10	0.6	4.5	46.6	49.1	54.2	56.8	59.3	63.8	73.4
27	22.0	3EK7 270 - 3 A F 4	B	10	0.6	4.5	58.2	61.4	67.7	70.9	74.1	79.7	91.7
27	22.0	3EK7 270 - 4 A H 4	B	10	0.6	4.5	52.4	55.3	61.0	63.9	66.7	71.8	82.5
30	24.4	3EK7 300 - 3 A H 4	B	10	0.6	4.5	64.1	67.6	74.6	78.1	81.7	87.8	101
30	24.4	3EK7 300 - 4 A H 4	B	10	0.6	4.5	58.2	61.4	67.8	71.0	74.2	79.7	91.7
33	27.5	3EK7 330 - 3 A H 4	B	10	0.6	4.5	71.8	75.8	83.6	87.6	91.5	98.4	113
33	27.5	3EK7 330 - 4 A J 4	B	10	0.6	4.5	64.0	67.5	74.6	78.1	81.6	87.7	101
36	29.0	3EK7 360 - 3 A H 4	B	10	0.6	4.5	78.8	83.2	91.8	96.1	100	108	124
36	29.0	3EK7 360 - 4 A K 4	B	10	0.6	4.5	69.9	73.7	81.3	85.2	89.0	95.7	110

Mechanical Characteristics

Height [H]	Leakage distance	Rated short-circuit current	Recommended minimum clearances		Maximum design cantilever load MDCL		Specified short-term load SSL		Approximate weight of arrester without accessories	Insulating bracket
			To ground (ph-gnd)	Between phases (ph-ph)	arrester only	with ins. bracket	arrester only	with ins. bracket		
inch	inch	I <sub>s</sub> kA	inch	inch	lbf	lbf	lbf	lbf	lbs	size
6.7	14.6	20	4	6	370	74	529	106	2.8	short
6.7	14.6	20	4	6	370	74	529	106	2.8	short
6.7	14.6	20	4	6	370	74	529	106	3.2	short
6.7	14.6	20	4	6	370	74	529	106	3.2	short
6.7	14.6	20	5	7	370	74	529	106	3.2	short
7.9	19.1	20	5	7	315	63	450	90	3.5	short
6.7	14.6	20	5	7	370	74	529	106	3.5	short
7.9	19.1	20	5	7	315	63	450	90	3.5	short
7.9	19.1	20	5	7	315	63	450	90	4.1	short
9.4	23.8	20	5	7	262	52	375	75	4.1	short
9.4	23.8	20	5	7	262	52	375	75	5.1	short
9.4	23.8	20	5	7	262	52	375	75	4.4	short
9.4	23.8	20	6	9	262	52	375	75	5.4	long
10.6	30.5	20	6	9	233	47	333	67	5.1	long
10.6	30.5	20	6	9	233	47	333	67	6.1	long
11.8	35.4	20	6	9	210	42	300	60	5.4	long
11.8	35.4	20	7	11	210	42	300	60	6.7	long
15.7	48.4	20	7	11	157	31	225	45	6.1	long
11.8	35.4	20	8	11	210	42	300	60	7.0	long
15.7	48.4	20	8	11	157	31	225	45	6.7	long
15.7	48.4	20	9	13	157	31	225	45	8.2	long
15.7	48.4	20	9	13	157	31	225	45	7.0	long
15.7	48.4	20	10	13	157	31	225	45	8.5	long
18.5	55.9	20	10	13	134	27	191	38	8.2	long
15.7	48.4	20	10	15	157	31	225	45	8.9	long
20.1	62.8	20	10	15	123	25	176	35	8.5	long

### How to order

#### 3EK7 IEEE

##### Example 3EK7 360-3AH4

- 3EK7 ... Medium-voltage surge arrester
- 360 ... Rated voltage = 36 kV
- 3 ... IEEE classification heavy duty
- C ... IEEE
- H ... Housing type (H=400 mm)
- 4 ... Alternating sheds

##### Example 3EK7 360-3AH4-Z M11 P12 M81

- Z ... is indicating accessories

##### Accessories:

- M11 ... Line clamp (M=Line terminal)
- P12 ... NEMA insulating bracket (M=Ground terminal)
- M81 ... Bird protection cap

### Dimensions 3EK7 IEEE

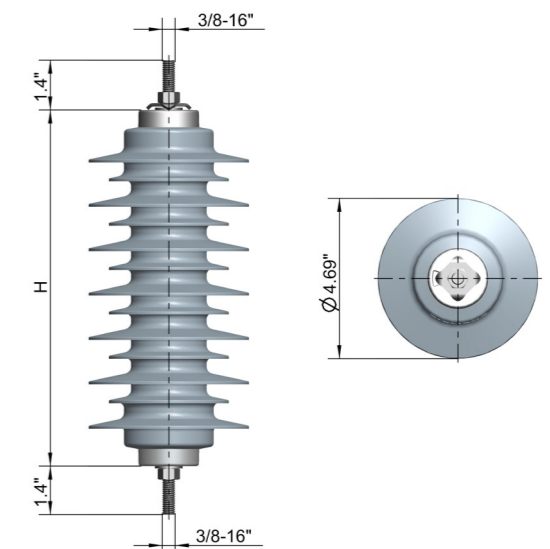

### 3EK7 indoor version specifications according to IEC 60099-4 standard

#### Electrical Characteristics

Rated voltage $U_r$ kV	Continuous operating voltage $U_c$ kV	Arrester type	Designation	Nominal discharge current $I_n$ kA	Charge transfer rating $Q_{15}$ C	Thermal charge transfer rating $Q_{th}$ C	Maximum values of the residual voltages at discharge currents of the following impulses						
							30/60 $\mu$ s 125 A kV	30/60 $\mu$ s 500 A kV	8/20 $\mu$ s 1 kA kV	8/20 $\mu$ s 3 kA kV	8/20 $\mu$ s 5 kA kV	8/20 $\mu$ s 10 kA kV	8/20 $\mu$ s 20 kA kV
3.0	2.4	3EK7 030 - 4 C B 0	DH	10	0.5	1.1	5.8	6.1	6.5	7.1	7.4	8.0	9.1
6.0	4.8	3EK7 060 - 4 C B 0	DH	10	0.5	1.1	11.6	12.2	13.0	14.2	14.8	15.9	18.3
9.0	7.2	3EK7 090 - 4 C B 0	DH	10	0.5	1.1	17.4	18.4	19.6	21.2	22.2	23.9	27.4
12	9.6	3EK7 120 - 4 C C 0	DH	10	0.5	1.1	23.2	24.5	26.1	28.3	29.6	31.8	36.6
15	12.0	3EK7 150 - 4 C C 0	DH	10	0.5	1.1	29.0	30.6	32.6	35.4	37.0	39.8	45.7
18	14.4	3EK7 180 - 4 C D 0	DH	10	0.5	1.1	34.8	36.7	39.1	42.5	44.4	47.7	54.9
21	16.8	3EK7 210 - 4 C D 0	DH	10	0.5	1.1	40.6	42.9	45.6	49.5	51.8	55.7	64.0
24	19.2	3EK7 240 - 4 C E 0	DH	10	0.5	1.1	46.4	49.0	52.2	56.6	59.1	63.6	73.1
27	21.6	3EK7 270 - 4 C E 0	DH	10	0.5	1.1	52.2	55.1	58.7	63.7	66.5	71.6	82.3
30	24.0	3EK7 300 - 4 C F 0	DH	10	0.5	1.1	58.0	61.2	65.2	70.8	73.9	79.5	91.4
33	26.4	3EK7 330 - 4 C G 0	DH	10	0.5	1.1	63.8	67.3	71.7	77.8	81.3	87.5	101
36	28.8	3EK7 360 - 4 C H 0	DH	10	0.5	1.1	69.6	73.5	78.2	84.9	88.7	95.4	110
39	31.2	3EK7 390 - 4 C H 0	DH	10	0.5	1.1	75.4	79.6	84.7	92.0	96.1	103	119
42	33.6	3EK7 420 - 4 C H 0	DH	10	0.5	1.1	81.2	85.7	91.3	99.1	104	111	128
45	36.0	3EK7 450 - 4 C H 0	DH	10	0.5	1.1	87.1	91.8	97.8	106	111	119	137
48	38.4	3EK7 480 - 4 C H 0	DH	10	0.5	1.1	92.9	97.9	104	113	118	127	146
51	40.8	3EK7 510 - 4 C J 0	DH	10	0.5	1.1	98.7	104	111	120	126	135	155
54	43.2	3EK7 540 - 4 C J 0	DH	10	0.5	1.1	104	110	117	127	133	143	165
60	48.0	3EK7 600 - 4 C J 0	DH	10	0.5	1.1	116	122	130	142	148	159	183

#### Mechanical Characteristics

Height	Creepage distance	Rated short-circuit current	Lightning impulse withstand voltage	Power frequency withstand voltage, dry	Specified short-term load SSL	Specified long-term load SLL	Approximate weight of arrester without accessories	Flashover distance
[H] mm	mm	$I_s$ kA	1.2/50 $\mu$ s kV	1 min. kV	N	N	kg	mm
170	162	20	93	51	2940	2050	1.1	161
170	162	20	93	51	2940	2050	1.3	161
170	162	20	93	51	2940	2050	1.4	161
200	191	20	110	60	2500	1750	1.6	190
200	191	20	110	60	2500	1750	1.8	190
240	230	20	132	73	2080	1450	2.0	229
240	230	20	132	73	2080	1450	2.1	229
270	260	20	150	82	1850	1290	2.4	259
270	260	20	150	82	1850	1290	2.5	259
280	270	20	155	85	1780	1250	2.7	268
320	309	20	178	98	1560	1090	2.9	308
400	387	20	223	123	1250	870	3.3	386
400	387	20	223	123	1250	870	3.4	386
400	387	20	223	123	1250	870	3.6	386
400	387	20	223	123	1250	870	3.7	386
400	387	20	223	123	1250	870	3.9	386
470	456	20	263	145	1060	740	4.2	455
470	456	20	263	145	1060	740	4.2	455
470	456	20	263	145	1060	740	4.4	455

#### How to order

##### 3EK7 indoor IEC

##### Example 3EK7 360-4CH0

- 3EK7 ... Medium-voltage surge arrester
- 360 ... Rated voltage = 36 kV
- 4 ... LD class 1 [5 → LD class 2]
- C ... IEC
- H ... Housing type (H=400 mm)
- 0 ... Shedless

##### Example 3EK7 360-4CH0-Z M11 P12 M81

- Z ... is indicating accessories

##### Accessories:

- M11 ... Line clamp (M=Line terminal)
- M12 ... NEMA insulating bracket (M=Ground terminal)
- M81 ... Bird protection cap

#### Dimensions 3EK7 indoor IEC

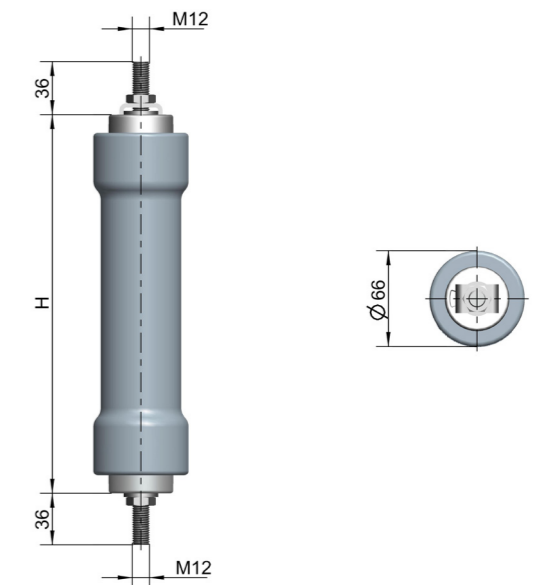

### 3EK7 SL indoor version according to IEC 60099-4 standard

Electrical Characteristics

Rated voltage $U_r$ kV	Continuous operating voltage $U_c$ kV	Arrester type	Designation	Nominal discharge current $I_n$ kA	Charge transfer rating $Q_{15}$ C	Thermal charge transfer rating $Q_{th}$ C	Maximum values of the residual voltages at discharge currents of the following impulses						
							30/60 $\mu$ s 125 A kV	30/60 $\mu$ s 500 A kV	8/20 $\mu$ s 1 kA kV	8/20 $\mu$ s 3 kA kV	8/20 $\mu$ s 5 kA kV	8/20 $\mu$ s 10 kA kV	8/20 $\mu$ s 20 kA kV
3.0	2.4	3EK7 030 - 5 C B 0	SL	10	1.2	4.5	6.2	6.6	7.0	7.6	8.0	8.6	9.8
6.0	4.8	3EK7 060 - 5 C B 0	SL	10	1.2	4.5	12.5	13.2	14.0	15.2	15.9	17.1	19.7
9.0	7.2	3EK7 090 - 5 C C 0	SL	10	1.2	4.5	18.7	19.8	21.0	22.8	23.9	25.7	29.5
12	9.6	3EK7 120 - 5 C D 0	SL	10	1.2	4.5	25.0	26.3	28.0	30.4	31.8	34.2	39.3
15	12.0	3EK7 150 - 5 C D 0	SL	10	1.2	4.5	31.2	32.9	35.1	38.0	39.8	42.8	49.2
18	14.4	3EK7 180 - 5 C E 0	SL	10	1.2	4.5	37.4	39.5	42.1	45.7	47.7	51.3	59.0
21	16.8	3EK7 210 - 5 C G 0	SL	10	1.2	4.5	43.7	46.1	49.1	53.3	55.7	59.9	68.8
24	19.2	3EK7 240 - 5 C H 0	SL	10	1.2	4.5	49.9	52.7	56.1	60.9	63.6	68.4	78.7
27	21.6	3EK7 270 - 5 C H 0	SL	10	1.2	4.5	56.2	59.3	63.1	68.5	71.6	77.0	88.5
30	24.0	3EK7 300 - 5 C H 0	SL	10	1.2	4.5	62.4	65.8	70.1	76.1	79.5	85.5	98.3
33	26.4	3EK7 330 - 5 C J 0	SL	10	1.2	4.5	68.7	72.4	77.1	83.7	87.5	94.1	108
36	28.8	3EK7 360 - 5 C J 0	SL	10	1.2	4.5	74.9	79.0	84.1	91.3	95.4	103	118
39	31.2	3EK7 390 - 5 C J 0	SL	10	1.2	4.5	81.1	85.6	91.1	98.9	103	111	128
42	33.6	3EK7 420 - 5 C K 0	SL	10	1.2	4.5	87.4	92.2	98.2	107	111	120	138

Mechanical Characteristics

Height	Creepage distance	Rated short-circuit current	Lightning impulse withstand voltage	Power frequency withstand voltage, dry	Specified short-term load SSL	Specified long-term load SLL	Approximate weight of arrester without accessories	Flashover distance
[H] mm	mm	$I_s$ kA	1.2/50 $\mu$ s kV	1 min. kV	N	N	kg	mm
170	162	20	93	51	2940	2050	1.1	161
170	162	20	93	51	2940	2050	1.2	161
200	191	20	110	60	2500	1750	1.6	190
240	230	20	132	73	2080	1450	1.9	229
240	230	20	132	73	2080	1450	2.1	229
270	260	20	150	82	1850	1290	2.4	259
320	309	20	178	98	1560	1090	2.7	308
400	387	20	223	123	1250	870	3.1	386
400	387	20	223	123	1250	870	3.3	386
400	387	20	223	123	1250	870	3.5	386
470	456	20	263	145	1060	740	3.9	455
470	456	20	263	145	1060	740	4.1	455
470	456	20	263	145	1060	740	4.3	455
510	495	20	286	157	980	680	4.6	494

#### How to order

##### 3EK7 SL indoor IEC

Example 3EK7 360-4CH0	
3EK7	... Medium-voltage surge arrester
360	... Rated voltage = 36 kV
4	... LD class 1 [5 → LD class 2]
C	... IEC
H	... Housing type (H=400 mm)
0	... Shedless
Example 3EK7 360-4CH0-Z M11 P12 M81	
-Z	... is indicating accessories
Accessories:	
M11	... Line clamp (M=Line terminal)
M12	... NEMA insulating bracket (M=Ground terminal)
M81	... Bird protection cap

#### Dimensions 3EK7 SL indoor IEC

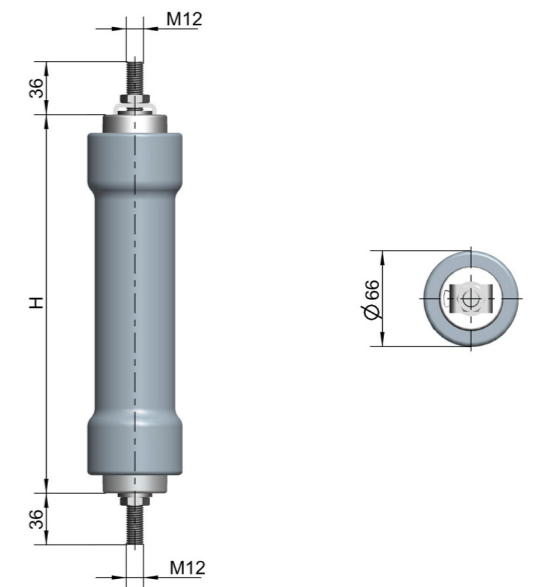

### 3EK7 indoor version specifications according to IEEE C62.11 standard

#### Electrical Characteristics

Duty cycle voltage kV	MCOV kV	Arrester order number	Energy class	Lightning impulse classifying current I <sub>n</sub> kA	Single impulse with-stand rating C	Switching surge energy rating kJ/kV <sub>MCOV</sub>	Protective Level Maximum discharge voltage						
							45/90µs 125 A kV cr	45/90µs 500 A kV cr	8/20µs 1.5 kA kV cr	8/20µs 3 kA kV cr	8/20µs 5 kA kV cr	8/20µs 10 kA kV cr	8/20µs 20 kA kV cr
3.0	2.55	3EK7 030 - 3 A B 0	B	10	0.5	4.5	6.9	7.3	8.1	8.5	8.8	9.5	10.9
3.0	2.55	3EK7 030 - 4 A B 0	B	10	0.5	4.5	5.8	6.1	6.8	7.1	7.4	8.0	9.2
6.0	5.10	3EK7 060 - 3 A B 0	B	10	0.5	4.5	14.3	15.1	16.7	17.4	18.2	19.6	22.5
6.0	5.10	3EK7 060 - 4 A B 0	B	10	0.5	4.5	11.6	12.3	13.6	14.2	14.8	15.9	18.3
9.0	7.65	3EK7 090 - 3 A B 0	B	10	0.5	4.5	20.5	21.6	23.9	25.0	26.1	28.1	32.3
9.0	7.65	3EK7 090 - 4 A B 0	B	10	0.5	4.5	17.5	18.4	20.3	21.3	22.2	23.9	27.5
10	8.40	3EK7 100 - 3 A B 0	B	10	0.5	4.5	21.5	22.6	25.0	26.2	27.3	29.4	33.8
10	8.40	3EK7 100 - 4 A C 0	B	10	0.5	4.5	19.4	20.5	22.6	23.7	24.7	26.6	30.6
12	10.2	3EK7 120 - 3 A C 0	B	10	0.5	4.5	27.2	28.7	31.7	33.2	34.7	37.3	42.9
12	10.2	3EK7 120 - 4 A D 0	B	10	0.5	4.5	23.3	24.6	27.1	28.4	29.7	31.9	36.7
15	12.7	3EK7 150 - 3 A D 0	B	10	0.5	4.5	34.0	35.9	39.6	41.5	43.3	46.6	53.6
15	12.7	3EK7 150 - 4 A D 0	B	10	0.5	4.5	29.1	30.7	33.9	35.5	37.1	39.9	45.9
18	15.3	3EK7 180 - 3 A D 0	B	10	0.5	4.5	40.8	43.0	47.5	49.8	52.0	55.9	64.3
18	15.3	3EK7 180 - 4 A E 0	B	10	0.5	4.5	34.9	36.8	40.7	42.6	44.5	47.8	55.0
21	17.0	3EK7 210 - 3 A E 0	B	10	0.5	4.5	44.7	47.1	52.0	54.5	56.9	61.2	70.4
21	17.0	3EK7 210 - 4 A F 0	B	10	0.5	4.5	40.7	43.0	47.4	49.7	51.9	55.8	64.2
24	19.5	3EK7 240 - 3 A F 0	B	10	0.5	4.5	51.5	54.3	59.9	62.7	65.6	70.5	81.1
24	19.5	3EK7 240 - 4 A H 0	B	10	0.5	4.5	46.6	49.1	54.2	56.8	59.3	63.8	73.4
27	22.0	3EK7 270 - 3 A G 0	B	10	0.5	4.5	58.2	61.4	67.7	70.9	74.1	79.7	91.7
27	22.0	3EK7 270 - 4 A H 0	B	10	0.5	4.5	52.4	55.3	61.0	63.9	66.7	71.8	82.5
30	24.4	3EK7 300 - 3 A H 0	B	10	0.5	4.5	64.1	67.6	74.6	78.1	81.7	87.8	101
30	24.4	3EK7 300 - 4 A H 0	B	10	0.5	4.5	58.2	61.4	67.8	71.0	74.2	79.7	91.7
33	27.5	3EK7 330 - 3 A H 0	B	10	0.5	4.5	71.8	75.8	83.6	87.6	91.5	98.4	113
33	27.5	3EK7 330 - 4 A J 0	B	10	0.5	4.5	64.0	67.5	74.6	78.1	81.6	87.7	101
36	29.0	3EK7 360 - 3 A H 0	B	10	0.5	4.5	78.8	83.2	91.8	96.1	100	108	124
36	29.0	3EK7 360 - 4 A K 0	B	10	0.5	4.5	69.9	73.7	81.3	85.2	89.0	95.7	110

#### Mechanical Characteristics

Height [H] inch	Leakage distance inch	Rated short-circuit current I <sub>s</sub> kA	Recommended minimum clearances		Maximum design cantilever load MDCL arrester only lbf	Specified short-term load SSL arrester only lbf	Approximate weight of arrester without accessories lbs
			To ground (ph-gnd) inch	Between phases (ph-ph) inch			
6.7	6.4	20	4	6	370	529	2.6
6.7	6.4	20	4	6	370	529	2.4
6.7	6.4	20	4	6	370	529	3.1
6.7	6.4	20	4	6	370	529	2.9
6.7	6.4	20	5	7	370	529	3.5
6.7	6.4	20	5	7	370	529	3.1
6.7	6.4	20	5	7	370	529	3.7
7.9	7.5	20	5	7	315	450	3.3
7.9	7.5	20	5	7	315	450	4.2
9.4	9.1	20	5	7	262	375	3.5
9.4	9.1	20	5	7	262	375	4.6
9.4	9.1	20	5	7	262	375	4.0
9.4	9.1	20	6	9	262	375	5.3
10.6	10.2	20	6	9	233	333	4.4
10.6	10.2	20	6	9	233	333	6.0
11.0	10.6	20	6	9	225	321	4.6
11.0	10.6	20	7	11	225	321	6.8
15.7	15.2	20	7	11	157	225	5.3
12.6	12.2	20	8	11	197	281	7.3
15.7	15.2	20	8	11	157	225	5.5
15.7	15.2	20	9	13	157	225	7.7
15.7	15.2	20	9	13	157	225	6.0
15.7	15.2	20	10	13	157	225	8.6
18.5	18.0	20	10	13	134	191	6.4
15.7	15.2	20	10	15	157	225	9.0
20.1	19.5	20	10	15	123	176	7.3

#### How to order

##### 3EK7 indoor IEEE

Example 3EK7 360-3AH0
3EK7 ... Medium-voltage surge arrester
360 ... Rated voltage = 36 kV
3 ... IEEE classification heavy duty
C ... IEEE
H ... Housing type (H=400 mm)
0 ... Shedless
Example 3EK7 360-3AH0-Z M11 P12 M81
-Z ... is indicating accessories
Accessoires:
M11 ... Line clamp (M=Line terminal)
P12 ... NEMA insulating bracket (M=Ground terminal)
M81 ... Bird protection cap

#### Dimensions 3EK7 indoor IEEE

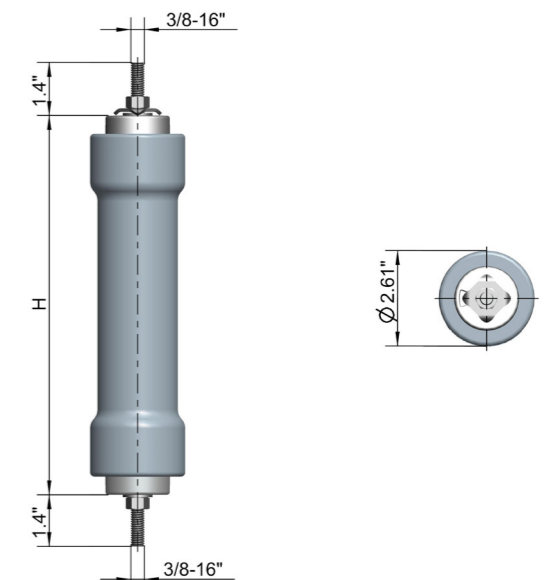

### 3EK8 according to IEC 60099-4 standard

Electrical Characteristics															Mechanical Characteristics										
Rated voltage	Continuous operating voltage	Arrester type	Designation	Nominal discharge current	Charge transfer rating	Thermal charge transfer rating	Maximum values of the residual voltages at discharge currents of the following impulses							Height [H]	Creepage distance	Rated short-circuit current	Housing insulation		Specified short-term load SSL		Specified long-term load SLL		Approximate weight of arrester without accessories	Flashover distance	Insulating bracket size
							30/60 μs	30/60 μs	8/20 μs	8/20 μs	8/20 μs	8/20 μs	8/20 μs				Lightning impulse withstand voltage	Power frequency withstand voltage	arrester only	with ins. bracket	arrester only	with ins. bracket			
kV	kV			I <sub>n</sub> kA	Q <sub>rs</sub> C	Q <sub>th</sub> C	125 A kV	500 A kV	1 kA kV	3 kA kV	5 kA kV	10 kA kV	20 kA kV	mm	mm	I <sub>s</sub> kA	1.2/50 μs kV	1 min., wet kV	N	N	N	N	kg	mm	
3.0	2.4	3EK8 030 - 1 C P 4	DH	10	0.4	1.1	5.9	6.2	6.5	7.1	7.4	8.0	8.9	97	267	20	63	29	2060	820	1440	570	0.5	109	short
6.0	4.8	3EK8 060 - 1 C P 4	DH	10	0.4	1.1	11.8	12.4	13.0	14.2	14.8	15.9	17.8	97	267	20	63	29	2060	820	1440	570	0.6	109	short
9.0	7.2	3EK8 090 - 1 C Q 4	DH	10	0.4	1.1	17.6	18.6	19.6	21.2	22.2	23.9	26.7	134	393	20	84	39	1490	590	1040	410	0.8	146	short
12	9.6	3EK8 120 - 1 C Q 4	DH	10	0.4	1.1	23.5	24.8	26.1	28.3	29.6	31.8	35.6	134	393	20	84	39	1490	590	1040	410	0.9	146	short
15	12.0	3EK8 150 - 1 C R 4	DH	10	0.4	1.1	29.4	31.0	32.6	35.4	37.0	39.8	44.5	153	465	20	95	44	1300	520	910	360	1.1	165	short
15	12.0	3EK8 150 - 1 C S 4	DH	10	0.4	1.1	29.4	31.0	32.6	35.4	37.0	39.8	44.5	180	578	20	111	51	1110	440	770	310	1.2	192	short
18	14.4	3EK8 180 - 1 C T 4	DH	10	0.4	1.1	35.3	37.2	39.1	42.5	44.4	47.7	53.4	240	765	20	146	68	830	330	580	230	1.6	252	long
21	16.8	3EK8 210 - 1 C T 4	DH	10	0.4	1.1	41.2	43.4	45.6	49.5	51.8	55.7	62.3	240	765	20	146	68	830	330	580	230	1.7	252	long
22	17.6	3EK8 220 - 1 C V 4	DH	10	0.4	1.1	43.1	45.5	47.8	51.9	54.2	58.3	65.3	295	997	20	178	82	670	270	470	180	2.0	307	long
24	19.2	3EK8 240 - 1 C V 4	DH	10	0.4	1.1	47.1	49.6	52.2	56.6	59.1	63.6	71.2	295	997	20	178	82	670	270	470	180	2.1	307	long
27	21.6	3EK8 270 - 1 C V 4	DH	10	0.4	1.1	52.9	55.8	58.7	63.7	66.5	71.6	80.1	295	997	20	178	82	670	270	470	180	2.1	307	long
30	24.0	3EK8 300 - 1 C V 4	DH	10	0.4	1.1	58.8	62.0	65.2	70.8	73.9	79.5	89.0	295	997	20	178	82	670	270	470	180	2.2	307	long
33	26.4	3EK8 330 - 1 C W 4	DH	10	0.4	1.1	64.7	68.2	71.7	77.8	81.3	87.5	97.9	332	1123	20	200	92	600	240	420	160	2.4	344	long
36	28.8	3EK8 360 - 1 C W 4	DH	10	0.4	1.1	70.6	74.4	78.2	84.9	88.7	95.4	107	332	1123	20	200	92	600	240	420	160	2.5	344	long
36	28.8	3EK8 360 - 1 C X 4	DH	10	0.4	1.1	70.6	74.4	78.2	84.9	88.7	95.4	107	390	1358	20	233	108	510	200	350	140	2.8	402	long

#### How to order

##### 3EK8 IEC

Example: 3EK8 360-1CW4	
3EK8	... Medium-voltage surge arrester
360	... Rated voltage = 36 kV
1C	... IEC
W	... Housing type (H=332 mm)
4	... Alternating sheds
Without -Z	... M12 internal thread
Example: 3EK8 360-1CW4 - Z M50 P50 M81	
-Z	... is indicating accessories
Accessoires:	
M50	... Bolt M12x53 (M = Line terminal)
P50	... Bolt M12x53 (P = Ground terminal)
M81	... Bird protection cap

#### Dimensions 3EK8 IEC

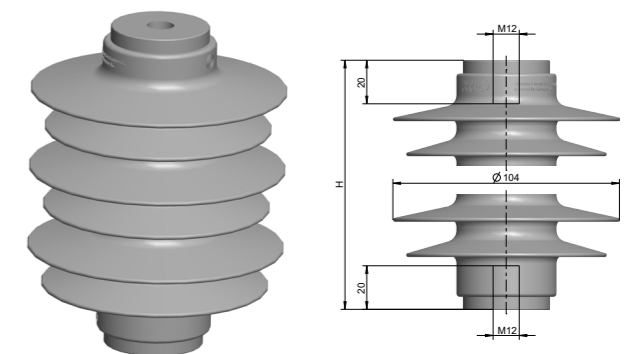

### 3EK8 HD according to IEEE C62.11 standard

Duty cycle voltage	MCOV	Arrester order number	Energy class	Electrical Characteristics											Mechanical Characteristics									
				Lightning impulse classifying current	Single-impulse charge transfer rating	Switching surge energy rating	Protective Level Maximum discharge voltage (crest)						Height [H]	Leakage distance	Rated short-circuit current	Recommended minimum clearances		Maximum design cantilever load MDCL		Specified short-term load SSL		Approximate weight of arrester without accessories	Insulating bracket	
							45/90 μs	45/90 μs	8/20 μs	8/20 μs	8/20 μs	8/20 μs				8/20 μs	To ground (ph-gnd)	Between phases (ph-ph)	arrester only	with ins. bracket	arrester only			with ins. bracket
kV	kV			I <sub>class</sub> kA	Q <sub>rs</sub> C	kJ / kV <sub>MCOV</sub>	125 A kV	500 A kV	1.5 kA kV	3 kA kV	5 kA kV	10 kA kV	20 kA kV	inches	inches	I <sub>s</sub> kA	inches	inches	lbf	lbf	lbf	lbf	lbs	size
3.0	2.55	3EK8 030 - 3 A B 4	A	10	0.4	3.0	6.7	7.0	7.7	8.0	8.4	9.0	10.1	3.2	7.1	20	3.0	4.3	384	154	548	219	2.3	short
6.0	5.10	3EK8 060 - 3 A C 4	A	10	0.4	3.0	13.3	14.0	15.3	16.0	16.7	18.0	20.2	5.2	13.0	20	3.4	5.4	237	95	338	135	3.0	short
9.0	7.65	3EK8 090 - 3 A C 4	A	10	0.4	3.0	20.0	21.1	23.0	24.0	25.1	27.0	30.2	5.2	13.0	20	4.0	6.0	237	95	338	135	3.1	short
10	8.40	3EK8 100 - 3 A C 4	A	10	0.4	3.0	22.2	23.4	25.5	26.7	27.9	30.0	33.6	5.2	13.0	20	4.2	6.2	237	95	338	135	3.2	short
12	10.2	3EK8 120 - 3 A E 4	A	10	0.4	3.0	26.6	28.1	30.6	32.0	33.5	36.0	40.3	7.5	20.5	20	5.5	7.5	165	66	235	94	4.2	short
15	12.7	3EK8 150 - 3 A E 4	A	10	0.4	3.0	33.3	35.1	38.3	40.1	41.9	45.0	50.4	7.5	20.5	20	6.5	8.5	165	66	235	94	4.4	short
18	15.3	3EK8 180 - 3 A E 4	A	10	0.4	3.0	40.0	42.1	45.9	48.1	50.2	54.0	60.5	7.5	20.5	20	7.5	9.5	165	66	235	94	4.5	long
21	17.0	3EK8 210 - 3 A G 4	A	10	0.4	3.0	46.6	49.1	53.6	56.1	58.6	63.0	70.6	10.2	28.7	20	8.0	10.0	121	48	173	69	5.5	long
24	19.5	3EK8 240 - 3 A G 4	A	10	0.4	3.0	53.3	56.2	61.2	64.1	67.0	72.0	80.6	10.2	28.7	20	10.0	12.0	121	48	173	69	5.6	long
27	22.0	3EK8 270 - 3 A G 4	A	10	0.4	3.0	59.9	63.2	68.9	72.1	75.3	81.0	90.7	10.2	28.7	20	10.8	13.0	121	48	173	69	5.7	long
30	24.4	3EK8 300 - 3 A J 4	A	10	0.4	3.0	66.6	70.2	76.5	80.1	83.7	90.0	101	12.7	36.6	20	10.8	13.3	98	39	140	56	6.6	long
36	29.0	3EK8 360 - 3 A J 4	A	10	0.4	3.0	79.9	84.2	91.8	96.1	100.4	108.0	121	12.7	36.6	20	12.8	16.3	98	39	140	56	6.9	long

#### How to order

##### 3EK8 HD IEEE

Example 3EK8 360-3AJ4	
3EK8	... Medium-voltage surge arrester
360	... Rated voltage = 36 kV
3	... IEEE classification heavy duty
A	... IEEE
J	... Housing type (H=322 mm)
4	... Alternating sheds
Example 3EK8 360-3AJ4-Z M11 P12 M81	
-Z	... is indicating accessories
Accessoires:	
M11	... Line clamp (M=Line terminal)
P12	... NEMA insulating bracket (M=Ground terminal)
M81	... Bird protection cap

#### Dimensions 3EK8 HD IEEE

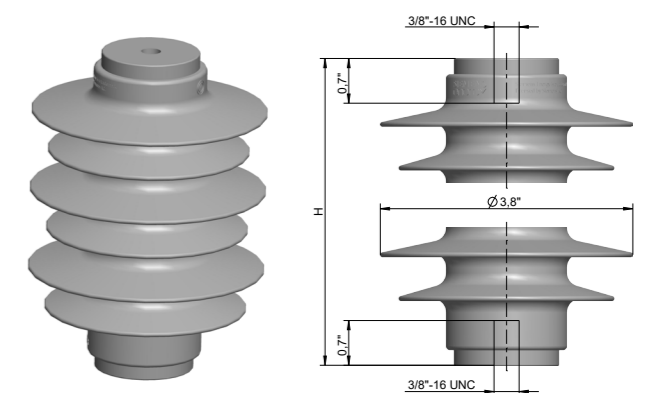

### 3EK8 RP according to IEEE C62.11 standard

Duty cycle voltage	MCOV	Arrester order number	Electrical Characteristics													Mechanical Characteristics									
			Lightning impulse classifying current	Single-impulse charge transfer rating	Switching surge energy rating	Protective Level Maximum discharge voltage (crest)						Height [H]	Leakage distance	Rated short-circuit current	Recommended minimum clearances		Maximum design cantilever load MDCL		Specified short-term load SSL		Approximate weight of arrester without accessories	Insulating bracket			
						45/90 μs	45/90 μs	8/20 μs	8/20 μs	8/20 μs	8/20 μs				To ground (ph-gnd)	Between phases (ph-ph)	arrester only	with ins. bracket	arrester only	with ins. bracket					
kV	kV		I <sub>class</sub> kA	Q <sub>rs</sub> C	kJ / kV <sub>MCOV</sub>	125 A kV	500 A kV	1.5 kA kV	3 kA kV	5 kA kV	10 kA kV	20 kA kV	inches	inches	I <sub>s</sub> kA	inches	inches	lbf	lbf	lbf	lbf	lbs	size		
3.0	2.55	3EK8 030 - 4 A C 4	10	0.4	3.0	6.7	7.1	7.7	8.1	8.5	9.1	10.2	5.2	13.0	20	3.0	4.3	237	95	338	135	2.9	short		
6.0	5.10	3EK8 060 - 4 A C 4	10	0.4	3.0	13.5	14.2	15.5	16.2	16.9	18.2	20.4	5.2	13.0	20	3.4	5.4	237	95	338	135	3.0	short		
9.0	7.65	3EK8 090 - 4 A E 4	10	0.4	3.0	18.0	19.0	20.7	21.6	22.6	24.3	27.2	7.5	20.5	20	4.0	6.0	165	66	235	94	4.0	short		
10	8.40	3EK8 100 - 4 A E 4	10	0.4	3.0	19.8	20.9	22.8	23.9	24.9	26.8	30.0	7.5	20.5	20	4.2	6.2	165	66	235	94	4.1	short		
12	10.2	3EK8 120 - 4 A E 4	10	0.4	3.0	23.6	24.9	27.1	28.4	29.7	31.9	35.7	7.5	20.5	20	5.5	7.5	165	66	235	94	4.2	short		
15	12.7	3EK8 150 - 4 A G 4	10	0.4	3.0	30.0	31.6	34.4	36.0	37.7	40.5	45.4	10.2	28.7	20	6.5	8.5	121	48	173	69	5.1	short		
18	15.3	3EK8 180 - 4 A G 4	10	0.4	3.0	36.0	37.9	41.3	43.3	45.2	48.6	54.4	10.2	28.7	20	7.5	9.5	121	48	173	69	5.3	long		
21	17.0	3EK8 210 - 4 A J 4	10	0.4	3.0	41.0	43.2	47.1	49.3	51.5	55.4	62.0	12.7	36.6	20	8.0	10.0	98	39	140	56	6.1	long		
24	19.5	3EK8 240 - 4 A J 4	10	0.4	3.0	47.2	49.8	54.2	56.8	59.3	63.8	71.5	12.7	36.6	20	10.0	12.0	98	39	140	56	6.2	long		
27	22.0	3EK8 270 - 4 A J 4	10	0.4	3.0	53.1	56.0	61.0	63.9	66.8	71.8	80.4	12.7	36.6	20	10.8	13.0	98	39	140	56	6.4	long		

#### How to order

##### 3EK8 RP IEEE

Example 3EK8 360-3AJ4	
3EK8	... Medium-voltage surge arrester
360	... Rated voltage = 36 kV
3	... IEEE classification heavy duty
A	... IEEE
J	... Housing type (H=322 mm)
4	... Alternating sheds
Example 3EK8 360-3AJ4-Z M11 P12 M81	
-Z	... is indicating accessories
Accessoires:	
M11	... Line clamp (M=Line terminal)
P12	... NEMA insulating bracket (M=Ground terminal)
M81	... Bird protection cap

#### Dimensions 3EK8 RP IEEE

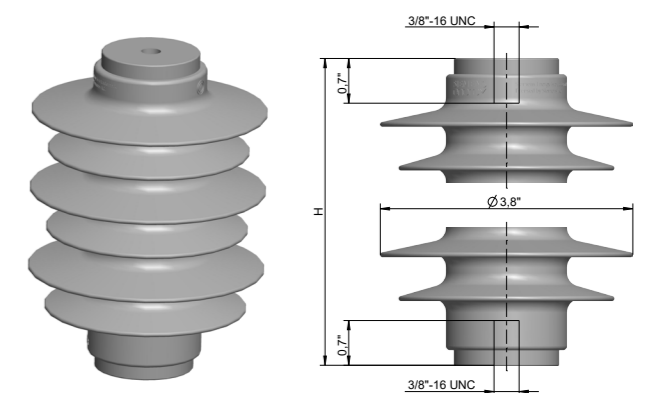

## 3EK Accessories

### Line terminal options

#### [M11] Line Clamp $\varnothing 8$ mm ... $\varnothing 18$ mm

Order number spare part: for thread 3/8": 3EX4 063-0A / for thread M12: 3EX4 063-0C

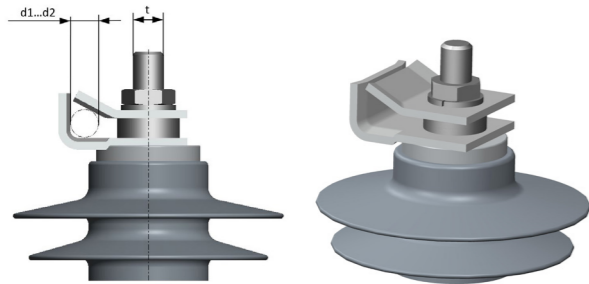

For surge arrester: 3EK7 and 3EK8

	IEC	IEEE
d1	8 mm	0.32"
d2	18 mm	0.70"
t	M12	3/8 - 16"

#### [M12] L-bracket

Order number spare part: for thread M12: 3EX4 071

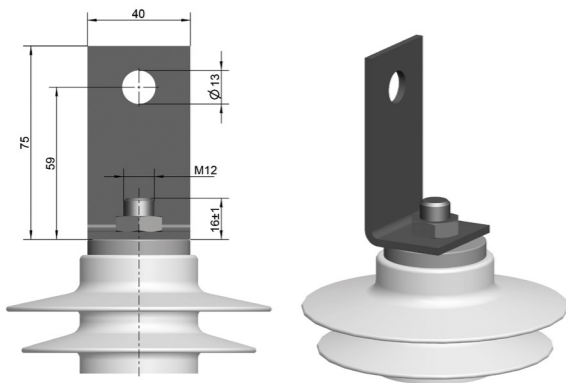

For surge arrester 3EK7 and 3EK8

	IEC	IEEE
a	59 mm	-
b	40 mm	-
h	75 mm	-
d1	13 mm	-

#### [M13] Line clamp $\varnothing 8$ mm ... $\varnothing 18$ mm

Order number spare part: for thread 3/8": 3EX4 101-1A / for thread M12: 3EX4 101-1C

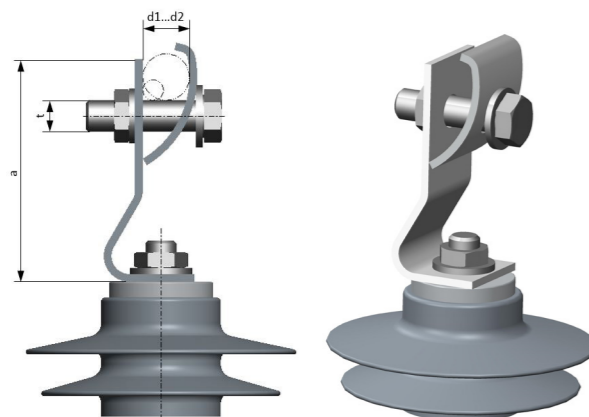

For surge arrester 3EK7 and 3EK8

	IEC	IEEE
a	86 mm	3.39"
d1	8 mm	0.32"
d2	18 mm	0.70"
t	M 12	3/8 - 16"

### Bird protection cap options

#### [M81] Bird protection cap

Order number spare part: 3EX4 128-0A

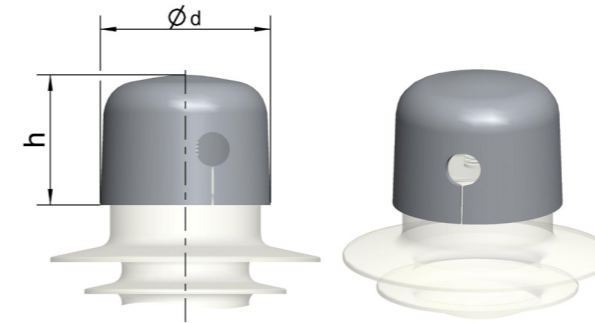

For surge arrester: 3EK7

	IEC	IEEE
d	75 mm	2.95"
h	57 mm	2.25"

#### [M81] Bird protection cap

Order number spare part: 3EX4 068-0C

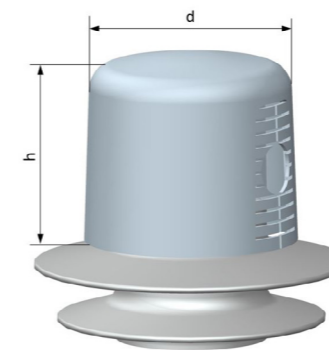

For surge arrester: 3EK8

	IEC	IEEE
d	65 mm	2.56"
h	57.2 mm	2.25"

#### [M84] Bird protection cap XL

Order number spare part: 3EX4 103

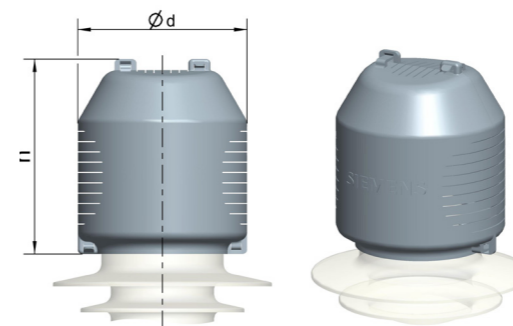

For surge arrester: 3EK7

	IEC	IEEE
d	92 mm	3.62"
h	106 mm	4.17"

## Metal bracket options

### [P11] NEMA metal bracket

Order number spare part: for thread 3/8": 3EX4 061-0A / for thread M12: 3EX4 061-0C

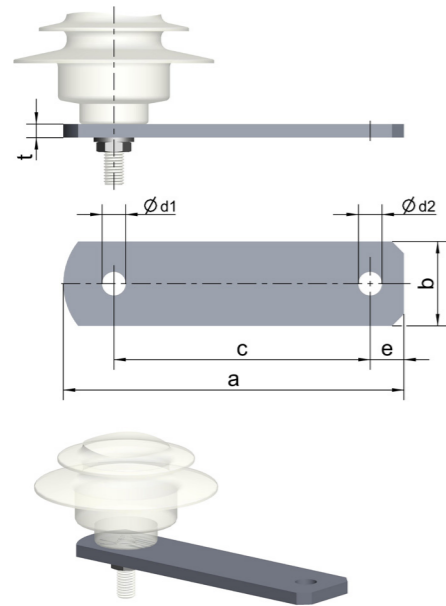

For surge arrester 3EK7 and 3EK8

	IEC	IEEE
a	202 mm	7.95"
b	50 mm	1.97"
c	152 mm	5.98"
e	20 mm	0.79"
d1	14 mm	0.55"
d2	14 mm	0.55"
t	8 mm	0.32"

### [P21] DIN metal bracket

Order number spare part: 3EX4 062

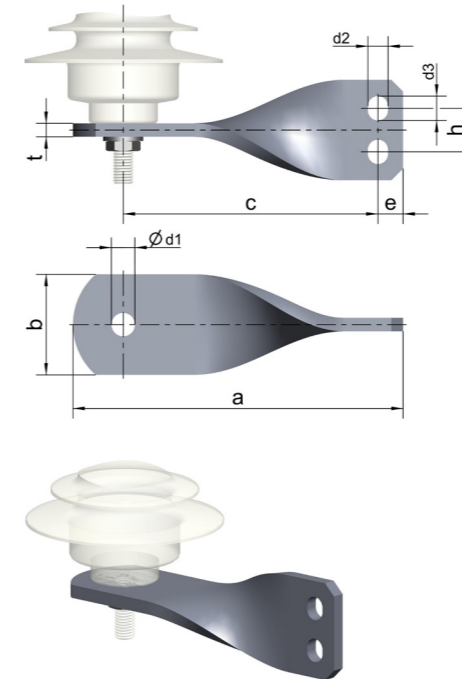

For surge arrester 3EK7 and 3EK8

	IEC	IEEE
a	197 mm	7.76"
b	60 mm	2.36"
c	152 mm	5.98"
e	15 mm	0.59"
d1	14 mm	0.55"
d2	12 mm	0.47"
d3	14.5 mm	0.57"
h	26 mm	1.02"
t	8 mm	0.32"

## Insulating bracket options

### [P12] NEMA insulating bracket for $U_r \leq 15$ kV

Order number spare part: for thread 3/8": 3EX4 080-1A / for thread M12: 3EX4 080-1C

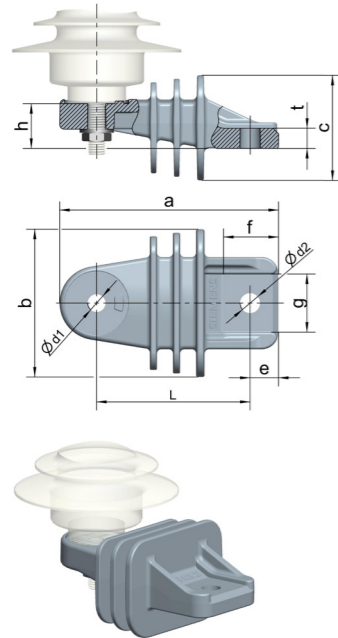

For surge arrester **3EK7**

	IEC	IEEE
a	154 mm	6.06"
b	104 mm	4.1"
c	74 mm	2.91"
e	20 mm	0.79"
f	40 mm	1.58"
g	41 mm	1.61"
h	31,5 mm	1.24"
d1	12,5 mm	3/8"
d2	14 mm	1/2"
l	108 mm	4.25"
t	14,2 mm	0.56"

## Insulating bracket options

### [P12] NEMA insulating bracket for $U_r \leq 15$ kV

Order number spare part: for thread 3/8": 3EX4 120-1A / for thread M12: 3EX4 120-1C

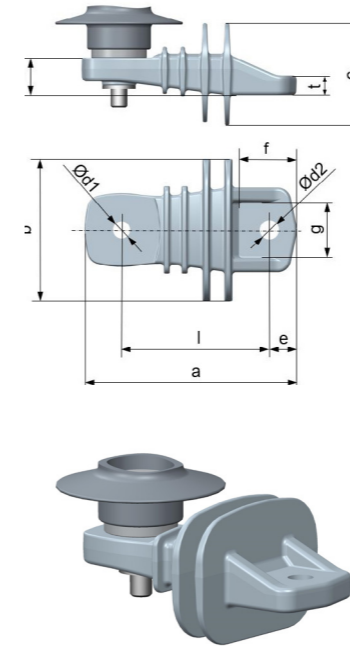

For surge arrester **3EK8**

	IEC	IEEE
a	155 mm	6.1"
b	104 mm	4.09"
c	73.8 mm	2.9"
e	19.8 mm	0.78"
f	41 mm	1.61"
g	41 mm	1.61"
h	27 mm	1.06"
d1	10.5 mm	3/8"
d2	14 mm	1/2"
l	108 mm	4.25"

### [P12] NEMA insulating bracket for $U_r > 15$ kV

Order number spare part: for thread 3/8": 3EX4 080-2A / for thread M12: 3EX4 080-2C

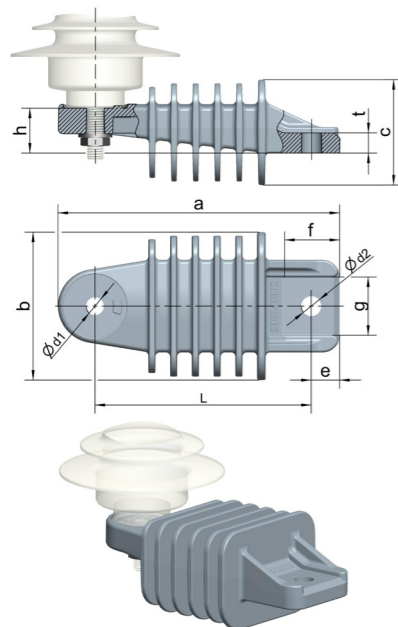

For surge arrester **3EK7**

	IEC	IEEE
a	198 mm	7.8"
b	104 mm	4.1"
c	74 mm	2.91"
e	20 mm	0.79"
f	40 mm	1.58"
g	41 mm	1.61"
h	31.5 mm	1.24"
d1	12.5 mm	3/8"
d2	14 mm	1/2"
l	152 mm	6.0"
t	14.2 mm	0.56"

### [P12] NEMA insulating bracket for $U_r > 15$ kV

Order number spare part: for thread 3/8": 3EX4 120-2A / for thread M12: 3EX4 120-2C

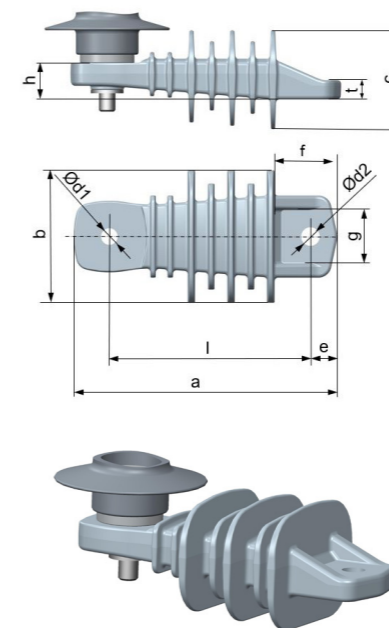

For surge arrester **3EK8**

	IEC	IEEE
a	199 mm	7.83"
b	100 mm	3.94"
c	72.9 mm	2.87"
e	19.8 mm	0.78"
f	41 mm	1.61"
g	41 mm	1.61"
h	27 mm	1.06"
d1	10.5 mm	3/4"
d2	14 mm	1/2"
l	152 mm	5.98"

## Insulating bracket options

### [P22] DIN insulating bracket for $U_r \leq 15$ kV

Order number spare part: for thread M12: 3EX4 086-1C

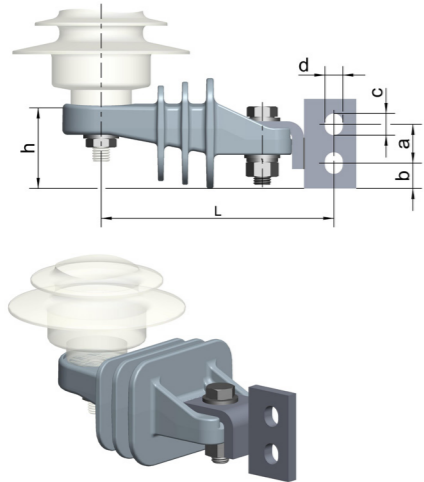

For surge arrester: 3EK7

	IEC	IEEE
a	26 mm	1.02"
b	17 mm	0.67"
c	14.5 mm	0.57"
d	12 mm	0.47"
h	54 mm	2.13"
l	156 mm	6.14"

### [P22] DIN insulating bracket for $U_r > 15$ kV

Order number spare part: for thread M12: 3EX4 086-2C

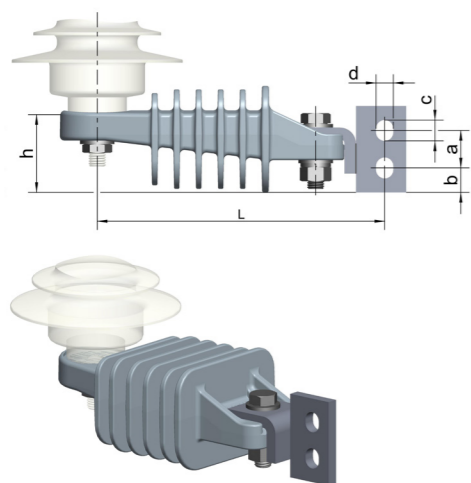

For surge arrester: 3EK7

	IEC	IEEE
a	26 mm	1.02"
b	17 mm	0.67"
c	14.5 mm	0.57"
d	12 mm	0.47"
h	54 mm	2.13"
l	200 mm	7.87"

## Disconnecter options

Ground lead disconnectors operate after arrester failures, to avoid permanent ground faults in the network. Most disconnectors on the market contain explosive cartridges to operate the disconnector; these cartridges are considered as dangerous goods with certain risks (violent shattering, acoustic shock), and are strongly regulated in most countries. Siemens Energy disconnectors do not utilize any pyrotechnics – offering safe handling, storage and installation.

### Disconnecter for surge arrester 3EK7

Order number spare part: for thread 3/8": 3EX4 065-7A / for thread M12: 3EX4 065-7C



### Disconnecter for surge arrester 3EK8

Order number spare part: for thread 3/8": 3EX4 065-8 / for thread M12: 3EX4 065-8C

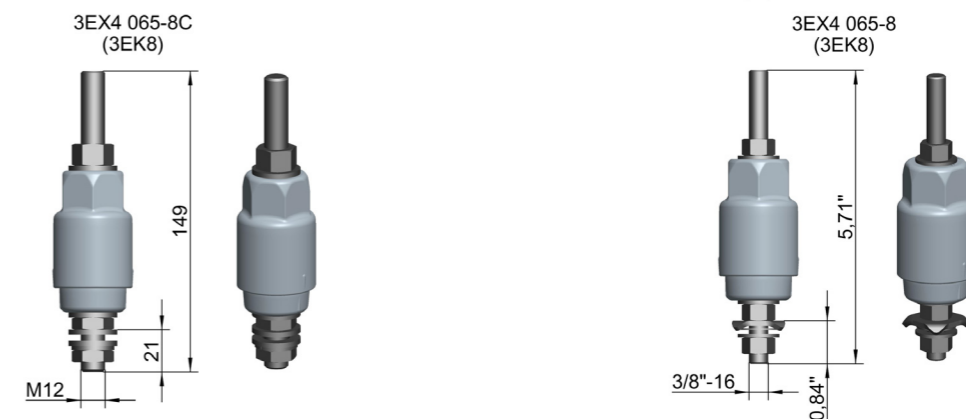

## Mounting options

### Transformer bracket

#### [Q11] 8.7 inch / 221 mm

Order number spare part: 3EX4 075-0A

For surge arrester: 3EK7 and 3EK8

	IEC	IEEE
a	221 mm	8 5/8 "
b	60.5 mm	2 3/8 "
c	8 mm	0.32 "
d	14.3 mm	0.56 "
e	40 mm	1.58 "
f	41.4 mm	1 5/8 "
g	63.2 mm	2 1/2 "
h	57.2 mm	2 1/4 "

#### [Q12] 11 inch / 279 mm

Order number spare part: 3EX4 075-0C

For surge arrester: 3EK7 and 3EK8

	IEC	IEEE
a	279.4 mm	11 "
b	60.5 mm	2 3/8 "
c	8 mm	0.32 "
d	14.3 mm	0.56 "
e	40 mm	1.58 "
f	41.4 mm	1 5/8 "
g	63.2 mm	2 1/2 "
h	57.2 mm	2 1/4 "

#### [Q13] 12.25 inch / 311 mm

Order number spare part: 3EX4 075-0B

For surge arrester: 3EK7 and 3EK8

	IEC	IEEE
a	311.2 mm	12 1/4 "
b	60.5 mm	2 3/8 "
c	8 mm	0.32 "
d	14.3 mm	0.56 "
e	40 mm	1.58 "
f	41.4 mm	1 5/8 "
g	63.2 mm	2 1/2 "
h	57.2 mm	2 1/4 "

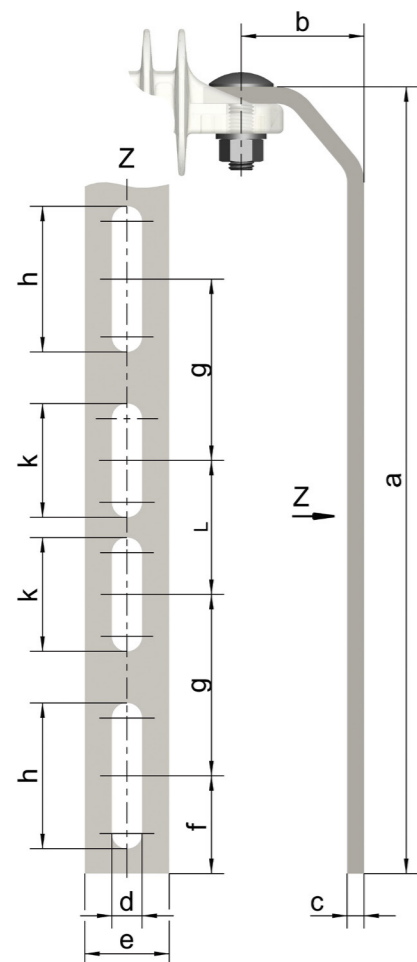

#### [Q14] Transformer bracket, 14.5 inch / 368 mm

Order number spare part: 3EX4 075-0D

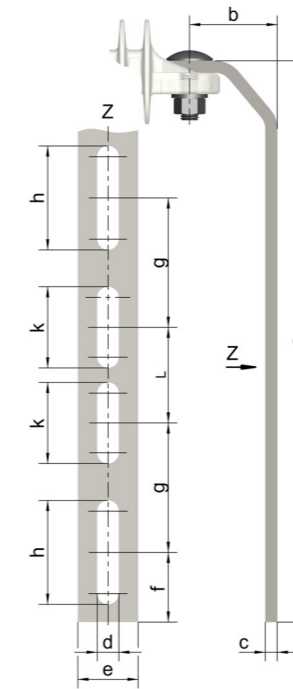

For surge arrester: 3EK7 and 3EK8

	IEC	IEEE
a	368.3 mm	14 1/4 "
b	58.2 mm	2.3 "
c	8 mm	0.32 "
d	14.3 mm	0.56 "
e	40 mm	1.58 "
f	46.3 mm	1.82 "
g	85.9 mm	3 3/8 "
h	69 mm	2 3/4 "
k	53.9 mm	2 1/8 "
l	63.5 mm	2 1/2 "

#### [Q51] Cross-arm bracket

Order number spare part: 3EX4 073-0A

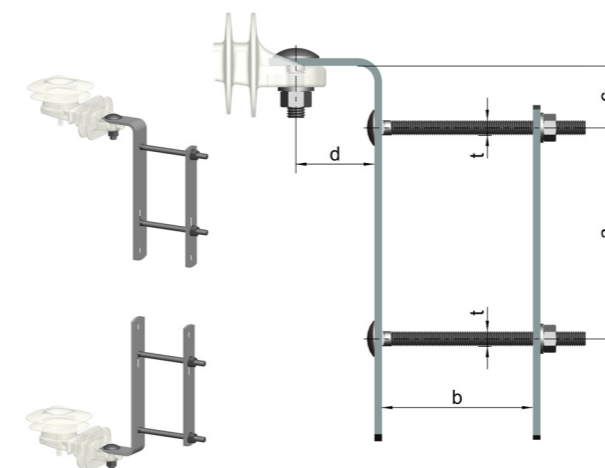

For surge arrester: 3EK7 and 3EK8

	IEC	IEEE
a	104,6 ... 150.9 mm	4.12" ... 5.94"
b	0 ... 120.6 mm	0" ... 4.75"
c	33 mm	1.30"
d	52 mm	2.05"
t	M10	M10

## Lead options

### [P52] Ground strap, 305 mm / 12 inch

Order number spare part: for thread 3/8": 3EX4 078-0A / for thread M12: 3EX4 078-0C

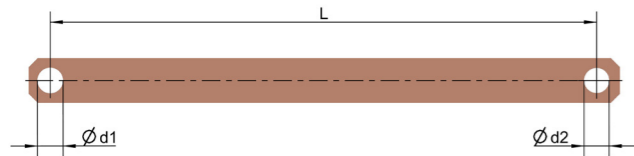

For surge arrester: 3EK7 and 3EK8

	ICE	IEEE
L	305 mm	12"
d1	14 mm	3/8"
d2	14 mm	1/2"

### [R51] Line and earth lead, insulated

Order number spare part: for thread 3/8": 3EX4 074-0A / for thread M12: 3EX4 074-0C

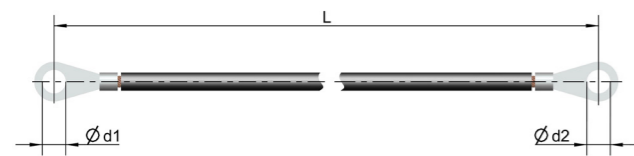

For surge arrester: 3EK7 and 3EK8

	IEC	IEEE
L	455 mm	17.9"
d1	13 mm	3/8"
d2	13 mm	1/2"

### [R61] Line and earth lead

Order number spare part: for thread 3/8": 3EX4 121-3A

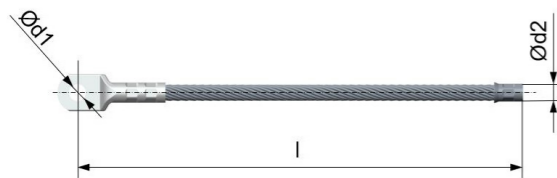

For surge arrester: 3EK7 and 3EK8

	IEEE
d1	3/8"
d2	1"
l	12"

## Packing dimensions 3EK

Arrester type	Housing size	Pcs per pallet	Pcs per container		Box dimension / mm		
			20'	40'	L	W	H
3EK7 IEC	B	108	2160	4320	300	220	145
	C	108	2160	4320	300	220	145
	D	90	1800	3600	345	220	145
	E	90	1800	3600	375	220	145
	F	72	1440	2880	410	220	145
	H	60	1200	2400	498	220	145
	J	48	960	1920	605	220	145

Arrester type	Housing size	Pcs per pallet	Pcs per container		Box dimension / mm		
			20'	40'	L	W	H
3EK7 IEEE	B	80	1600	3200	455	135	240
	C	80	1600	3200	455	135	240
	D	72	1440	2880	485	135	240
	E	64	1280	2560	565	135	240
	F	64	1280	2560	565	135	240
	H	48	960	1920	645	135	240
	J	40	800	1600	755	135	240
K	40	800	1600	755	135	240	

Arrester type	Housing size	Pcs per pallet	Pcs per container		Box dimension / mm		
			20'	40'	L	W	H
3EK8 IEC	P	136	2720	5440	290	120	230
	Q	104	2080	4160	345	120	230
	R	104	2080	4160	345	120	230
	S	100	2000	4000	385	120	230
	T	80	1600	3200	455	120	230
	U	80	1600	3200	455	120	230
	V	80	1600	3200	485	120	230
	W	64	1280	2560	525	120	230
	X	64	1280	2560	580	120	230

Arrester type	Housing size	Pcs per pallet	Pcs per container		Box dimension / mm		
			20'	40'	L	W	H
3EK8 IEEE	B	136	2720	5440	290	120	230
	C	104	2080	4160	345	120	230
	E	100	2000	4000	385	120	230
	G	80	1600	3200	455	120	230
	J	64	1280	2560	525	120	230

# 3EH4 medium-voltage surge arresters for distribution networks

The 3EH4 medium-voltage plug-in arrester optimally protects your transformers and switchgear (indoor & outdoor IP66) against switching overvoltages and lightning. Thanks to the alignment of the arrester's protection performance with the impulse withstand voltage of encapsulated switchgear and transformers, overvoltages generated by the reflection of traveling waves and switching operations are also limited.

Because it has the same electrical characteristics as Siemens Energy' 3EK medium-voltage surge arresters, the 3EH4 medium-voltage surge arrester also offers extremely reliable protection against overvoltages.

New versions with insulated ground terminal are available, enabling the use of monitoring devices.

## Rugged design for high power and a long life

The plug-and-socket connection is available in connector sizes 2 and 3 and is dimensioned to EN 50180/EN 50181 for the inner cone system. The 3EH4 medium-voltage surge arrester corresponds to arrester class DH and is suitable for operating voltages up to 52.5 kV. Low residual voltages

guarantee superior insulation coordination and protection. The metal-oxide resistors (MOVs) are silicone-coated, providing insulation against the metal housing. A corresponding dimensioning ensures that the metal-oxide resistors have the requisite thermal stability. However, if the MOVs should be overloaded, the 3EH4 medium-voltage surge arrester provides a controlled reduction in pressure via a corrosion-resistant pressure-relief diaphragm.

The 3EH4 medium-voltage surge arrester protects personnel by means of a grounded, corrosion-resistant aluminum housing, making it touch-proof. Because it is hermetically sealed, the MOVs are also protected against moisture and other environmental influences.

## Development according to standards

The 3EH4 surge arrester complies with the IEC 60099-4 standard. The connector system was dimensioned according to the EN 50180 and EN 50181 standards. Type tests were performed in independent, PEHLA-accredited laboratories; the reports are available on request from your Siemens Energy contact.



Siemens Energy 3EH4 surge arresters are ideally suited for the reliable protection of:

- Switchgear protection
- Transformer protection

## 3EH4 – connector size 2

Electrical Characteristics

Mechanical Characteristics

Rated voltage	Continuous operating voltage	Arrester type		Designation	Nominal discharge current	Charge transfer rating	Thermal charge transfer rating	Maximum values of the residual voltages at discharge currents of the following impulses					Height	Rated short-circuit current	Housing insulation		Approximate weight of arrester	Dimensioned drawing			
								Lightning impulse withstand voltage 1.2/50 μs	Power-frequency withstand voltage 1 min.												
$U_r$ kV	$U_c$ kV				$I_n$ kA	$Q_{rs}$ C	$Q_{th}$ C	30/60 μs 125 A kV	30/60 μs 500 A kV	8/20 μs 1 kA kV	8/20 μs 3 kA kV	8/20 μs 5 kA kV	8/20 μs 10 kA kV	8/20 μs 20 kA kV	H mm	$I_s$ kA	kV	kV	kg		
7.5	6.0	3EH4	075	- 1 B C 1 4	DH	10	0.4	1.1	14.5	15.3	16.3	17.7	18.5	19.9	22.9	335	16	200	70	4.4	B
9.0	7.2	3EH4	090	- 1 B C 1 4	DH	10	0.4	1.1	17.4	18.4	19.6	21.2	22.2	23.9	27.4	335	16	200	70	4.4	B
12.5	10.0	3EH4	125	- 1 B C 1 4	DH	10	0.4	1.1	24.2	25.5	27.2	29.5	30.8	33.1	38.1	335	16	200	70	4.4	B
15.0	12.0	3EH4	150	- 1 B C 1 4	DH	10	0.4	1.1	29.0	30.6	32.6	35.4	37.0	39.8	45.7	335	16	200	70	4.4	B
17.5	14.0	3EH4	175	- 1 B C 1 4	DH	10	0.4	1.1	33.9	35.7	38.0	41.3	43.1	46.4	53.3	335	16	200	70	4.5	B
19.0	15.2	3EH4	190	- 1 B C 1 4	DH	10	0.4	1.1	36.8	38.8	41.3	44.8	46.8	50.4	57.9	335	16	200	70	4.5	B
21.5	17.2	3EH4	215	- 1 B C 1 4	DH	10	0.4	1.1	41.6	43.9	46.7	50.7	53.0	57.0	65.5	335	16	200	70	4.6	B
24.0	19.2	3EH4	240	- 1 B C 1 4	DH	10	0.4	1.1	46.4	49.0	52.2	56.6	59.1	63.6	73.1	335	16	200	70	4.6	B
30.0	24.0	3EH4	300	- 1 B C 1 4	DH	10	0.4	1.1	58.0	61.2	65.2	70.8	73.9	79.5	91.4	335	16	200	70	4.7	B
36.0	28.8	3EH4	360	- 1 B C 1 4	DH	10	0.4	1.1	69.6	73.5	78.2	84.9	88.7	95.4	109.7	335	16	200	70	4.8	B
45.0	36.0	3EH4	450	- 1 C C 1 4	DH	10	0.4	1.1	87.1	91.8	97.8	106.1	110.9	119.3	137	466	16	220	100	6.5	C
51.0	40.8	3EH4	510	- 1 C C 1 4	DH	10	0.4	1.1	98.7	104.1	110.8	120.3	125.7	135.2	155	466	16	220	100	6.6	C
52.5	42.0	3EH4	525	- 1 C C 1 4	DH	10	0.4	1.1	101.6	107.1	114.1	123.8	129.4	139.1	160	466	16	220	100	6.6	C

### How to order

#### 3EH4, earthed housing

Example 3EH4 300-1BC14	
3EH4	... Plug-in arrester connector size 2
300	... Rated voltage = 30 kV
-1	... Connector size 2
B	... Housing size 1, earthed (H=335 mm)
C	... MO resistor type
1	... Indoor application
4	... Protection class IP66

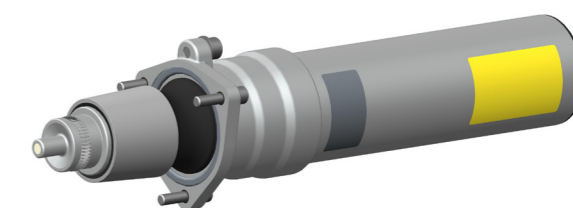

### 3EH4 – connector size 2 - insulated

Electrical Characteristics

Mechanical Characteristics

Rated voltage	Continuous operating voltage	Electrical Characteristics											Mechanical Characteristics							
		Arrester type		Designation	Nominal discharge current	Charge transfer rating	Thermal charge transfer rating	Maximum values of the residual voltages at discharge currents of the following impulses					Height	Rated short-circuit current	Housing insulation		Approximate weight of arrester	Dimensioned drawing		
$U_r$ kV	$U_c$ kV									30/60 $\mu$ s 125 A kV	30/60 $\mu$ s 500 A kV	8/20 $\mu$ s 1 kA kV			8/20 $\mu$ s 3 kA kV	8/20 $\mu$ s 5 kA kV			8/20 $\mu$ s 10 kA kV	8/20 $\mu$ s 20 kA kV
7.5	6.0	3EH4	075 - 1 J C 1 4	DH	10	0.4	1.1	14.5	15.3	16.3	17.7	18.5	19.9	22.9	335	16	200	70	4.4	J
9.0	7.2	3EH4	090 - 1 J C 1 4	DH	10	0.4	1.1	17.4	18.4	19.6	21.2	22.2	23.9	27.4	335	16	200	70	4.4	J
12.5	10.0	3EH4	125 - 1 J C 1 4	DH	10	0.4	1.1	24.2	25.5	27.2	29.5	30.8	33.1	38.1	335	16	200	70	4.4	J
15.0	12.0	3EH4	150 - 1 J C 1 4	DH	10	0.4	1.1	29.0	30.6	32.6	35.4	37.0	39.8	45.7	335	16	200	70	4.4	J
17.5	14.0	3EH4	175 - 1 J C 1 4	DH	10	0.4	1.1	33.9	35.7	38.0	41.3	43.1	46.4	53.3	335	16	200	70	4.5	J
19.0	15.2	3EH4	190 - 1 J C 1 4	DH	10	0.4	1.1	36.8	38.8	41.3	44.8	46.8	50.4	57.9	335	16	200	70	4.5	J
21.5	17.2	3EH4	215 - 1 J C 1 4	DH	10	0.4	1.1	41.6	43.9	46.7	50.7	53.0	57.0	65.5	335	16	200	70	4.6	J
24.0	19.2	3EH4	240 - 1 J C 1 4	DH	10	0.4	1.1	46.4	49.0	52.2	56.6	59.1	63.6	73.1	335	16	200	70	4.6	J
30.0	24.0	3EH4	300 - 1 J C 1 4	DH	10	0.4	1.1	58.0	61.2	65.2	70.8	73.9	79.5	91.4	335	16	200	70	4.7	J
36.0	28.8	3EH4	360 - 1 J C 1 4	DH	10	0.4	1.1	69.6	73.5	78.2	84.9	88.7	95.4	109.7	335	16	200	70	4.8	J
45.0	36.0	3EH4	450 - 1 K C 1 4	DH	10	0.4	1.1	87.1	91.8	97.8	106.1	110.9	119.3	137	466	16	220	100	6.5	K
51.0	40.8	3EH4	510 - 1 K C 1 4	DH	10	0.4	1.1	98.7	104.1	110.8	120.3	125.7	135.2	155	466	16	220	100	6.6	K
52.5	42.0	3EH4	525 - 1 K C 1 4	DH	10	0.4	1.1	101.6	107.1	114.1	123.8	129.4	139.1	160	466	16	220	100	6.6	K

#### How to order

##### 3EH4, insulated housing

Example 3EH4 300-1JC14	
3EH4	... Plug-in arrester connector size 2
300	... Rated voltage = 30 kV
-1	... Connector size 2
J	... Housing size 1, insulated (H=335 mm)
C	... MO resistor type
1	... Indoor application
4	... Protection class IP66

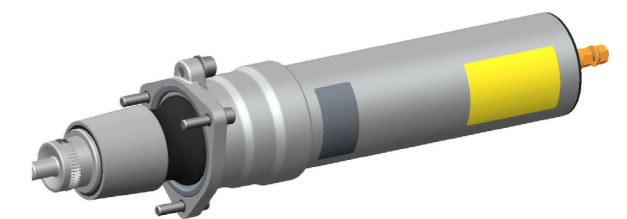

### 3EH4 – connector size 3

Electrical Characteristics

Mechanical Characteristics

Rated voltage	Continuous operating voltage	Arrester type										Designation	Nominal discharge current	Charge transfer rating	Thermal charge transfer rating	Maximum values of the residual voltages at discharge currents of the following impulses					Height	Rated short-circuit current	Housing insulation		Approximate weight of arrester	Dimensioned drawing
		U <sub>r</sub> kV	U <sub>c</sub> kV	30/60 μs 125 A kV	30/60 μs 500 A kV	8/20 μs 1 kA kV	8/20 μs 3 kA kV	8/20 μs 5 kA kV	8/20 μs 10 kA kV	8/20 μs 20 kA kV	H mm					I <sub>sc</sub> kA	Lightning impulse withstand voltage 1.2/50 μs kV	Power-frequency withstand voltage 1 min. kV	kg							
7.5	6.0	3EH4	075	-	2	D	C	1	4	DH	10	0.4	1.1	14.5	15.3	16.3	17.7	18.5	19.9	22.9	432	16	250	100	6.5	D
9.0	7.2	3EH4	090	-	2	D	C	1	4	DH	10	0.4	1.1	17.4	18.4	19.6	21.2	22.2	23.9	27.4	432	16	250	100	6.5	D
12.5	10.0	3EH4	125	-	2	D	C	1	4	DH	10	0.4	1.1	24.2	25.5	27.2	29.5	30.8	33.1	38.1	432	16	250	100	6.5	D
15.0	12.0	3EH4	150	-	2	D	C	1	4	DH	10	0.4	1.1	29.0	30.6	32.6	35.4	37.0	39.8	45.7	432	16	250	100	6.5	D
17.5	14.0	3EH4	175	-	2	D	C	1	4	DH	10	0.4	1.1	33.9	35.7	38.0	41.3	43.1	46.4	53.3	432	16	250	100	6.6	D
19.0	15.2	3EH4	190	-	2	D	C	1	4	DH	10	0.4	1.1	36.8	38.8	41.3	44.8	46.8	50.4	57.9	432	16	250	100	6.6	D
21.5	17.2	3EH4	215	-	2	D	C	1	4	DH	10	0.4	1.1	41.6	43.9	46.7	50.7	53.0	57.0	65.5	432	16	250	100	6.7	D
24.0	19.2	3EH4	240	-	2	D	C	1	4	DH	10	0.4	1.1	46.4	49.0	52.2	56.6	59.1	63.6	73.1	432	16	250	100	6.7	D
30.0	24.0	3EH4	300	-	2	D	C	1	4	DH	10	0.4	1.1	58.0	61.2	65.2	70.8	73.9	79.5	91.4	432	16	250	100	6.8	D
36.0	28.8	3EH4	360	-	2	D	C	1	4	DH	10	0.4	1.1	69.6	73.5	78.2	84.9	88.7	95.4	109.7	432	16	250	100	6.9	D
45.0	36.0	3EH4	450	-	2	D	C	1	4	DH	10	0.4	1.1	87.1	91.8	97.8	106.1	110.9	119.3	137	432	16	250	100	7.0	D
51.0	40.8	3EH4	510	-	2	D	C	1	4	DH	10	0.4	1.1	98.7	104.1	110.8	120.3	125.7	135.2	155	432	16	250	100	7.0	D
52.5	42.0	3EH4	525	-	2	D	C	1	4	DH	10	0.4	1.1	101.6	107.1	114.1	123.8	129.4	139.1	160	432	16	250	100	7.1	D

#### How to order

##### 3EH4, earthed housing

Example 3EH4 215-2LC14	
3EH4	... Plug-in arrester connector size 3
215	... Rated voltage = 21.5 kV
-2	... Connector size 3
L	... Housing size 3, earthed (H=432 mm)
C	... MO resistor type
1	... Indoor application
4	... Protection class IP66

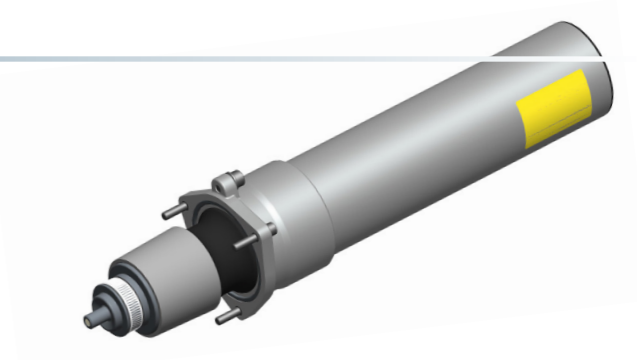

### 3EH4 – connector size 3 - insulated

Electrical Characteristics

Mechanical Characteristics

Rated voltage	Continuous operating voltage	Arresters type											Designation	Nominal discharge current	Charge transfer rating	Thermal charge transfer rating	Maximum values of the residual voltages at discharge currents of the following impulses					Height	Rated short-circuit current	Housing insulation		Approximate weight of arrester	Dimensioned drawing
		U <sub>r</sub> kV	U <sub>c</sub> kV	30/60 μs 125 A kV	30/60 μs 500 A kV	8/20 μs 1 kA kV	8/20 μs 3 kA kV	8/20 μs 5 kA kV	8/20 μs 10 kA kV	8/20 μs 20 kA kV	H mm	I <sub>sc</sub> kA					Lightning impulse withstand voltage 1.2/50 μs kV	Power-frequency withstand voltage 1 min. kV	kg								
7.5	6.0	3EH4	075	-	2	L	C	1	4	DH	10	0.4	1.1	14.5	15.3	16.3	17.7	18.5	19.9	22.9	432	16	250	100	6.5	L	
9.0	7.2	3EH4	090	-	2	L	C	1	4	DH	10	0.4	1.1	17.4	18.4	19.6	21.2	22.2	23.9	27.4	432	16	250	100	6.5	L	
12.5	10.0	3EH4	125	-	2	L	C	1	4	DH	10	0.4	1.1	24.2	25.5	27.2	29.5	30.8	33.1	38.1	432	16	250	100	6.5	L	
15.0	12.0	3EH4	150	-	2	L	C	1	4	DH	10	0.4	1.1	29.0	30.6	32.6	35.4	37.0	39.8	45.7	432	16	250	100	6.5	L	
17.5	14.0	3EH4	175	-	2	L	C	1	4	DH	10	0.4	1.1	33.9	35.7	38.0	41.3	43.1	46.4	53.3	432	16	250	100	6.6	L	
19.0	15.2	3EH4	190	-	2	L	C	1	4	DH	10	0.4	1.1	36.8	38.8	41.3	44.8	46.8	50.4	57.9	432	16	250	100	6.6	L	
21.5	17.2	3EH4	215	-	2	L	C	1	4	DH	10	0.4	1.1	41.6	43.9	46.7	50.7	53.0	57.0	65.5	432	16	250	100	6.7	L	
24.0	19.2	3EH4	240	-	2	L	C	1	4	DH	10	0.4	1.1	46.4	49.0	52.2	56.6	59.1	63.6	73.1	432	16	250	100	6.7	L	
30.0	24.0	3EH4	300	-	2	L	C	1	4	DH	10	0.4	1.1	58.0	61.2	65.2	70.8	73.9	79.5	91.4	432	16	250	100	6.8	L	
36.0	28.8	3EH4	360	-	2	L	C	1	4	DH	10	0.4	1.1	69.6	73.5	78.2	84.9	88.7	95.4	109.7	432	16	250	100	6.9	L	
45.0	36.0	3EH4	450	-	2	L	C	1	4	DH	10	0.4	1.1	87.1	91.8	97.8	106.1	110.9	119.3	137	432	16	250	100	7.0	L	
51.0	40.8	3EH4	510	-	2	L	C	1	4	DH	10	0.4	1.1	98.7	104.1	110.8	120.3	125.7	135.2	155	432	16	250	100	7.0	L	
52.5	42.0	3EH4	525	-	2	L	C	1	4	DH	10	0.4	1.1	101.6	107.1	114.1	123.8	129.4	139.1	160	432	16	250	100	7.1	L	

#### How to order

##### 3EH4, insulated housing

###### Example 3EH4 215-2LC14

- 3EH4 ... Plug-in arrester connector size 3
- 215 ... Rated voltage = 21.5 kV
- 2 ... Connector size 3
- L ... Housing size 3, insulated (H=432 mm)
- C ... MO resistor type
- 1 ... Indoor application
- 4 ... Protection class IP66

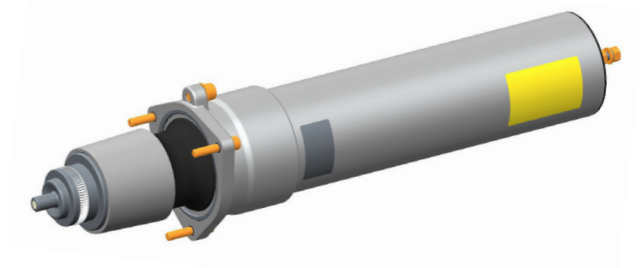

# Dimensioned drawings

## Dimensions of 3EH4 (335 mm)

Dimensioned drawing B

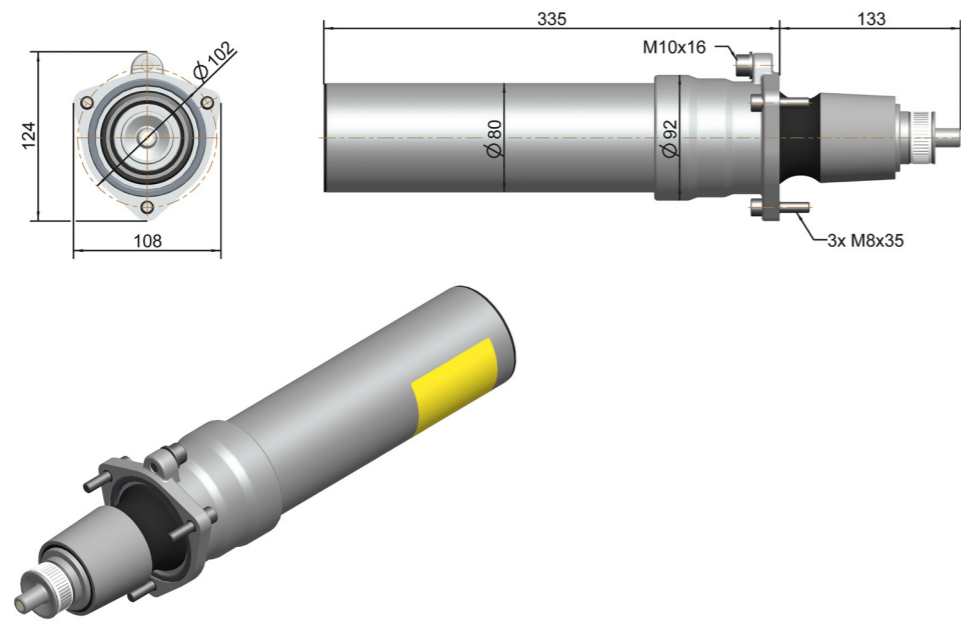

## Dimensions of 3EH4 (466 mm)

Dimensioned drawing C

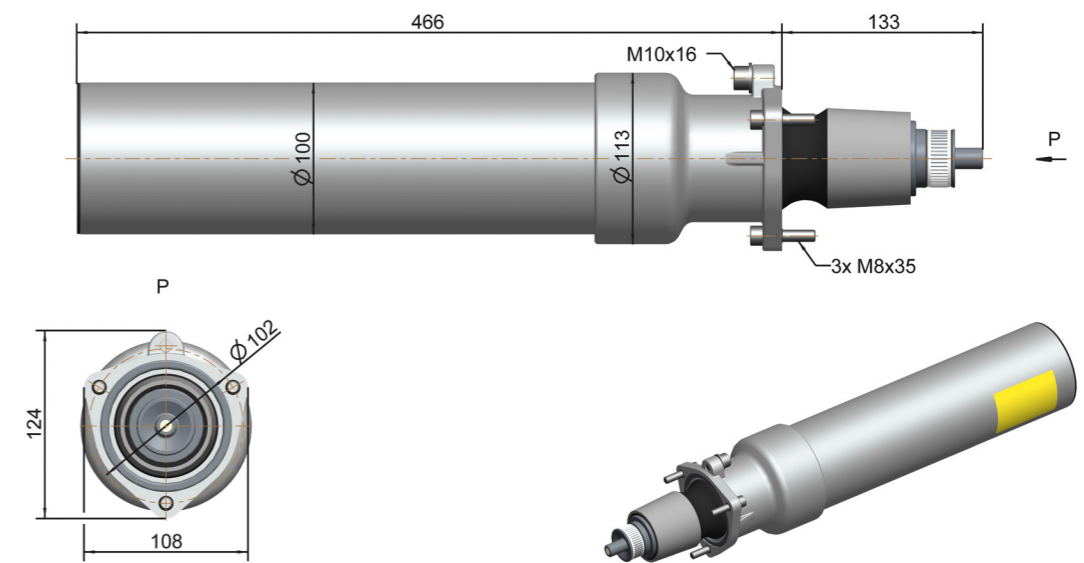

## Dimensions of 3EH4 insulated (335 mm)

Dimensioned drawing J

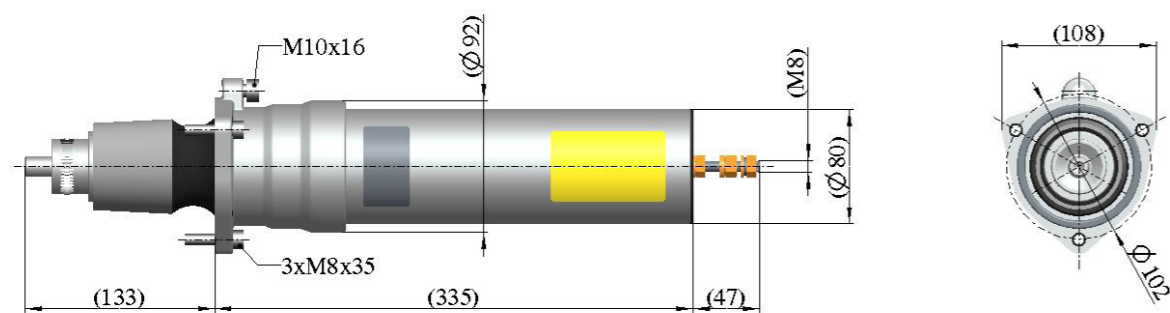

## Dimensions of 3EH4 insulated (466 mm)

Dimensioned drawing K

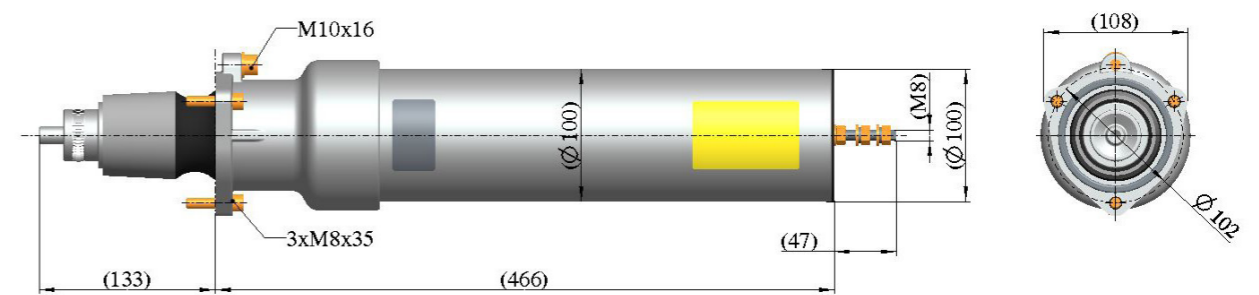

# Dimensioned drawings

## Dimensions of 3EH4 (432 mm)

Dimensioned drawing D

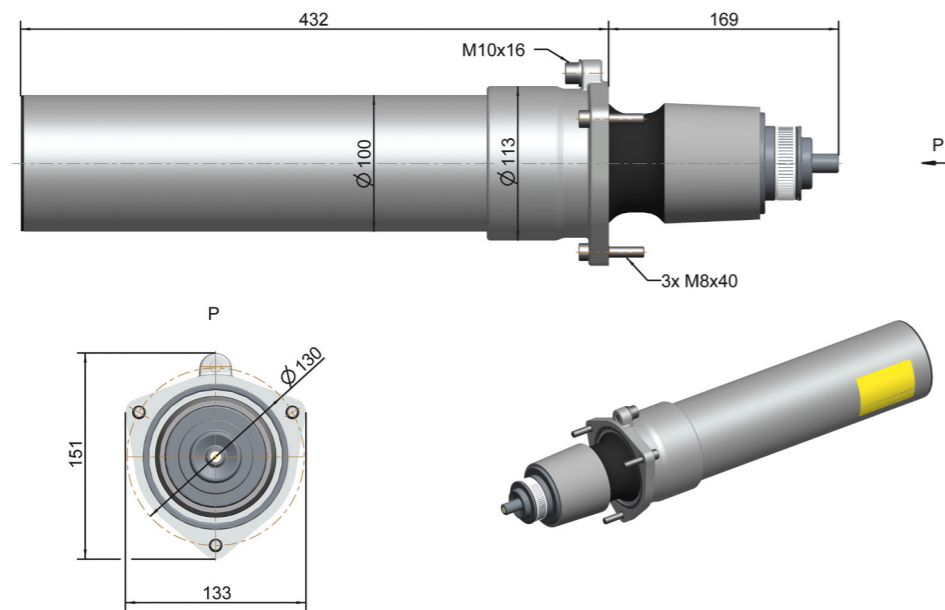

## Packing dimension 3EH4

Housing	Length mm	Width mm	Height mm
Housing B	150	150	504
Housing C	200	200	632
Housing D	200	200	632

## Packing dimension 3EH4 insulated

Housing	Length mm	Width mm	Height mm
Housing J	150	150	554
Housing K	200	200	682
Housing L	200	200	682

## Dimensions of 3EH4 insulated (432 mm)

Dimensioned drawing L

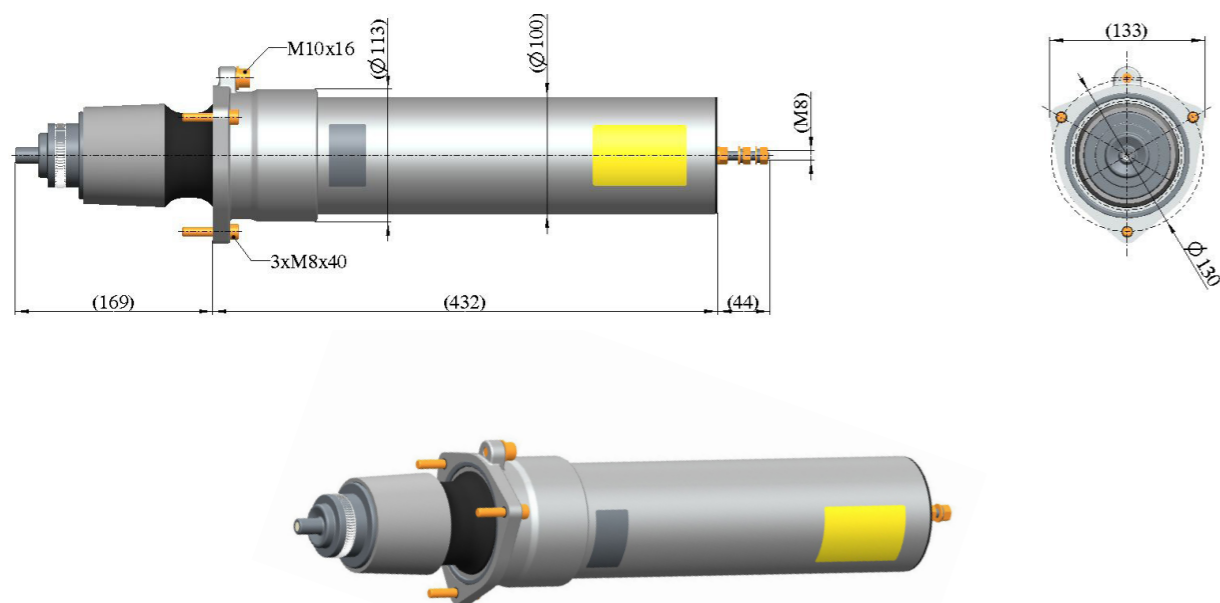

# 3EJ Surge arresters with high energy discharge capabilities

Siemens Energy cage design 3EJ high energy discharge surge arresters offer superior protection against overvoltages in medium-voltage systems.

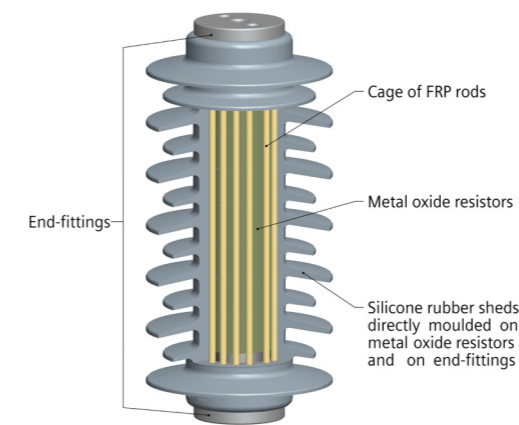

Siemens Energy 3EJ cage design surge arresters are ideally suited for the reliable protection of:

- Generators
- Motors
- Arc furnaces
- Arc furnace transformers
- Dry type transformers
- Airfield-lighting systems
- Cable sheath
- Capacitors and capacitor banks
- Converters for drives

The metal oxide resistors (MOV) are enclosed by a cage made of fiber-reinforced plastic (FRP) rods, providing a rigid, reinforced structure ensuring high mechanical strength.

Reliability is guaranteed by the direct molding of the silicone rubber onto the MOVs and the FRP rods. This ensures the total embedding of all components free of inclusions and gaps, thus providing an excellent sealing system, which avoids partial discharges or moisture ingress.

In the extremely rare event of the MOVs being overloaded, arcing cannot result in a buildup of critical internal pressure, since the MOVs are not enclosed in a sealed mechanical shell. The arc can escape directly through the soft silicone housing, leaving the mechanical support structure of the enclosure unharmed. The ejection of internal parts that could damage other equipment nearby is prevented almost completely. Siemens Energy' innovative cage design ensures outstanding performance in safety issues.

Silicone rubber is highly hydrophobic and maintains its ability to repel water and any deposits of pollution throughout its entire service life. This results in high tracking and erosion resistance. The silicone rubber housing is self-extinguishing and flame-retardant. These advantages provide maintenance-free and reliable service life for 3EJ surge arresters.

Siemens Energy offers five product lines for the application with high energy discharge, which differentiate in the protection level:

- 3EJ2 – for rated voltages up to 54 kV, medium energy discharge capability.
- 3EJ3 – for rated voltages up to 54 kV, high energy discharge capability.
- 3EJ4 – for rated voltages up to 54 kV, very high energy discharge capability.
- 3EJ0 – for rated voltages up to 15 kV, very low protection levels for protection against switching over voltages.
- 3EJ9 – for rated voltages up to 12 kV, very low protection levels for protection against switching over voltages.

The proven 3EJ4 is also available in a version for indoor application, offering the same benefits as the version for outdoor application.

The 3EJ0 and 3EJ9 surge arresters have been optimized for the protection against overvoltages caused by switching in combination with very low protection levels. The 3EJ0 surge arresters are normally used in cable systems up to 15 kV. For station service systems of power stations and extensive cable systems the 3EJ9 surge arresters are used having a higher energy absorption capability and improved protection level.

### 3EJ2 specifications according to IEC 60099-4 standard

#### Electrical Characteristics

Rated voltage $U_r$ kV	Continuous operating voltage $U_c$ kV	Arrester type	Designation	Nominal discharge current $I_n$ kA	Charge transfer rating $Q_n$ C	Thermal energy rating $W_{th}$ kJ/kV <sub>r</sub>	Maximum values of the residual voltages at discharge currents of the following impulses							
							30/60μs 125 A kV	30/60μs 500 A kV	8/20μs 1 kA kV	8/20μs 3 kA kV	8/20μs 5 kA kV	8/20μs 10 kA kV	8/20μs 20 kA kV	
1.5	1.2	3EJ2 001 - 5 C B 3 1 - 4	SM	10	2.0	7.0	2.7	2.8	3.0	3.2	3.3	3.5	3.9	
3.0	2.4	3EJ2 003 - 0 C B 3 1 - 4	SM	10	2.0	7.0	5.4	5.6	5.9	6.3	6.6	7.1	7.8	
4.5	3.6	3EJ2 004 - 5 C B 3 1 - 4	SM	10	2.0	7.0	8.0	8.5	8.9	9.5	9.9	10.6	11.7	
6.0	4.8	3EJ2 006 - 0 C B 3 1 - 4	SM	10	2.0	7.0	10.7	11.3	11.8	12.7	13.3	14.1	15.7	
7.5	6.0	3EJ2 007 - 5 C C 3 1 - 4	SM	10	2.0	7.0	13.4	14.1	14.8	15.9	16.6	17.6	19.6	
9.0	7.2	3EJ2 009 - 0 C C 3 1 - 4	SM	10	2.0	7.0	16.1	16.9	17.8	19.0	19.9	21.2	23.5	
10.5	8.4	3EJ2 010 - 5 C C 3 1 - 4	SM	10	2.0	7.0	18.8	19.7	20.7	22.2	23.2	24.7	27.4	
12	9.6	3EJ2 012 - 0 C C 3 1 - 4	SM	10	2.0	7.0	21.4	22.6	23.7	25.4	26.5	28.2	31.3	
15	12.0	3EJ2 015 - 0 C D 3 1 - 4	SM	10	2.0	7.0	26.8	28.2	29.6	31.7	33.1	35.3	39.1	
18	14.4	3EJ2 018 - 0 C D 3 1 - 4	SM	10	2.0	7.0	32.1	33.8	35.5	38.1	39.8	42.3	47.0	
21	16.8	3EJ2 021 - 0 C D 3 1 - 4	SM	10	2.0	7.0	37.5	39.5	41.5	44.4	46.4	49.4	54.8	
24	19.2	3EJ2 024 - 0 C E 3 1 - 4	SM	10	2.0	7.0	42.9	45.1	47.4	50.8	53.0	56.4	62.6	
27	21.6	3EJ2 027 - 0 C E 3 1 - 4	SM	10	2.0	7.0	48.2	50.8	53.3	57.1	59.6	63.5	70.4	
30	24.0	3EJ2 030 - 0 C F 3 1 - 4	SM	10	2.0	7.0	53.6	56.4	59.2	63.5	66.3	70.5	78.3	
36	28.8	3EJ2 036 - 0 C G 3 1 - 4	SM	10	2.0	7.0	64.3	67.7	71.1	76.1	79.5	84.6	93.9	
42	33.6	3EJ2 042 - 0 C G 3 1 - 4	SM	10	2.0	7.0	75.0	79.0	82.9	88.8	92.8	98.7	110	
45	36.0	3EJ2 045 - 0 C H 3 1 - 4	SM	10	2.0	7.0	80.4	84.6	88.8	95.2	99.4	106	117	
48	38.4	3EJ2 048 - 0 C H 3 1 - 4	SM	10	2.0	7.0	85.7	90.2	94.8	102	106	113	125	
51	40.8	3EJ2 051 - 0 C J 3 1 - 4	SM	10	2.0	7.0	91.1	95.9	100.7	108	113	120	133	
54	43.2	3EJ2 054 - 0 C J 3 1 - 4	SM	10	2.0	7.0	96.4	101.5	106.6	114	119	127	141	

#### Mechanical Characteristics

Height [H]	Creepage distance	Rated short-circuit current	Lightning impulse withstand voltage	Power frequency withstand voltage, wet	Specified short-term load SSL	Specified long-term load SLL	Approximate weight of arrester without accessories	Flashover distance
mm	mm	$I_s$ kA	1.2/50μs kV	1 min. kV	N	N	kg	mm
166	430	50	100	45	6020	4210	3.0	173
166	430	50	100	45	6020	4210	3.2	173
166	430	50	100	45	6020	4210	3.3	173
166	430	50	100	45	6020	4210	3.4	173
211	590	50	125	60	4730	3310	4.0	218
211	590	50	125	60	4730	3310	4.1	218
211	590	50	125	60	4730	3310	4.3	218
211	590	50	125	60	4730	3310	4.4	218
256	750	50	150	70	3900	2730	5.2	262
256	750	50	150	70	3900	2730	5.5	262
256	750	50	150	70	3900	2730	5.7	262
301	920	50	175	80	3320	2320	6.4	306
301	920	50	175	80	3320	2320	6.8	306
346	1090	50	200	95	2890	2020	7.4	350
391	1250	50	225	105	2550	1790	8.3	394
391	1250	50	225	105	2550	1790	8.9	394
436	1420	50	250	120	2290	1600	9.5	438
436	1420	50	250	120	2290	1600	9.9	438
481	1580	50	275	130	2070	1450	10.5	482
481	1580	50	275	130	2070	1450	11.0	482

#### How to order

##### 3EJ2 IEC

Example 3EJ2 010-5CC31-4	
3EJ2	... with medium energy discharge capability
010-5	... Rated voltage = 10.5 kV
C	... IEC
C	... Housing type (H=211 mm)
3	... Energy class $W_{th} = 7$ kJ/kV <sub>r</sub>
1	... 1 unit
-4	... Alternating sheds

#### Dimensions 3EJ2 IEC

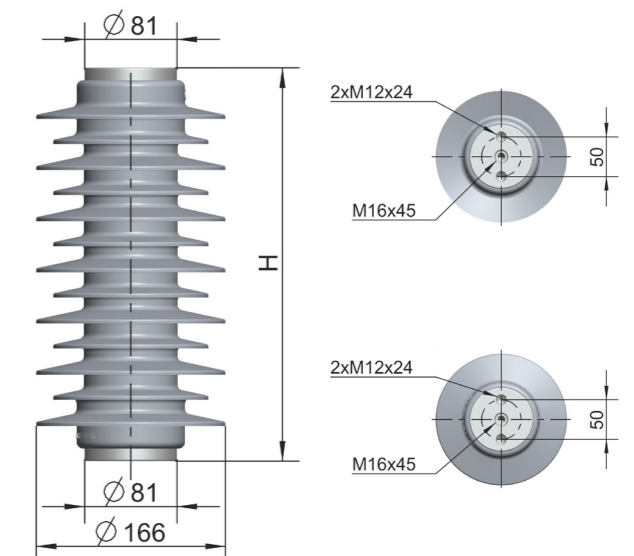

### 3EJ2 specifications according to IEEE C62.11 standard

**Electrical Characteristics**

Rated voltage $U_r$ kV	Continuous operating voltage $U_c$ kV	Arrester type	Energy class	Lightning impulse classifying current $I_{tr}$ kA	Switching surge energy rating kJ/kV <sub>MCOV</sub>	Single impulse withstand rating C	Protective Level maximum discharge voltage							
							45/90µs 125 A kV cr	45/90µs 500 A kV cr	8/20µs 1.5 kA kV cr	8/20µs 3 kA kV cr	8/20µs 5 kA kV cr	8/20µs 10 kA kV cr	8/20µs 20 kA kV cr	
3.0	2.55	3EJ2 003 - 0 A B 3 1 - 4	E	10	9.0	2.0	5.5	5.8	6.2	6.5	6.8	7.2	8.0	
6.0	5.10	3EJ2 006 - 0 A B 3 1 - 4	E	10	9.0	2.0	10.9	11.5	12.4	13.0	13.5	14.4	16.0	
9.0	7.65	3EJ2 009 - 0 A C 3 1 - 4	E	10	9.0	2.0	16.4	17.3	18.6	19.4	20.3	21.6	24.0	
10	8.40	3EJ2 010 - 0 A C 3 1 - 4	E	10	9.0	2.0	18.2	19.2	20.6	21.6	22.6	24.0	26.6	
12	10.2	3EJ2 012 - 0 A C 3 1 - 4	E	10	9.0	2.0	21.9	23.0	24.8	25.9	27.1	28.8	32.0	
15	12.7	3EJ2 015 - 0 A D 3 1 - 4	E	10	9.0	2.0	27.4	28.8	31.0	32.4	33.8	36.0	40.0	
18	15.3	3EJ2 018 - 0 A D 3 1 - 4	E	10	9.0	2.0	32.8	34.6	37.2	38.9	40.6	43.2	48.0	
21	17.0	3EJ2 021 - 0 A D 3 1 - 4	E	10	9.0	2.0	38.3	40.3	43.3	45.4	47.4	50.4	55.9	
24	19.5	3EJ2 024 - 0 A E 3 1 - 4	E	10	9.0	2.0	43.8	46.1	49.5	51.8	54.1	57.6	63.9	
27	22.0	3EJ2 027 - 0 A E 3 1 - 4	E	10	9.0	2.0	49.2	51.8	55.7	58.3	60.9	64.8	71.9	
30	24.4	3EJ2 030 - 0 A F 3 1 - 4	E	10	9.0	2.0	54.7	57.6	61.9	64.8	67.7	72.0	79.9	
36	29.0	3EJ2 036 - 0 A G 3 1 - 4	E	10	9.0	2.0	65.7	69.1	74.3	77.8	81.2	86.4	95.9	

**Mechanical Characteristics**

Height [H] inch	Leakage distance inch	Rated short-circuit current $I_s$ kA	Recommended minimum clearances		Maximum design cantilever load MDCL lbf	Specified short-term load SSL lbf	Approximate weight of arrester without accessories lbs
			To ground (ph-gnd) inch	Between phases (ph-ph) inch			
6.5	16.9	50	5	8	948	1354	11.0
6.5	16.9	50	5	8	948	1354	11.7
8.3	23.2	50	6	9	746	1065	13.4
8.3	23.2	50	6	9	746	1065	13.7
8.3	23.2	50	6	9	746	1065	14.3
10.1	29.5	50	8	12	615	878	16.1
10.1	29.5	50	8	12	615	878	16.8
10.1	29.5	50	8	12	615	878	17.2
11.9	36.2	50	10	15	523	747	19.0
11.9	36.2	50	10	15	523	747	19.8
13.6	42.9	50	10	15	455	650	21.6
15.4	49.2	50	14	19	402	575	24.0

#### How to order

**3EJ2 IEEE**

Example 3EJ2 010-0AC31-4	
3EJ2	... with medium energy discharge capability
010-0	... Rated voltage = 10.0 kV
A	... IEEE
C	... Housing type (H=211 mm)
3	... Switching surge energy rating 9 kJ/kV <sub>MCOV</sub>
1	... 1 unit
-4	... Alternating sheds

#### Dimensions 3EJ2 IEEE

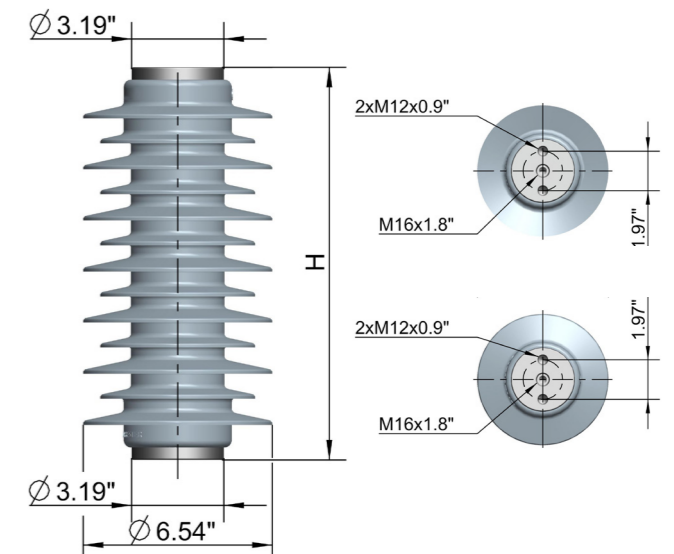

### 3EJ3 specifications according to IEC 60099-4 standard

Electrical Characteristics

Rated voltage $U_r$ kV	Continu-ous operating voltage $U_c$ kV	Arrester type	Desig-nation	Nominal dis-charge current $I_n$ kA	Charge transfer rating $Q_{15}$ C	Thermal energy rating $W_{th}$ kJ/kV <sub>r</sub>	Maximum values of the residual voltages at discharge currents of the following impulses							
							30/60µs 125 A kV	30/60µs 500 A kV	8/20µs 1 kA kV	8/20µs 3 kA kV	8/20µs 5 kA kV	8/20µs 10 kA kV	8/20µs 20 kA kV	
1.4	1.1	3EJ3 001 - 4 C B 5 1 - 4	SH	20	3.6	14.0	2.5	2.6	2.7	2.9	3.0	3.2	3.4	
1.8	1.4	3EJ3 001 - 8 C B 5 1 - 4	SH	20	3.6	14.0	3.2	3.4	3.5	3.7	3.8	4.1	4.4	
2.0	1.6	3EJ3 002 - 0 C B 5 1 - 4	SH	20	3.6	14.0	3.6	3.7	3.9	4.1	4.3	4.5	4.9	
2.5	2.0	3EJ3 002 - 5 C B 5 1 - 4	SH	20	3.6	14.0	4.4	4.7	4.8	5.1	5.3	5.6	6.1	
3.0	2.4	3EJ3 003 - 0 C B 4 1 - 4	SH	20	2.8	10.0	5.3	5.6	5.8	6.1	6.4	6.8	7.4	
3.0	2.4	3EJ3 003 - 0 C B 5 1 - 4	SH	20	3.6	14.0	5.3	5.6	5.8	6.1	6.4	6.8	7.4	
3.4	2.7	3EJ3 003 - 4 C B 5 1 - 4	SH	20	3.6	14.0	6.0	6.4	6.6	7.0	7.2	7.7	8.3	
4.0	3.2	3EJ3 004 - 0 C B 5 1 - 4	SH	20	3.6	14.0	7.1	7.5	7.7	8.2	8.5	9.0	9.8	
4.5	3.6	3EJ3 004 - 5 C B 5 1 - 4	SH	20	3.6	14.0	8.0	8.4	8.7	9.2	9.6	10.1	11.0	
4.8	3.8	3EJ3 004 - 8 C B 5 1 - 4	SH	20	3.6	14.0	8.5	9.0	9.3	9.8	10.2	10.8	11.8	
5.2	4.2	3EJ3 005 - 2 C B 5 1 - 4	SH	20	3.6	14.0	9.2	9.7	10.1	10.6	11.1	11.7	12.8	
6.0	4.8	3EJ3 006 - 0 C B 4 1 - 4	SH	20	2.8	10.0	10.7	11.2	11.6	12.3	12.8	13.5	14.7	
6.0	4.8	3EJ3 006 - 0 C C 5 1 - 4	SH	20	3.6	14.0	10.7	11.2	11.6	12.3	12.8	13.5	14.7	
6.3	5.0	3EJ3 006 - 3 C C 5 1 - 4	SH	20	3.6	14.0	11.2	11.8	12.2	12.9	13.4	14.2	15.5	
7.6	6.1	3EJ3 007 - 6 C C 5 1 - 4	SH	20	3.6	14.0	13.5	14.2	14.7	15.6	16.2	17.1	18.6	
8.6	6.9	3EJ3 008 - 6 C C 5 1 - 4	SH	20	3.6	14.0	15.3	16.1	16.6	17.6	18.3	19.4	21.1	
9.0	7.2	3EJ3 009 - 0 C C 4 1 - 4	SH	20	2.8	10.0	16.0	16.8	17.4	18.4	19.1	20.3	22.1	
9.0	7.2	3EJ3 009 - 0 C C 5 1 - 4	SH	20	3.6	14.0	16.0	16.8	17.4	18.4	19.1	20.3	22.1	
10.5	8.4	3EJ3 010 - 5 C C 4 1 - 4	SH	20	2.8	10.0	18.7	19.6	20.3	21.5	22.3	23.6	25.8	
10.5	8.4	3EJ3 010 - 5 C C 5 1 - 4	SH	20	3.6	14.0	18.7	19.6	20.3	21.5	22.3	23.6	25.8	
12	9.6	3EJ3 012 - 0 C C 4 1 - 4	SH	20	2.8	10.0	21.3	22.4	23.2	24.6	25.5	27.0	29.4	
12	9.6	3EJ3 012 - 0 C D 5 1 - 4	SH	20	3.6	14.0	21.3	22.4	23.2	24.6	25.5	27.0	29.4	
12.4	9.9	3EJ3 012 - 4 C D 5 1 - 4	SH	20	3.6	14.0	22.0	23.2	24.0	25.4	26.4	27.9	30.4	
15	12.0	3EJ3 015 - 0 C D 4 1 - 4	SH	20	2.8	10.0	26.7	28.0	29.0	30.7	31.9	33.8	36.8	
15	12.0	3EJ3 015 - 0 C D 5 1 - 4	SH	20	3.6	14.0	26.7	28.0	29.0	30.7	31.9	33.8	36.8	
18	14.4	3EJ3 018 - 0 C D 4 1 - 4	SH	20	2.8	10.0	32.0	33.6	34.8	36.9	38.3	40.5	44.2	
18	14.4	3EJ3 018 - 0 C E 5 1 - 4	SH	20	3.6	14.0	32.0	33.6	34.8	36.9	38.3	40.5	44.2	
21	16.8	3EJ3 021 - 0 C E 4 1 - 4	SH	20	2.8	10.0	37.3	39.2	40.6	43.0	44.6	47.3	51.5	
21	16.8	3EJ3 021 - 0 C E 5 1 - 4	SH	20	3.6	14.0	37.3	39.2	40.6	43.0	44.6	47.3	51.5	
24	19.2	3EJ3 024 - 0 C E 4 1 - 4	SH	20	2.8	10.0	42.7	44.8	46.4	49.2	51.0	54.0	58.9	
24	19.2	3EJ3 024 - 0 C F 5 1 - 4	SH	20	3.6	14.0	42.7	44.8	46.4	49.2	51.0	54.0	58.9	
27	21.6	3EJ3 027 - 0 C F 4 1 - 4	SH	20	2.8	10.0	48.0	50.4	52.2	55.3	57.4	60.8	66.2	
27	21.6	3EJ3 027 - 0 C F 5 1 - 4	SH	20	3.6	14.0	48.0	50.4	52.2	55.3	57.4	60.8	66.2	
30	24.0	3EJ3 030 - 0 C F 4 1 - 4	SH	20	2.8	10.0	53.3	56.0	58.1	61.4	63.8	67.5	73.6	
30	24.0	3EJ3 030 - 0 C G 5 1 - 4	SH	20	3.6	14.0	53.3	56.0	58.1	61.4	63.8	67.5	73.6	
36	28.8	3EJ3 036 - 0 C G 4 1 - 4	SH	20	2.8	10.0	64.0	67.2	69.7	73.7	76.5	81.0	88.3	
36	28.8	3EJ3 036 - 0 C H 5 1 - 4	SH	20	3.6	14.0	64.0	67.2	69.7	73.7	76.5	81.0	88.3	
42	33.6	3EJ3 042 - 0 C H 4 1 - 4	SH	20	2.8	10.0	74.7	78.5	81.3	86.0	89.3	94.5	103	
42	33.6	3EJ3 042 - 0 C J 5 1 - 4	SH	20	3.6	14.0	74.7	78.5	81.3	86.0	89.3	94.5	103	
45	36.0	3EJ3 045 - 0 C J 4 1 - 4	SH	20	2.8	10.0	79.8	83.9	86.9	91.9	95.4	101	110	
45	36.0	3EJ3 045 - 0 C J 5 1 - 4	SH	20	3.6	14.0	79.8	83.9	86.9	91.9	95.4	101	110	
48	38.4	3EJ3 048 - 0 C J 4 1 - 4	SH	20	2.8	10.0	85.3	89.7	92.9	98.3	102	108	118	
48	38.4	3EJ3 048 - 0 C K 5 1 - 4	SH	20	3.6	14.0	85.3	89.7	92.9	98.3	102	108	118	
51	40.8	3EJ3 051 - 0 C K 4 1 - 4	SH	20	2.8	10.0	90.9	95.5	98.9	105	109	115	125	
51	40.8	3EJ3 051 - 0 C K 5 1 - 4	SH	20	3.6	14.0	90.9	95.5	98.9	105	109	115	125	
54	43.2	3EJ3 054 - 0 C K 4 1 - 4	SH	20	2.8	10.0	96.4	101	105	111	115	122	133	
54	43.2	3EJ3 054 - 0 C L 5 1 - 4	SH	20	3.6	14.0	96.4	101	105	111	115	122	133	

Mechanical Characteristics

Height [H] mm	Creepage distance mm	Rated short-circuit current $I_s$ kA	Lightning impulse withstand voltage 1.2/50µs kV	Power frequency withstand voltage, wet 1 min. kV	Specified short-term load SSL N	Specified long-term load SLL N	Approximate weight of arrester without accessories kg	Flashover distance mm
172	390	65	105	50	8720	6100	5.0	182
172	390	65	105	50	8720	6100	5.1	182
172	390	65	105	50	8720	6100	5.1	182
172	390	65	105	50	8720	6100	5.2	182
172	390	65	105	50	8720	6100	5.2	182
172	390	65	105	50	8720	6100	5.3	182
172	390	65	105	50	8720	6100	5.4	182
172	390	65	105	50	8720	6100	5.5	182
172	390	65	105	50	8720	6100	5.6	182
172	390	65	105	50	8720	6100	5.7	182
172	390	65	105	50	8720	6100	5.7	182
208	550	65	125	60	7210	5040	6.3	218
208	550	65	125	60	7210	5040	6.4	218
208	550	65	125	60	7210	5040	6.6	218
208	550	65	125	60	7210	5040	6.7	218
208	550	65	125	60	7210	5040	6.7	218
208	550	65	125	60	7210	5040	7.0	218
208	550	65	125	60	7210	5040	7.0	218
208	550	65	125	60	7210	5040	7.2	218
244	700	65	145	70	6140	4300	7.8	253
244	700	65	145	70	6140	4300	7.9	253
244	700	65	145	70	6140	4300	8.2	253
244	700	65	145	70	6140	4300	8.3	253
244	700	65	145	70	6140	4300	8.6	253
281	860	65	165	75	5330	3730	9.4	288
281	860	65	165	75	5330	3730	9.7	288
281	860	65	165	75	5330	3730	9.9	288
281	860	65	165	75	5330	3730	10.1	288
317	1020	65	185	85	4730	3310	10.9	323
317	1020	65	185	85	4730	3310	11.1	323
317	1020	65	185	85	4730	3310	11.6	323
317	1020	65	185	85	4730	3310	11.6	323
353	1170	65	210	95	4240	2970	12.4	360
353	1170	65	210	95	4240	2970	13.1	360
389	1330	65	230	105	3850	2690	14.1	395
389	1330	65	230	105	3850	2690	14.5	395
425	1480	65	250	115	3520	2470	15.6	430
425	1480	65	250	115	3520	2470	15.6	430
425	1480	65	250	115	3520	2470	16.0	430
425	1480	65	250	115	3520	2470	16.0	430
462	1640	65	270	125	3240	2270	17.0	466
462	1640	65	270	125	3240	2270	17.0	466
462	1640	65	270	125	3240	2270	17.5	466
462	1640	65	270	125	3240	2270	17.5	466
498	1800	65	290	135	3010	2100	18.5	501

### 3EJ3 specifications according to IEEE C62.11 standard

#### Electrical Characteristics

Duty cycle voltage $U_p$ kV	MCOV $U_c$ kV	Arrester order number	Energy class	Lightning impulse classifying current $I_n$ kA	Switching surge energy rating kJ/kV <sub>MCOV</sub>	Single impulse withstand rating C	Protective Level Maximum discharge voltage							
							45/90µs 125 A kV cr	45/90µs 500 A kV cr	8/20µs 1.5 kA kV cr	8/20µs 3 kA kV cr	8/20µs 5 kA kV cr	8/20µs 10 kA kV cr	8/20µs 20 kA kV cr	
3.0	2.55	3EJ3 003 - 0 A B 4 1 - 4	G	15	13.0	2.8	5.3	5.6	5.9	6.1	6.4	6.8	7.4	
3.0	2.55	3EJ3 003 - 0 A B 5 1 - 4	J	20	18.0	3.6	5.3	5.6	5.9	6.1	6.4	6.8	7.4	
6.0	5.10	3EJ3 006 - 0 A B 4 1 - 4	G	15	13.0	2.8	10.7	11.2	11.9	12.3	12.8	13.5	14.7	
6.0	5.10	3EJ3 006 - 0 A C 5 1 - 4	J	20	18.0	3.6	10.7	11.2	11.9	12.3	12.8	13.5	14.7	
9.0	7.65	3EJ3 009 - 0 A C 4 1 - 4	G	15	13.0	2.8	16.0	16.8	17.8	18.4	19.1	20.3	22.1	
9.0	7.65	3EJ3 009 - 0 A C 5 1 - 4	J	20	18.0	3.6	16.0	16.8	17.8	18.4	19.1	20.3	22.1	
10	8.40	3EJ3 010 - 0 A C 4 1 - 4	G	15	13.0	2.8	17.8	18.7	19.8	20.5	21.3	22.5	24.5	
10	8.40	3EJ3 010 - 0 A C 5 1 - 4	J	20	18.0	3.6	17.8	18.7	19.8	20.5	21.3	22.5	24.5	
12	10.2	3EJ3 012 - 0 A C 4 1 - 4	G	15	13.0	2.8	21.3	22.4	23.8	24.6	25.5	27.0	29.4	
12	10.2	3EJ3 012 - 0 A D 5 1 - 4	J	20	18.0	3.6	21.3	22.4	23.8	24.6	25.5	27.0	29.4	
15	12.7	3EJ3 015 - 0 A D 4 1 - 4	G	15	13.0	2.8	26.7	28.0	29.7	30.7	31.9	33.8	36.8	
15	12.7	3EJ3 015 - 0 A D 5 1 - 4	J	20	18.0	3.6	26.7	28.0	29.7	30.7	31.9	33.8	36.8	
18	15.3	3EJ3 018 - 0 A D 4 1 - 4	G	15	13.0	2.8	32.0	33.6	35.6	36.9	38.3	40.5	44.2	
18	15.3	3EJ3 018 - 0 A E 5 1 - 4	J	20	18.0	3.6	32.0	33.6	35.6	36.9	38.3	40.5	44.2	
21	17.0	3EJ3 021 - 0 A E 4 1 - 4	G	15	13.0	2.8	37.3	39.2	41.6	43.0	44.6	47.3	51.5	
21	17.0	3EJ3 021 - 0 A E 5 1 - 4	J	20	18.0	3.6	37.3	39.2	41.6	43.0	44.6	47.3	51.5	
24	19.5	3EJ3 024 - 0 A E 4 1 - 4	G	15	13.0	2.8	42.7	44.8	47.5	49.2	51.0	54.0	58.9	
24	19.5	3EJ3 024 - 0 A F 5 1 - 4	J	20	18.0	3.6	42.7	44.8	47.5	49.2	51.0	54.0	58.9	
27	22.0	3EJ3 027 - 0 A F 4 1 - 4	G	15	13.0	2.8	48.0	50.4	53.5	55.3	57.4	60.8	66.2	
27	22.0	3EJ3 027 - 0 A F 5 1 - 4	J	20	18.0	3.6	48.0	50.4	53.5	55.3	57.4	60.8	66.2	
30	24.4	3EJ3 030 - 0 A F 4 1 - 4	G	15	13.0	2.8	53.3	56.0	59.4	61.4	63.8	67.5	73.6	
30	24.4	3EJ3 030 - 0 A G 5 1 - 4	J	20	18.0	3.6	53.3	56.0	59.4	61.4	63.8	67.5	73.6	
36	29.0	3EJ3 036 - 0 A G 4 1 - 4	G	15	13.0	2.8	64.0	67.2	71.3	73.7	76.5	81.0	88.3	
36	29.0	3EJ3 036 - 0 A H 5 1 - 4	J	20	18.0	3.6	64.0	67.2	71.3	73.7	76.5	81.0	88.3	

#### Mechanical Characteristics

Height [H] inch	Leakage distance inch	Rated short-circuit current $I_s$ kA	Recommended minimum clearances		Maximum design cantilever load MDCL lbf	Specified short-term load SSL lbf	Approximate weight of arrester without accessories lbs
			To ground (ph-gnd) inch	Between phases (ph-ph) inch			
6.8	15.4	65	5	9	1372	1961	11.5
6.8	15.4	65	5	9	1372	1961	11.5
6.8	15.4	65	5	9	1372	1961	12.6
8.2	21.7	65	5	9	1135	1621	13.9
8.2	21.7	65	6	10	1135	1621	14.8
8.2	21.7	65	6	10	1135	1621	15.0
8.2	21.7	65	6	10	1135	1621	15.4
8.2	21.7	65	6	10	1135	1621	15.4
8.2	21.7	65	6	10	1135	1621	15.9
9.6	27.6	65	6	10	967	1382	17.2
9.6	27.6	65	9	13	967	1382	18.1
9.6	27.6	65	9	13	967	1382	18.3
9.6	27.6	65	9	13	967	1382	19.0
11.1	33.9	65	9	13	840	1200	20.7
11.1	33.9	65	9	13	840	1200	21.4
11.1	33.9	65	9	13	840	1200	21.8
11.1	33.9	65	10	15	840	1200	22.3
12.5	40.2	65	10	15	745	1064	24.0
12.5	40.2	65	10	15	745	1064	24.5
12.5	40.2	65	10	15	745	1064	25.6
12.5	40.2	65	10	15	745	1064	25.6
13.9	46.1	65	10	15	669	955	27.3
13.9	46.1	65	14	19	669	955	28.9
15.3	52.4	65	14	19	607	867	31.1

#### How to order

##### 3EJ3 IEC

Example 3EJ3 010-5CC51-4	
3EJ3	... 3EJ3 with high energy discharge capability
010-5	... Rated voltage = 10.5 kV
A	... IEC
C	... Housing type (H=208 mm)
5	... Energy class $W_{th} = 14$ kJ/kV <sub>c</sub>
1	... 1 unit
-4	... Alternating sheds

#### Dimensions 3EJ3 IEC

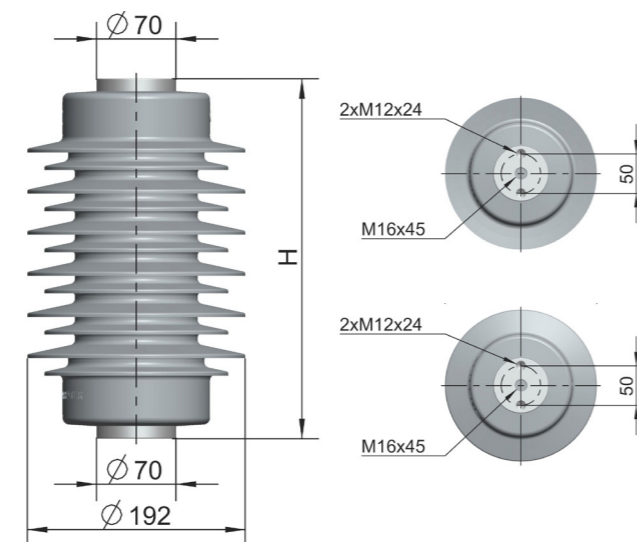

#### How to order

##### 3EJ3 IEEE

Example 3EJ3 010-0AC41-4	
3EJ2	... with high energy discharge capability
010-0	... Rated voltage = 10.0 kV
A	... IEEE
C	... Housing type (H=208 mm)
3	... Switching surge energy rating 13 kJ/kV <sub>MCOV</sub>
1	... 1 unit
-4	... Alternating sheds

#### Dimensions 3EJ3 IEEE

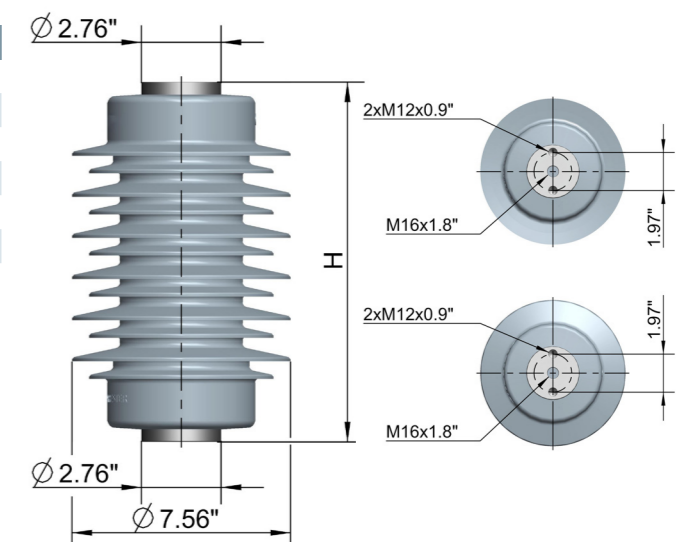

### 3EJ4 specifications according to IEC 60099-4 standard

#### Electrical Characteristics

Rated voltage $U_r$ kV	Continuous operating voltage $U_c$ kV	Arrester type	Designation	Nominal discharge current $I_n$ kA	Charge transfer rating $Q_{15}$ C	Thermal energy rating $W_{th}$ kJ/kV <sub>r</sub>	Maximum values of the residual voltages at discharge currents of the following impulses						
							30/60μs 125 A kV	30/60μs 500 A kV	8/20μs 1 kA kV	8/20μs 3 kA kV	8/20μs 5 kA kV	8/20μs 10 kA kV	8/20μs 20 kA kV
3.3	2.4	3EJ4 003 - 0 C B 8 1 - 4	SH	20	6.0	18.0	5.6	5.9	6.1	6.4	6.7	7.0	7.6
6.5	4.8	3EJ4 006 - 0 C B 8 1 - 4	SH	20	6.0	18.0	11.2	11.7	12.2	12.9	13.3	14.0	15.1
9.0	7.2	3EJ4 009 - 0 C C 8 1 - 4	SH	20	6.0	18.0	15.5	16.3	16.8	17.8	18.4	19.4	20.9
10.5	8.4	3EJ4 010 - 5 C C 8 1 - 4	SH	20	6.0	18.0	18.1	19.0	19.6	20.8	21.5	22.6	24.4
12	9.6	3EJ4 012 - 0 C C 8 1 - 4	SH	20	6.0	18.0	20.6	21.7	22.4	23.7	24.5	25.8	27.9
15	12.0	3EJ4 015 - 0 C D 8 1 - 4	SH	20	6.0	18.0	25.8	27.1	28.1	29.7	30.6	32.3	34.8
18	14.4	3EJ4 018 - 0 C D 8 1 - 4	SH	20	6.0	18.0	31.0	32.5	33.7	35.6	36.8	38.7	41.8
21	16.8	3EJ4 021 - 0 C D 8 1 - 4	SH	20	6.0	18.0	36.1	37.9	39.3	41.5	42.9	45.2	48.8
24	19.2	3EJ4 024 - 0 C E 8 1 - 4	SH	20	6.0	18.0	41.3	43.3	44.9	47.5	49.0	51.6	55.7
27	21.6	3EJ4 027 - 0 C E 8 1 - 4	SH	20	6.0	18.0	46.4	48.8	50.5	53.4	55.2	58.1	62.7
30	24.0	3EJ4 030 - 0 C F 8 1 - 4	SH	20	6.0	18.0	51.6	54.2	56.1	59.3	61.3	64.5	69.7
36	28.8	3EJ4 036 - 0 C G 8 1 - 4	SH	20	6.0	18.0	61.9	65.0	67.3	71.2	73.5	77.4	83.6
42	33.6	3EJ4 042 - 0 C G 8 1 - 4	SH	20	6.0	18.0	72.2	75.9	78.5	83.1	85.8	90.3	97.5
45	36.0	3EJ4 045 - 0 C H 8 1 - 4	SH	20	6.0	18.0	77.4	81.3	84.2	89.0	91.9	96.8	104
48	38.4	3EJ4 048 - 0 C H 8 1 - 4	SH	20	6.0	18.0	82.4	86.5	89.6	94.8	97.9	103	111
51	40.8	3EJ4 051 - 0 C J 8 1 - 4	SH	20	6.0	18.0	88.0	92.4	95.7	101	105	110	119
54	43.2	3EJ4 054 - 0 C J 8 1 - 4	SH	20	6.0	18.0	92.8	97.4	101	107	110	116	125

#### Mechanical Characteristics

Height [H] mm	Creepage distance mm	Rated short-circuit current $I_s$ kA	Lightning impulse withstand voltage 1.2/50μs kV	Power frequency withstand voltage, wet 1 min. kV	Specified short-term load SSL N	Specified long-term load SLL N	Approximate weight of arrester without accessories kg	Flashover distance mm
188	460	50	120	55	10630	7440	7.8	210
188	460	50	120	55	10630	7440	8.7	210
232	660	50	140	65	8620	6030	10.0	253
232	660	50	140	65	8620	6030	10.4	253
232	660	50	140	65	8620	6030	10.9	253
276	850	50	165	75	7240	5070	12.6	296
276	850	50	165	75	7240	5070	13.1	296
276	850	50	165	75	7240	5070	14.0	296
320	1040	50	190	90	6250	4370	15.7	339
320	1040	50	190	90	6250	4370	16.6	339
364	1230	50	215	100	5490	3840	18.3	381
408	1420	50	245	110	4900	3430	20.0	424
408	1420	50	245	110	4900	3430	21.8	424
452	1610	50	270	125	4420	3090	23.5	467
452	1610	50	270	125	4420	3090	24.4	467
496	1810	50	295	135	4030	2820	26.2	509
496	1810	50	295	135	4030	2820	27.1	509

#### How to order

##### 3EJ4 IEC

Example 3EJ4 010-5CC8 1-4	
3EJ4	... with very high energy discharge capability
010-5	... Rated voltage = 10.5 kV
C	... IEC
C	... Housing type (H=232 mm)
3	... Switching surge energy rating 9 kJ/kV <sub>MCCV</sub>
1	... 1 unit
-4	... Alternating sheds

#### Dimensions 3EJ4 IEC

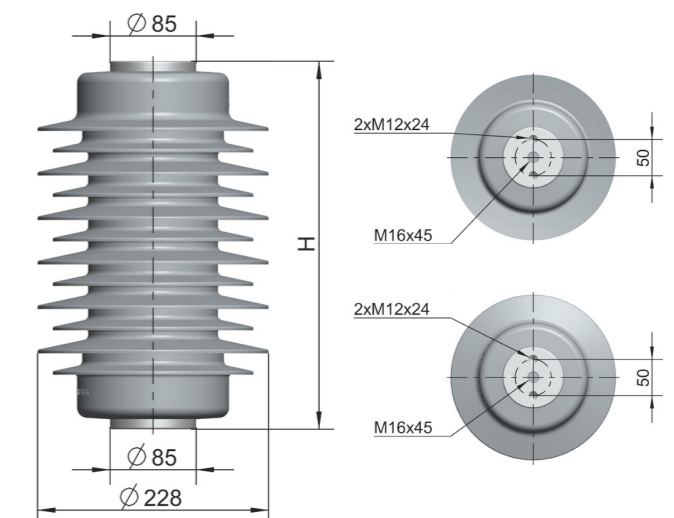

### 3EJ4 specifications according to IEEE C62.11 standard

#### Electrical Characteristics

Duty cycle voltage $U_r$ kV	MCOV $U_c$ kV	Arrester type	Energy class	Lightning impulse classifying current $I_{in}$ kA	Switching surge energy rating kJ/kV <sub>MCOV</sub>	Single impulse withstand rating C	Protective Level Maximum discharge voltage							
							45/90µs 125 A kV cr	45/90µs 500 A kV cr	8/20µs 1.5 kA kV cr	8/20µs 3 kA kV cr	8/20µs 5 kA kV cr	8/20µs 10 kA kV cr	8/20µs 20 kA kV cr	
3.3	2.60	3EJ4 003 - 0 A B 8 1 - 4	K	20	21.0	6.0	5.6	5.9	6.2	6.4	6.7	7.0	7.6	
6.5	5.10	3EJ4 006 - 0 A B 8 1 - 4	K	20	21.0	6.0	11.2	11.7	12.4	12.9	13.3	14.0	15.1	
9.0	7.65	3EJ4 009 - 0 A C 8 1 - 4	K	20	21.0	6.0	15.5	16.3	17.2	17.8	18.4	19.4	20.9	
10	8.40	3EJ4 010 - 0 A C 8 1 - 4	K	20	21.0	6.0	17.2	18.1	19.1	19.8	20.4	21.5	23.2	
12	10.2	3EJ4 012 - 0 A C 8 1 - 4	K	20	21.0	6.0	20.6	21.7	23.0	23.7	24.5	25.8	27.9	
15	12.7	3EJ4 015 - 0 A D 8 1 - 4	K	20	21.0	6.0	25.8	27.1	28.7	29.7	30.6	32.3	34.8	
18	15.3	3EJ4 018 - 0 A D 8 1 - 4	K	20	21.0	6.0	31.0	32.5	34.4	35.6	36.8	38.7	41.8	
21	17.0	3EJ4 021 - 0 A D 8 1 - 4	K	20	21.0	6.0	36.1	37.9	40.2	41.5	42.9	45.2	48.8	
24	19.5	3EJ4 024 - 0 A E 8 1 - 4	K	20	21.0	6.0	41.3	43.3	45.9	47.5	49.0	51.6	55.7	
27	22.0	3EJ4 027 - 0 A E 8 1 - 4	K	20	21.0	6.0	46.4	48.8	51.7	53.4	55.2	58.1	62.7	
30	24.4	3EJ4 030 - 0 A F 8 1 - 4	K	20	21.0	6.0	51.6	54.2	57.4	59.3	61.3	64.5	69.7	
36	29.0	3EJ4 036 - 0 A G 8 1 - 4	K	20	21.0	6.0	61.9	65.0	68.9	71.2	73.5	77.4	83.6	

#### Mechanical Characteristics

Height [H] inch	Leakage distance inch	Rated short-circuit current $I_s$ kA	Recommended minimum clearances		Maximum design cantilever load MDCL lbf	Specified short-term load SSL lbf	Approximate weight of arrester without accessories lbs
			To ground (ph-gnd) inch	Between phases (ph-ph) inch			
7.4	19.0	50	6	10	1674	2392	17.2
7.4	19.0	50	6	10	1674	2392	19.2
9.1	26.8	50	8	12	1356	1938	22.0
9.1	26.8	50	8	12	1356	1938	22.9
9.1	26.8	50	8	12	1356	1938	24.0
10.9	34.6	50	10	14	1140	1629	27.8
10.9	34.6	50	10	14	1140	1629	28.9
10.9	34.6	50	10	14	1140	1629	30.9
12.6	42.4	50	12	17	983	1405	34.6
12.6	42.4	50	12	17	983	1405	36.6
14.3	50.1	50	12	17	864	1235	40.3
16.1	57.9	50	15	20	771	1102	44.1

#### How to order

##### 3EJ4 IEEE

Example 3EJ4 010-0AC81-4	
3EJ4	... with very high energy discharge capability
010-0	... Rated voltage = 10.0 kV
A	... IEEE
C	... Housing type (H=232 mm)
8	... Switching surge energy rating 21 kJ/kV <sub>MCOV</sub>
1	... 1 unit
-4	... Alternating sheds

#### Dimensions 3EJ4 IEEE

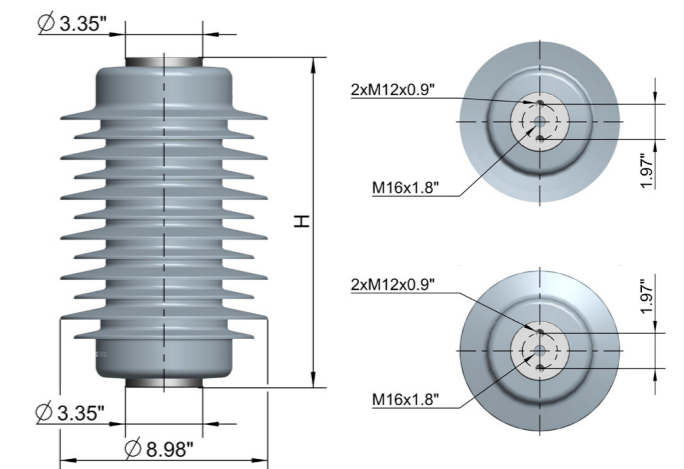

### 3EJ4 indoor version specifications according to IEC 60099-4 standard

#### Electrical Characteristics

Rated voltage $U_r$ kV	Continu-ous operating voltage $U_c$ kV	Arrester type	Designation	Nominal discharge current $I_n$ kA	Charge transfer rating $Q_{15}$ C	Thermal energy rating $W_{th}$ kJ/kV <sub>r</sub>	Maximum values of the residual voltages at discharge currents of the following impulses						
							30/60µs 125 A kV	30/60µs 500 A kV	8/20µs 1 kA kV	8/20µs 3 kA kV	8/20µs 5 kA kV	8/20µs 10 kA kV	8/20µs 20 kA kV
3.3	2.4	3EJ4 003 - 0 C B 8 1 - 0	SH	20	6.0	18.0	5.6	5.9	6.1	6.4	6.7	7.0	7.6
6.5	4.8	3EJ4 006 - 0 C B 8 1 - 0	SH	20	6.0	18.0	11.2	11.7	12.2	12.9	13.3	14.0	15.1
9.0	7.2	3EJ4 009 - 0 C C 8 1 - 0	SH	20	6.0	18.0	15.5	16.3	16.8	17.8	18.4	19.4	20.9
10.5	8.4	3EJ4 010 - 5 C C 8 1 - 0	SH	20	6.0	18.0	18.1	19.0	19.6	20.8	21.5	22.6	24.4
12	9.6	3EJ4 012 - 0 C C 8 1 - 0	SH	20	6.0	18.0	20.6	21.7	22.4	23.7	24.5	25.8	27.9
15	12.0	3EJ4 015 - 0 C D 8 1 - 0	SH	20	6.0	18.0	25.8	27.1	28.1	29.7	30.6	32.3	34.8
18	14.4	3EJ4 018 - 0 C D 8 1 - 0	SH	20	6.0	18.0	31.0	32.5	33.7	35.6	36.8	38.7	41.8
21	16.8	3EJ4 021 - 0 C D 8 1 - 0	SH	20	6.0	18.0	36.1	37.9	39.3	41.5	42.9	45.2	48.8
24	19.2	3EJ4 024 - 0 C E 8 1 - 0	SH	20	6.0	18.0	41.3	43.3	44.9	47.5	49.0	51.6	55.7
27	21.6	3EJ4 027 - 0 C E 8 1 - 0	SH	20	6.0	18.0	46.4	48.8	50.5	53.4	55.2	58.1	62.7
30	24.0	3EJ4 030 - 0 C F 8 1 - 0	SH	20	6.0	18.0	51.6	54.2	56.1	59.3	61.3	64.5	69.7

#### Mechanical Characteristics

Height [H]	Creepage distance	Rated short-circuit current	Lightning impulse withstand voltage	Power frequency withstand voltage, wet	Specified short-term load SSL	Specified long-term load SLL	Approximate weight of arrester without accessories	Flashover distance
mm	mm	$I_s$ kA	1.2/50µs kV	1 min. kV	N	N	kg	mm
188	220	50	120	55	10630	7440	6.9	200
188	220	50	120	55	10630	7440	7.4	200
232	260	50	140	65	8620	6030	8.7	240
232	260	50	140	65	8620	6030	9.1	240
232	260	50	140	65	8620	6030	9.6	240
276	310	50	165	75	7240	5070	10.9	285
276	310	50	165	75	7240	5070	11.3	285
276	310	50	165	75	7240	5070	12.2	285
320	350	50	190	90	6250	4370	13.5	325
320	350	50	190	90	6250	4370	14.4	325
364	390	50	215	100	5490	3840	15.8	370

#### How to order

##### 3EJ4 indoor IEC

Example 3EJ4 010-5CC8 1-0	
3EJ4	... with very high energy discharge capability
010-5	... Rated voltage = 10.5 kV
C	... IEC
C	... Housing type (H=232 mm)
8	... Switching surge energy rating 18 kJ/kV <sub>MCDV</sub>
1	... 1 unit
-0	... shedless

#### Dimensions 3EJ4 indoor IEC

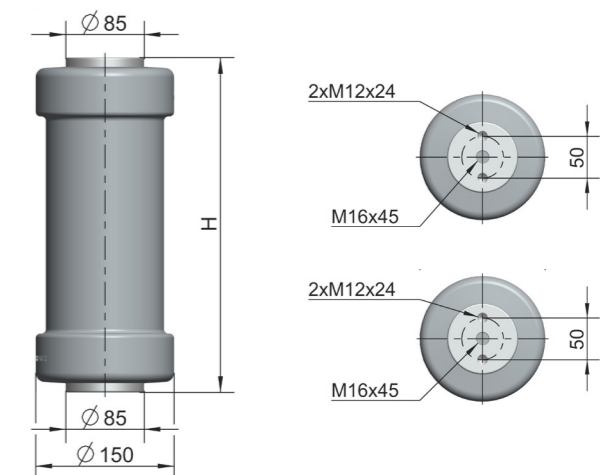

### 3EJ4 indoor version specifications according to IEEE C62.11 standard

**Electrical Characteristics**

Duty cycle voltage $U_r$ kV	MCOV $U_c$ kV	Arrester type	Energy class	Lightning impulse classifying current $I_{in}$ kA	Switching surge energy rating kJ/kV <sub>MCOV</sub>	Single impulse withstand rating C	Protective Level Maximum discharge voltage						
							45/90µs 125 A kV cr	45/90µs 500 A kV cr	8/20µs 1.5 kA kV cr	8/20µs 3 kA kV cr	8/20µs 5 kA kV cr	8/20µs 10 kA kV cr	8/20µs 20 kA kV cr
3	2.6	3EJ4 003 - 0 A B 8 1 - 0	K	20	21.0	6.0	5.2	5.4	5.7	5.9	6.1	6.5	7.0
6	5.1	3EJ4 006 - 0 A B 8 1 - 0	K	20	21.0	6.0	10.3	10.8	11.5	11.9	12.3	12.9	13.9
9	7.7	3EJ4 009 - 0 A C 8 1 - 0	K	20	21.0	6.0	15.5	16.3	17.2	17.8	18.4	19.4	20.9
10	8.4	3EJ4 010 - 0 A C 8 1 - 0	K	20	21.0	6.0	17.2	18.1	19.1	19.8	20.4	21.5	23.2
12	10.2	3EJ4 012 - 0 A C 8 1 - 0	K	20	21.0	6.0	20.6	21.7	23.0	23.7	24.5	25.8	27.9
15	12.7	3EJ4 015 - 0 A D 8 1 - 0	K	20	21.0	6.0	25.8	27.1	28.7	29.7	30.6	32.3	34.8
18	15.3	3EJ4 018 - 0 A D 8 1 - 0	K	20	21.0	6.0	31.0	32.5	34.4	35.6	36.8	38.7	41.8
21	17.0	3EJ4 021 - 0 A D 8 1 - 0	K	20	21.0	6.0	36.1	37.9	40.2	41.5	42.9	45.2	48.8
24	19.5	3EJ4 024 - 0 A E 8 1 - 0	K	20	21.0	6.0	41.3	43.3	45.9	47.5	49.0	51.6	55.7
27	22.0	3EJ4 027 - 0 A E 8 1 - 0	K	20	21.0	6.0	46.4	48.8	51.7	53.4	55.2	58.1	62.7
30	24.4	3EJ4 030 - 0 A F 8 1 - 0	K	20	21.0	6.0	51.6	54.2	57.4	59.3	61.3	64.5	69.7

**Mechanical Characteristics**

Height [H] inch	Leakage distance inch	Rated short-circuit current $I_s$ kA	Recommended minimum clearances		Maximum design cantilever load MDCL lbf	Specified short-term load SSL lbf	Approximate weight of arrester without accessories lbs
			To ground (ph-gnd) inch	Between phases (ph-ph) inch			
7.4	9.3	50	6	10	1674	2392	15.2
7.4	9.3	50	6	10	1674	2392	17.2
9.1	11.0	50	8	12	1357	1938	19.2
9.1	11.0	50	8	12	1357	1938	20.1
9.1	11.0	50	8	12	1357	1938	21.2
10.9	12.7	50	10	14	1140	1629	24.0
10.9	12.7	50	10	14	1140	1629	24.9
10.9	12.7	50	10	14	1140	1629	26.9
12.6	14.4	50	12	17	984	1405	29.8
12.6	14.4	50	12	17	984	1405	31.7
14.3	16.2	50	12	17	865	1235	34.8

#### How to order

**3EJ4 indoor IEEE**

Example 3EJ4 010-0AC81-0	
3EJ4	... with very high energy discharge capability
010-0	... Rated voltage = 10.0 kV
A	... IEEE
C	... Housing type (H=232 mm)
8	... Switching surge energy rating 21 kJ/kV <sub>MCOV</sub>
1	... 1 unit
-0	... Shedless

#### Dimensions 3EJ4 indoor IEEE

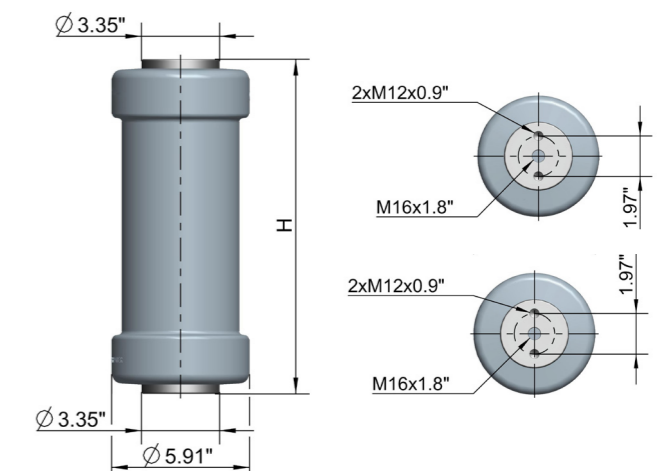

### 3EJ0 specifications according to IEC 60099-4 standard

#### Electrical Characteristics

Rated voltage $U_r$ kV	Continuous operating voltage $U_c$ kV	Arrester type	Designation	Nominal discharge current $I_{in}$ kA	Charge transfer rating $Q_{15}$ C	Thermal charge transfer rating $Q_{th}$ C	Thermal energy rating $W_{th}$ kJ/kV <sub>r</sub>	Maximum values of the residual voltages at discharge currents of the following impulses					
								30/60 $\mu$ s 125 A kV	30/60 $\mu$ s 250 A kV	30/60 $\mu$ s 500 A kV	30/60 $\mu$ s 1 kA kV	8/20 $\mu$ s 5 kA kV	8/20 $\mu$ s 10 kA kV
3.6	3.2	3EJ0 003 - 6 C B 7 1 - 0	DM	5	0.5	1.1	1.0	7.7	7.9	8.0	8.4	9.8	10.5
4.8	4.3	3EJ0 004 - 8 C B 7 1 - 0	DM	5	0.5	1.1	1.0	9.6	9.8	10.0	10.5	12.2	13.1
7.2	6.5	3EJ0 007 - 2 C B 7 1 - 0	DM	5	0.5	1.1	1.0	14.5	14.9	15.0	15.8	18.4	19.8
12	10.6	3EJ0 012 - 0 C C 7 1 - 0	DM	5	0.5	1.1	1.0	24.0	24.7	25.0	26.3	30.6	32.9
15	13.3	3EJ0 015 - 0 C C 7 1 - 0	DM	5	0.5	1.1	1.0	29.8	30.6	31.0	32.6	37.9	40.8

#### Mechanical Characteristics

Height [H]	Creepage distance	Rated short-circuit current	Lightning impulse withstand voltage	Power frequency withstand voltage, wet	Specified short-term load SSL	Specified long-term load SLL	Approximate weight of arrester without accessories	Flashover distance
mm	mm	$I_s$ kA	1.2/50 $\mu$ s kV	1 min. kV	N	N	kg	mm
170	162	20	93	51	2940	2050	0.5	161
170	162	20	93	51	2940	2050	0.6	161
170	162	20	93	51	2940	2050	0.7	161
200	191	20	110	60	2500	1750	1.0	190
200	191	20	110	60	2500	1750	1.2	190

#### How to order

##### 3EJ0 IEC

##### Example 3EJ0 007-2CB71-0

3EJ0	... with very low protection levels
007-2	... Rated voltage = 7.2 kV
C	... IEC
B	... Housing type (H=170 mm)
7	... Energy class $W_{th} = 1$ kJ/kV <sub>r</sub>
1	... 1 unit
-0	... Shedless

#### Dimensions 3EJ0 IEC

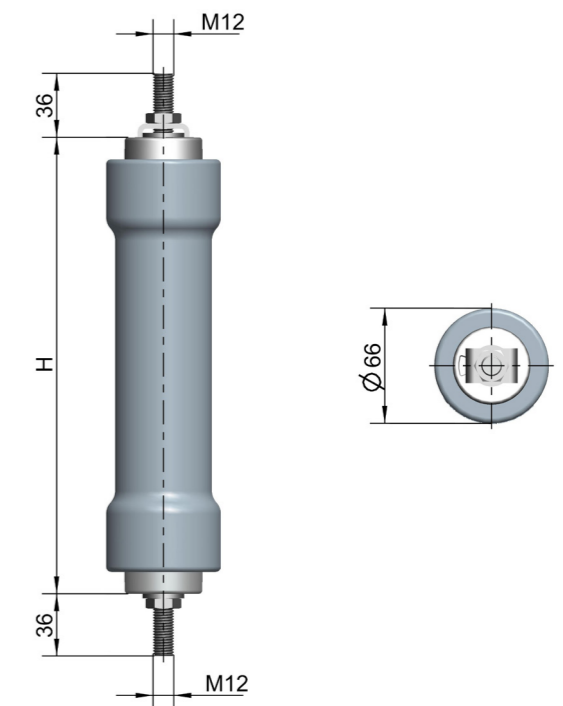

### 3EJ9 specifications according to IEC 60099-4 standard

#### Electrical Characteristics

Rated voltage $U_r$ kV	Continuous operating voltage $U_c$ kV	Arrester type	Designation	Nominal discharge current $I_n$ kA	Charge transfer rating $Q_{rs}$ C	Thermal energy rating $W_{th}$ kJ/kV <sub>r</sub>	Maximum values of the residual voltages at discharge currents of the following impulses					
							30/60μs 125 A kV	30/60μs 250 A kV	30/60μs 500 A kV	30/60μs 1 kA kV	8/20μs 5 kA kV	8/20μs 10 kA kV
3.6	3.2	3EJ9 003 - 6 C B 3 1 - 4A	SM	10	2.0	4.0	7.6	7.8	8.0	8.2	9.4	10.0
4.8	4.3	3EJ9 004 - 8 C B 3 1 - 4A	SM	10	2.0	4.0	9.5	9.8	10.0	10.3	11.8	12.5
7.2	6.5	3EJ9 007 - 2 C C 3 1 - 4A	SM	10	2.0	4.0	14.3	14.7	15.0	15.4	17.7	18.8
7.2	6.5	3EJ9 007 - 2 C B 7 1 - 4B	SH	20	6.0	4.0	12.0	12.3	12.6	12.9	14.3	15.0
12	10.6	3EJ9 012 - 0 C C 3 1 - 4A	SM	10	2.0	4.0	23.7	24.3	25.0	25.6	29.3	31.2
12	10.6	3EJ9 012 - 0 C C 7 1 - 4B	SH	20	6.0	4.0	19.5	20.0	20.5	21.0	23.2	24.4

#### Mechanical Characteristics

Height [H] mm	Creepage distance mm	Rated short-circuit current $I_s$ kA	Lightning impulse withstand voltage 1.2/50μs kV	Power frequency withstand voltage, wet 1 min. kV	Specified short-term load SSL N	Specified long-term load SLL N	Approximate weight of arrester without accessories kg	Flashover distance mm
166	430	50	100	45	6020	4210	3.3	173
166	430	50	100	45	6020	4210	3.4	173
211	590	50	125	60	4730	3310	4.1	218
188	460	50	120	55	10630	7440	8.7	210
211	590	50	125	60	4730	3310	4.7	218
232	660	50	140	65	8620	6030	10.9	253

### 3EJ9 indoor version specifications according to IEC 60099-4 standard

#### Electrical Characteristics

Rated voltage $U_r$ kV	Continuous operating voltage $U_c$ kV	Arrester type	Designation	Nominal discharge current $I_n$ kA	Charge transfer rating $Q_{rs}$ C	Thermal energy rating $W_{th}$ kJ/kV <sub>r</sub>	Maximum values of the residual voltages at discharge currents of the following impulses					
							30/60μs 125 A kV	30/60μs 250 A kV	30/60μs 500 A kV	30/60μs 1 kA kV	8/20μs 5 kA kV	8/20μs 10 kA kV
7.2	6.5	3EJ9 007 - 2 C B 7 1 - 0B	SH	20	6.0	4.0	12.0	12.3	12.6	12.9	14.3	15.0
12	10.6	3EJ9 012 - 0 C C 7 1 - 0B	SH	20	6.0	4.0	19.5	20.0	20.5	21.0	23.2	24.4

#### Mechanical Characteristics

Height [H] mm	Creepage distance mm	Rated short-circuit current $I_s$ kA	Lightning impulse withstand voltage 1.2/50μs kV	Power frequency withstand voltage, wet 1 min. kV	Specified short-term load SSL N	Specified long-term load SLL N	Approximate weight of arrester without accessories kg	Flashover distance mm
188	220	50	120	55	10630	7440	7.8	200
232	260	50	140	65	8620	6030	9.6	240

#### How to order

##### 3EJ9 IEC

##### Example 3EJ9 007-2CC3 1-4A

3EJ9	... with very low protection levels
007-2	... Rated voltage = 7.2 kV
C	... IEC
B	... Housing type (H=211 mm)
7	... Energy class $W_{th} = 1$ kJ/kV <sub>r</sub>
1	... 1 unit
-4	... Alternating sheds
A	... in exchange for 3EF3-0

#### Dimensions 3EJ9 IEC -4A

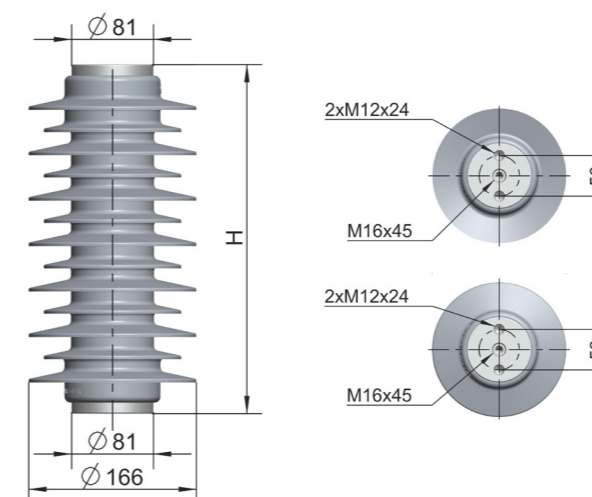

#### Dimensions 3EJ9 IEC -4B

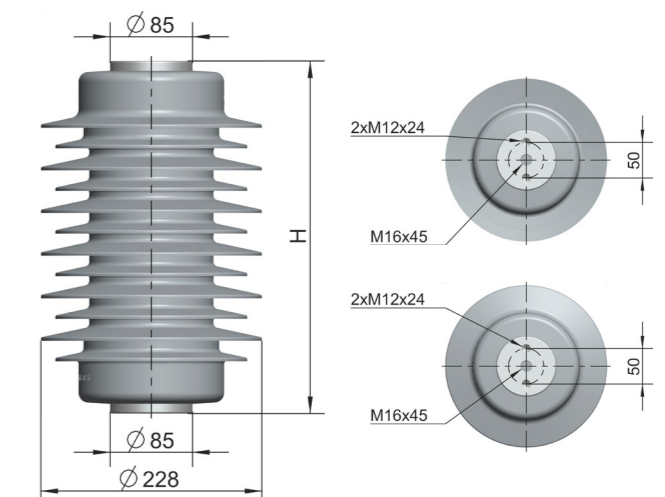

## 3EJ Accessories

### Line terminal options

#### L-bracket

Order number: 3EX4 500-1L

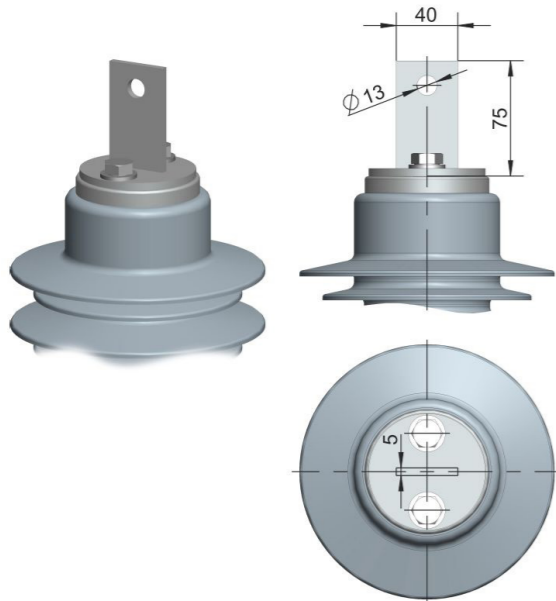

#### Flat DIN/NEMA terminal 40<sup>2</sup> x 50<sup>2</sup> mm

Order number: 3EX4 500-1X

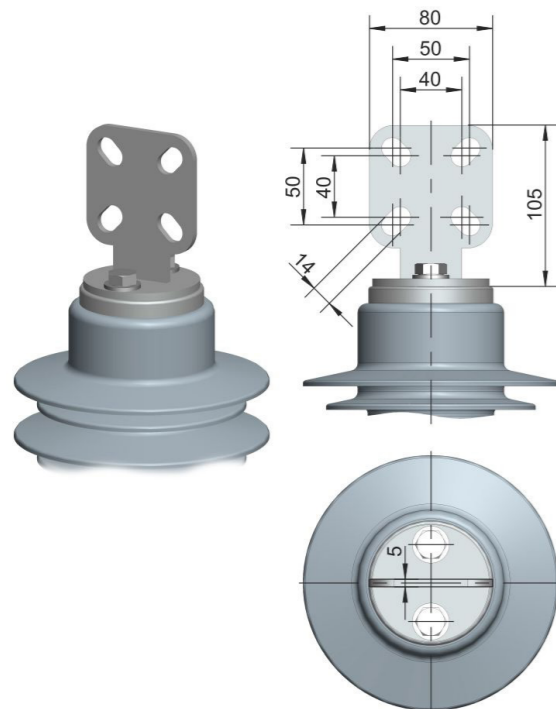

### Mounting options

#### Mounting, insulated, Ø190...260 mm. D=10"

Order number: 3EX4 500-2A

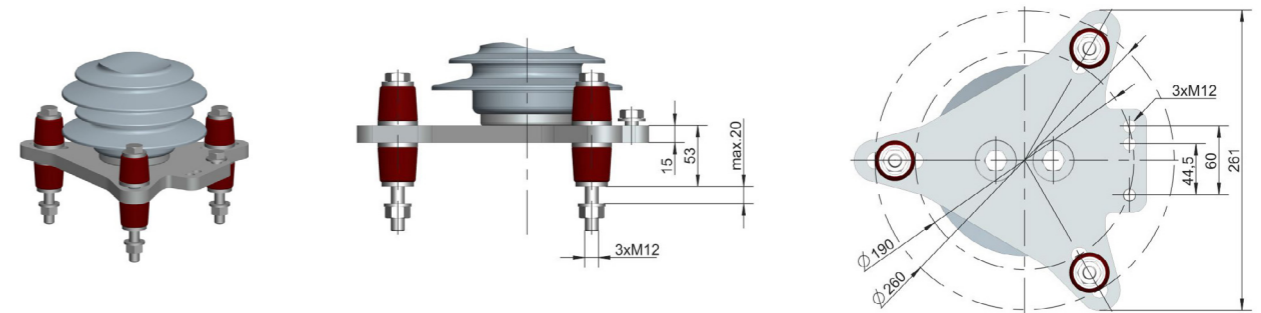

#### Mounting, insulated, 170x170 mm

Order number: 3EX4 500-2B

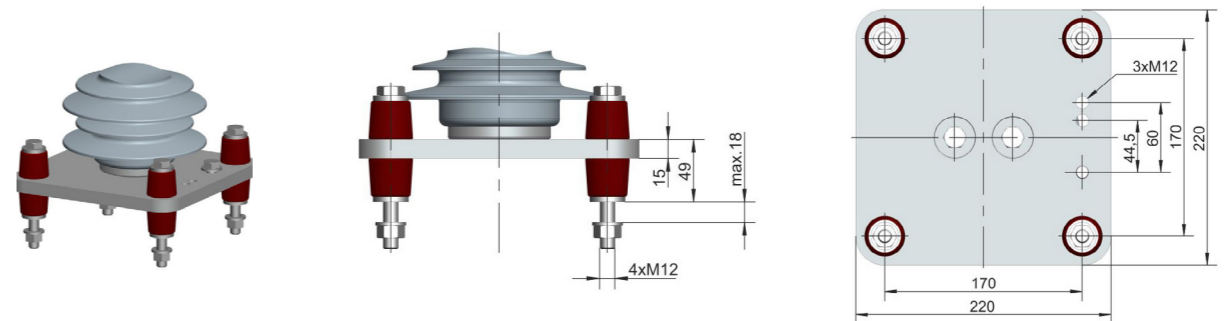

#### Mounting, insulated, 200x200 mm

Order number: 3EX4 500-2C

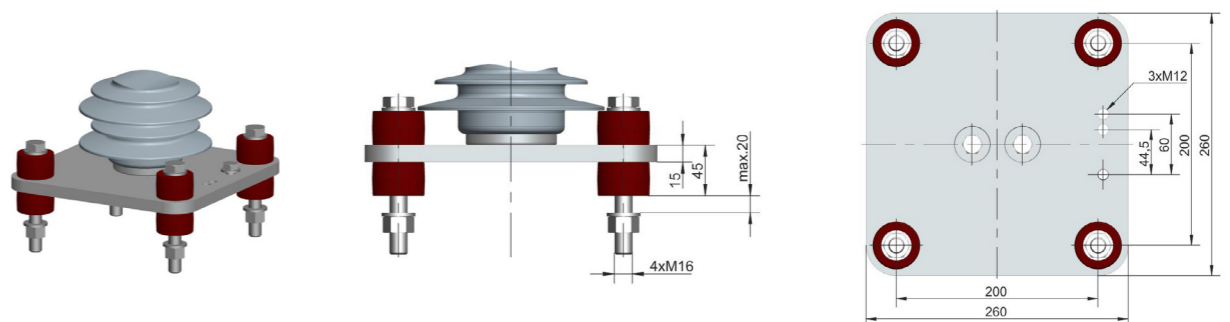

## Mounting options

### Mounting, insulated, 310x310 mm

Order number: 3EX4 500-2D

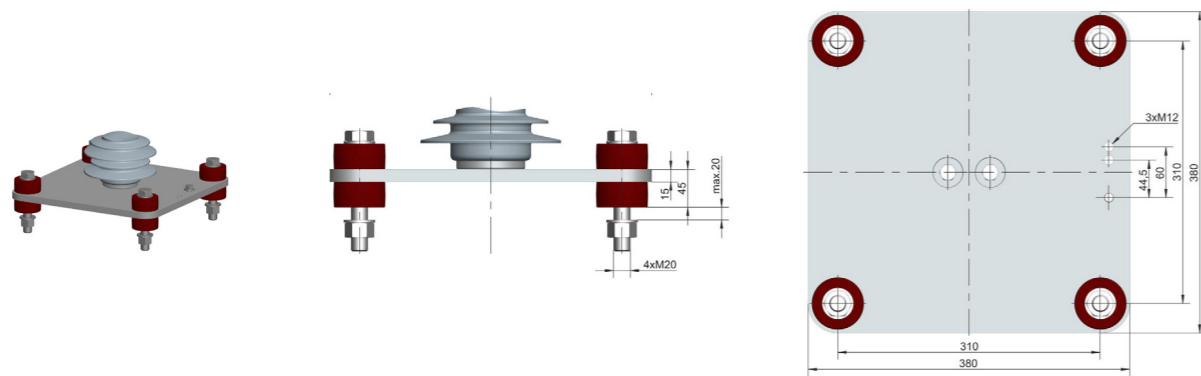

### Mounting, grounded, Ø190...260 mm. D=10"

Order number: 3EX4 500-3A

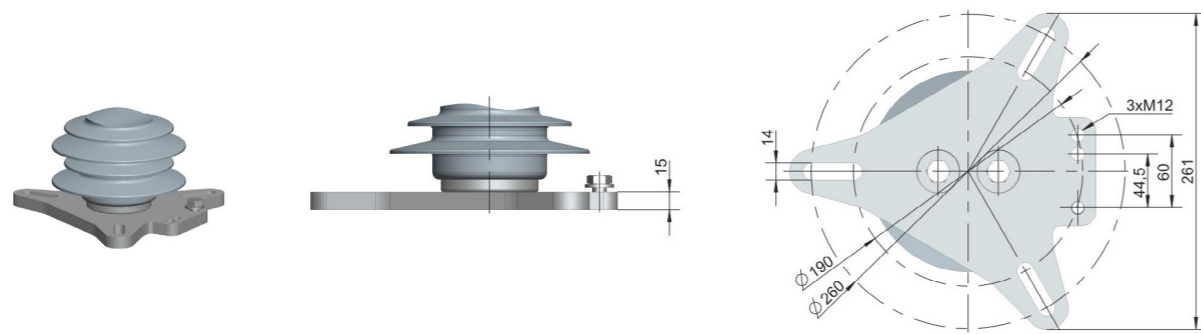

### Mounting, grounded, 170x170 mm

Order number: EX4 500-3B

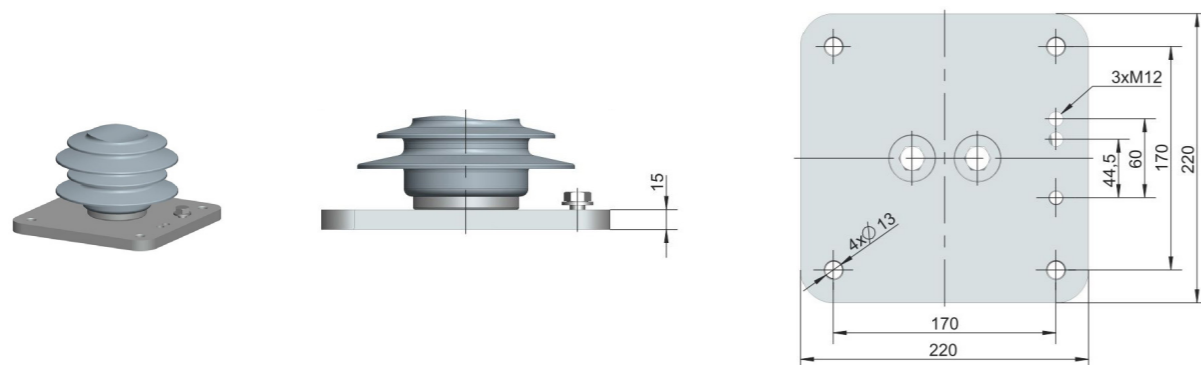

### Mounting, grounded, 200x200 mm

Order number: 3EX4 500-3C

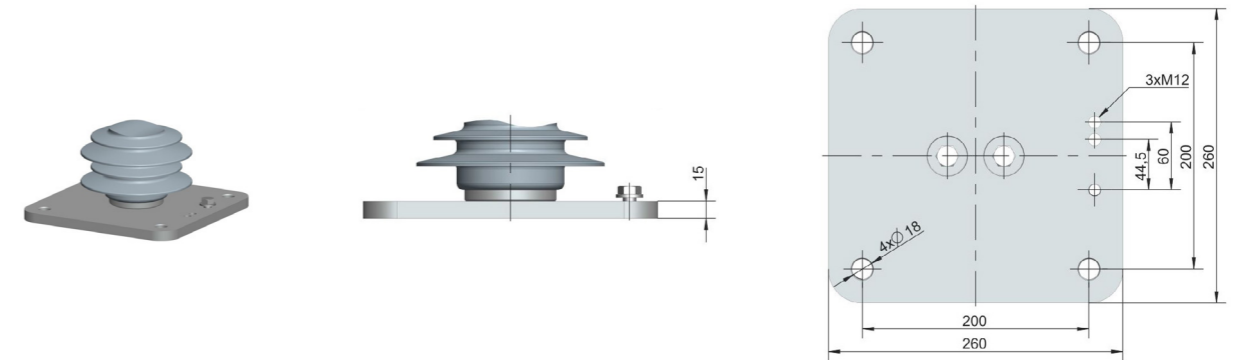

### Mounting, grounded, 310x310 mm

Order number: 3EX4 500-3D

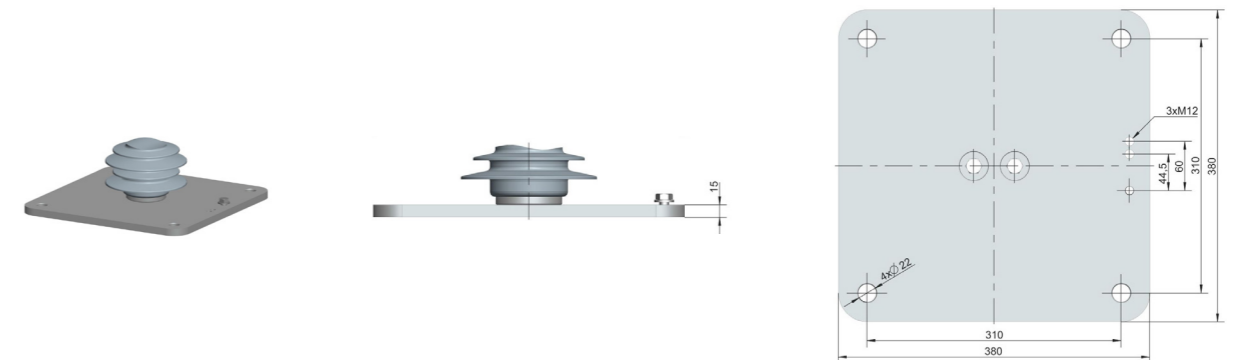

## Packing dimensions 3EJ

Arrester type	Housing	Length		Width		Height	
		mm	inch	mm	inch	mm	inch
3EJ0	Housing B	270	10.6	220	8.7	142	5.6
	Housing C	300	11.8	220	8.7	142	5.6
3EJ2	All housings	290	11.4	280	11.0	560	22.0
3EJ3	All housings	290	11.4	280	11.0	560	22.0
3EJ4	All housings	290	11.4	280	11.0	560	22.0
3EJ9	All housings	290	11.4	280	11.0	560	22.0

# 3EP-G Porcelain surge arresters

Siemens Energy 3EP porcelain-housed surge arresters ensure maximum protection in an overload situation thanks to a specially designed directional pressure relief device.

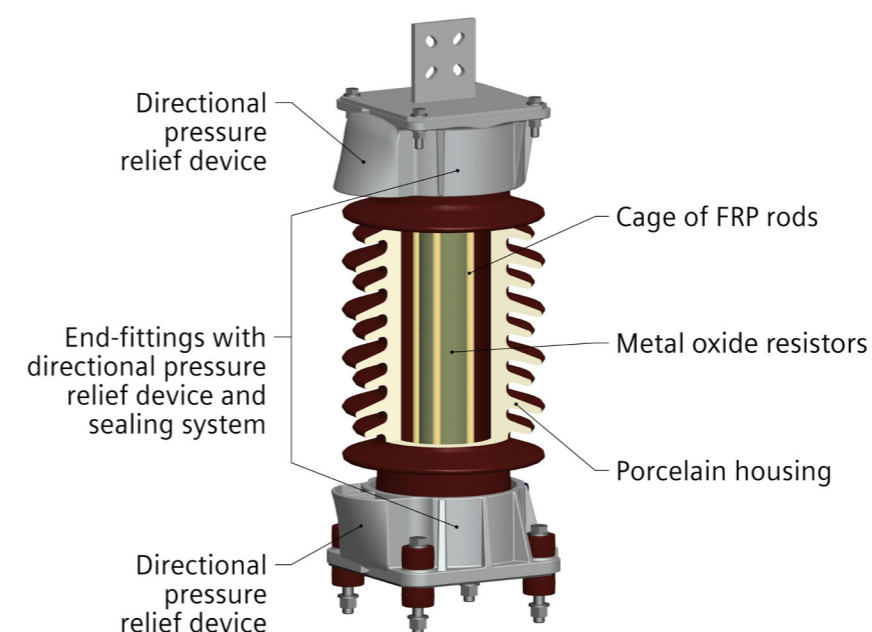

In the case of an overload or the extremely rare case of an arrester short-circuit, the arc escapes easily through the pressure relief devices. No pressure is built up inside the arrester and no internal parts are ejected, which prevents damage to surrounding equipment.

For the overvoltage protection of generators and motors, which require a very high short-circuit current capability, Siemens Energy offers the **3EP-G** porcelain housed surge arresters with short-circuit current capability up to 300 kA.

The excellent sealing system of 3EP-G surge arresters prevents failures or moisture ingress and guarantees decades of trouble-free service. The use of nonporous sulfur

cement instead of corrosive Portland cement for bonding protects the MO resistors and prevents aging effects.

The MO resistors of 3EP-G surge arresters are enclosed by a rigid, reinforced cage made of FRP rods. The high tensile strength of the FRP rods is used to hold the arrester's MO resistors in place tightly.

### 3EP-G specifications according to IEC 60099-4 standard

Electrical Characteristics

Rated voltage $U_r$ kV	Continuous operating voltage $U_c$ kV	Arrester type	Short circuit current $I_s$ kA	Nominal discharge current $I_n$ kA	Charge transfer rating $Q_{rs}$ C	Thermal energy rating $W_{th}$ kJ/kV <sub>r</sub>	Maximum values of the residual voltages at discharge currents of the following impulses							
							30/60µs 125 A kV	30/60µs 500 A kV	8/20µs 1 kA kV	8/20µs 3 kA kV	8/20µs 5 kA kV	8/20µs 10 kA kV	8/20µs 20 kA kV	
3.0	2.4	3EP3 003 - 2 G A 3 1 - 1ZA9-Z K83 P2G R2G	300	10	2.0	7.0	5.4	5.6	5.9	6.3	6.6	7.1	7.8	
6.0	4.8	3EP3 006 - 2 G A 3 1 - 1ZA9-Z K83 P2G R2G	300	10	2.0	7.0	10.7	11.3	11.8	12.7	13.3	14.1	15.7	
9.0	7.2	3EP3 009 - 2 G A 3 1 - 1ZA9-Z K83 P2G R2G	300	10	2.0	7.0	16.1	16.9	17.8	19.0	19.9	21.2	23.5	
12	9.6	3EP3 012 - 2 G A 3 1 - 1ZA9-Z K83 P2G R2G	300	10	2.0	7.0	21.4	22.6	23.7	25.4	26.5	28.2	31.3	
15	12.0	3EP3 015 - 2 G A 3 1 - 1ZA9-Z K83 P2G R2G	300	10	2.0	7.0	26.8	28.2	29.6	31.7	33.1	35.3	39.1	
18	14.4	3EP3 018 - 2 G A 3 1 - 1ZA9-Z K83 P2G R2G	300	10	2.0	7.0	32.1	33.8	35.5	38.1	39.8	42.3	47.0	
21	16.8	3EP3 021 - 2 G A 3 1 - 1ZA9-Z K83 P2G R2G	300	10	2.0	7.0	37.5	39.5	41.5	44.4	46.4	49.4	54.8	
24	19.2	3EP3 024 - 2 G A 3 1 - 1ZA9-Z K83 P2G R2G	300	10	2.0	7.0	42.9	45.1	47.4	50.8	53.0	56.4	62.6	
27	21.6	3EP3 027 - 2 G A 3 1 - 1ZA9-Z K83 P2G R2G	300	10	2.0	7.0	48.2	50.8	53.3	57.1	59.6	63.5	70.4	
30	24.0	3EP3 030 - 2 G A 3 1 - 1ZA9-Z K83 P2G R2G	300	10	2.0	7.0	53.6	56.4	59.2	63.5	66.3	70.5	78.3	
36	28.8	3EP3 036 - 2 G A 3 1 - 1ZA9-Z K83 P2G R2G	300	10	2.0	7.0	64.3	67.7	71.1	76.1	79.5	84.6	93.9	
42	33.6	3EP3 042 - 2 G A 3 1 - 1ZA9-Z K83 P2G R2G	300	10	2.0	7.0	75.0	79.0	82.9	88.8	92.8	98.7	110	
45	36.0	3EP3 045 - 2 G A 3 1 - 1ZA9-Z K83 P2G R2G	300	10	2.0	7.0	80.6	84.8	89.0	95.4	99.6	106	118	
48	38.4	3EP3 048 - 2 G A 3 1 - 1ZA9-Z K83 P2G R2G	300	10	2.0	7.0	85.9	90.4	94.9	102	106	113	125	
51	40.8	3EP3 051 - 2 G A 3 1 - 1ZA9-Z K83 P2G R2G	300	10	2.0	7.0	91.2	96.0	101	108	113	120	133	

Mechanical Characteristics

Height [H]	Creepage distance	Lightning impulse withstand voltage 1.2/50µs kV	Power frequency withstand voltage, wet 1 min. kV	Specified short-term load SSL N	Specified long-term load SLL N	Approximate weight of arrester kg	Flashover distance mm
665	1035	206	78	51120	20450	80.1	350
665	1035	206	78	51120	20450	80.1	350
665	1035	206	78	51120	20450	80.1	350
665	1035	206	78	51120	20450	80.7	350
665	1035	206	78	51120	20450	80.7	350
665	1035	206	78	51120	20450	81.5	350
665	1035	206	78	51120	20450	81.5	350
665	1035	206	78	51120	20450	82.1	350
665	1035	206	78	51120	20450	82.1	350
665	1035	206	78	51120	20450	82.8	350
665	1035	206	78	51120	20450	83.5	350
665	1035	206	78	51120	20450	84.1	350
665	1035	206	78	51120	20450	84.1	350
665	1035	206	78	51120	20450	84.1	350

#### How to order

3EP-G IEC

Example 3EP3 030-2GA31-2ZA9-Z K83 P2G R2G	
3EP3	... Tube design porcelain housing, heavy
007-2	... Rated voltage = 7.2 kV
030	... Rated voltage = 30 kV
-2	... Resistor type
G	... Generator protection
A	... Housing type (H=665 mm)
3	... Energy class $W_{th} = 7$ kJ/kV
1	... 1 unit
-2	... Alternating sheds
Z	... Special high-voltage terminal (see below)
A	... Nameplate (German/English)
9	... Special mounting (see below)
K83	... Enhanced short-circuit performance 300 kA
P2G	... Terminal plate 13 mm for 300 kA
R2G	... Insulated mounting 300 kA

#### Dimensions 3EP3-G IEC

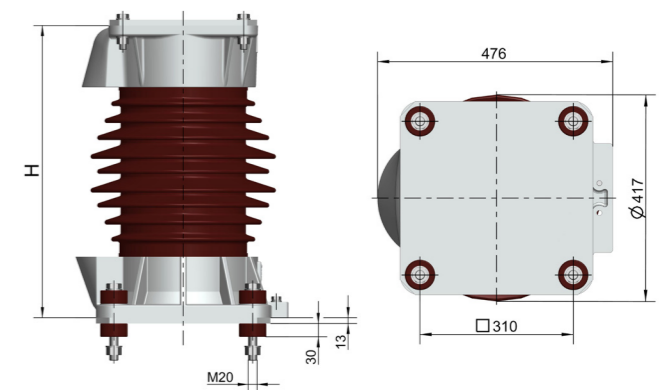

## Packing dimensions 3EP-G

Single packing

Arrester type	Housing	Length		Width		Height	
		mm	inch	mm	inch	mm	inch
3EP-G	3EP3-G, housing A	80	3.1	80	3.1	130	5.1

Triple packing

Arrester type	Housing	Length		Width		Height	
		mm	inch	mm	inch	mm	inch
3EP-G	3EP3-G, housing A	150	5.9	80	3.1	130	5.1

# Glossary

### Continuous operating voltage (symbol $U_c$ )

indicates the designated permissible root mean square value of the power frequency voltage that is allowed to be applied continuously between the arrester terminals.

### Creepage distance

defines the distance between the metal end fittings, measured along the housing surface. It is an important factor in the behavior of an insulator – or a device containing an insulator – in polluted conditions.

### Discharge voltage

quantifies the voltage drop between the arrester’s terminals when a current impulse is injected. For current impulses in the shape and value of a standard test current impulse (lightning current impulse, switching current impulse, steep current impulse), the simultaneously occurring residual voltages define the protective levels that are assigned to this current shape and value.

### Duty cycle voltage (symbol $U_d$ )

is the maximum permissible root mean square value of the power frequency voltage between the arrester terminals at which the arrester is designed to operate correctly under temporary overvoltage conditions as the operating duty tests. Normally, the manufacturer specifies whether it can be applied to the arrester for a duration of 10 seconds (which corresponds to the value in the operating duty test) or 100 seconds. The rated voltage is the reference parameter for determining the operating characteristics.

### Highest voltage of a system (symbol $U_s$ )

indicates the root mean square value of the highest phase-to-phase operating voltage that occurs under normal operating conditions at any time and at any point in the system.

### Leakage distance

defines the distance between the metal end fittings, measured along the housing surface. It is an important factor in the behavior of an insulator – or a device containing an insulator – in polluted conditions.

### Lightning impulse classifying current (symbol $I_n$ )

indicates the peak value of a lightning current impulse used to classify an arrester.

### Maximum Continuous Operating Voltage (MCOV)

indicates the designated permissible root mean square value of the power frequency voltage that is allowed to be applied continuously between the arrester terminals.

### Nominal discharge current (symbol $I_n$ )

indicates the peak value of a lightning current impulse used to classify an arrester.

### Protective level

is the maximum value of an arrester’s residual voltage at a standard current impulse. In this case, there is a difference between the lightning impulse protective level (8/20  $\mu$ s), the switching impulse protective level (30/60  $\mu$ s), and the steep current impulse (1/2 $\mu$ s) protective level.

### Rated short-circuit current (symbol $I_s$ )

indicates the root mean square value of the symmetrical highest short-circuit current that can flow after an arrester has been overloaded without causing violent shattering of the housing.

### Rated voltage (symbol $U_r$ )

is the maximum permissible root mean square value of the power frequency voltage between the arrester terminals at which the arrester is designed to operate correctly under temporary overvoltage conditions as the operating duty tests. Normally, the manufacturer specifies whether it can be applied to the arrester for a duration of 10 seconds (which corresponds to the value in the operating duty test) or 100 seconds. The rated voltage is the reference parameter for determining the operating characteristics.

### Residual voltage

quantifies the voltage drop between the arrester’s terminals when a current impulse is injected. For current impulses in the shape and value of a standard test current impulse (lightning current impulse, switching current impulse, steep current impulse), the simultaneously occurring residual voltages define the protective levels that are assigned to this current shape and value.

### Specific creepage distance (SCD)

is the creepage distance of an insulator in relation to the highest voltage for the equipment,  $U_s$  (phase-to-phase voltage), given in mm/kV.

### Temporary overvoltage (TOV)

denominates the power frequency overvoltage that can occur for a duration of several tenths of a second to up to a few seconds, as a result of a switching operation or system failure. Its value depends on the type of neutral earthing in the system.

## Published by

Siemens Energy Global GmbH & Co. KG  
Grid Technologies  
Siemenspromenade 9  
91058 Erlangen  
Germany

For the U.S. published by  
Siemens Energy, Inc  
Grid Technologies  
4601 Six Forks Road  
Raleigh, NC 27609  
USA

For more information, please visit our website:  
[siemens-energy.com/arresters](https://www.siemens-energy.com/arresters)  
or contact us: [arrester.energy@siemens-energy.com](mailto:arrester.energy@siemens-energy.com)

© Siemens Energy, 2026

Siemens Energy is a trademark licensed by Siemens AG.

Subject to changes and errors. The information given in this document only contains general descriptions and/or performance features which may not always specifically reflect those described, or which may undergo modification in the course of further development of the products. The requested performance features are binding only when they are expressly agreed upon in the concluded contract. All product designations may be trademarks or product names of Siemens Energy Global GmbH & Co. KG or other companies whose use by third parties for their own purposes could violate the rights of the owners.