

3EB5 Surge arresters

with silicone rubber housing and Cage Design™

- 1 Cage of FRP rods
- 2 Metal oxide resistors
- 3 Silicone rubber sheds directly molded on metal oxide resistors and on end-fittings
- 4 End-fittings

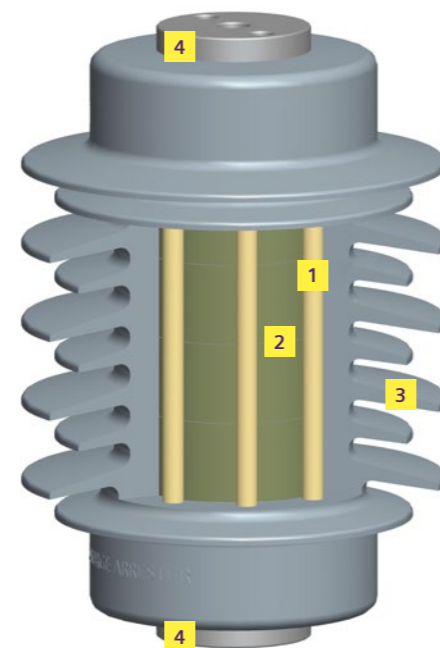

The innovative Cage Design™ of Siemens Energy 3EB5 rail surge arresters ensures high mechanical strength, safe overload performance, and maintenance-free, reliable service: The metal oxide resistors (MOVs) are enclosed by a cage made of fiber-glass reinforced plastic (FRP) rods. This rigid, reinforced structure ensures high mechanical strength. The self-extinguishing and flame retardant silicone rubber housing is directly molded onto the MOVs and the FRP rods for excellent sealing. All components are completely embedded, inclusions and gaps are avoided, partial discharges and moisture are prevented. The hydrophobic silicone rubber is permanently water-repellent and stain-resistant, which results in high tracking and erosion resistance.

Since the MOVs are not enclosed in a sealed mechanical shell, the arc can escape directly through the soft silicone housing in the extremely rare event of the MOVs being overloaded. Arcing cannot lead to critical internal pressure, the mechanical support structure of the enclosure remains unharmed, the ejection of internal parts that could damage other equipment nearby is prevented almost completely.

3EB5 railway surge arresters are suitable for rail vehicles with speeds of up to 320 km/h (200 mph) and for stationary application in areas accessible to the public.

Dimensions

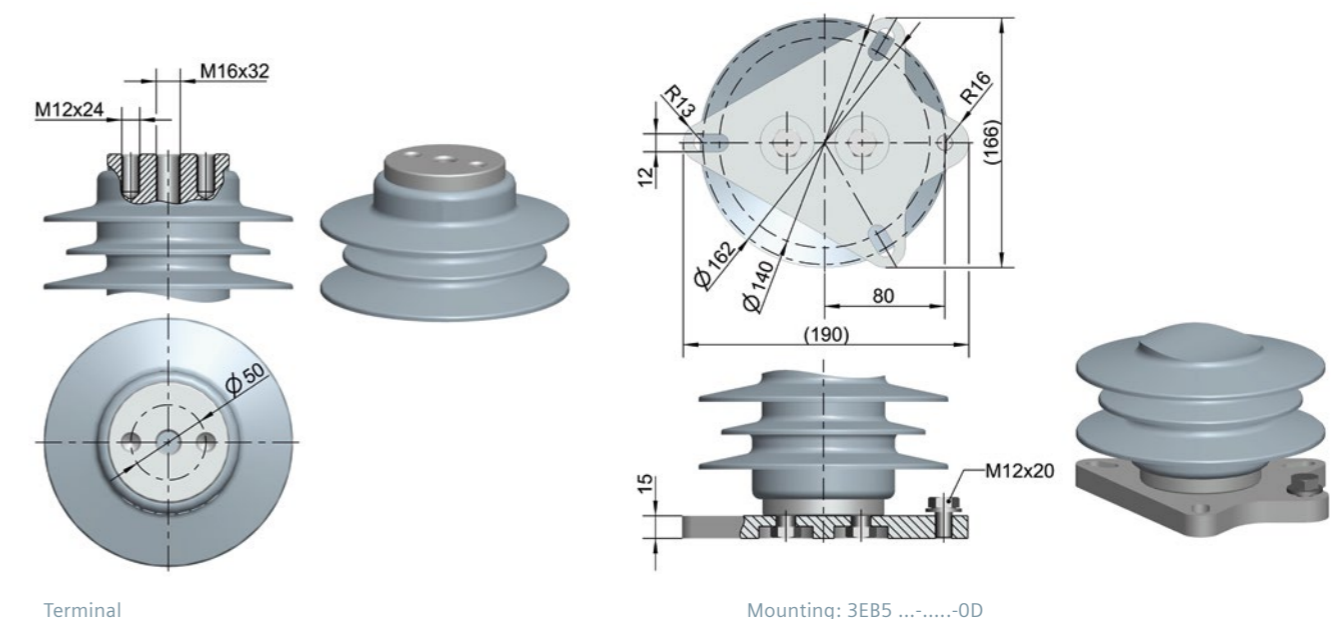
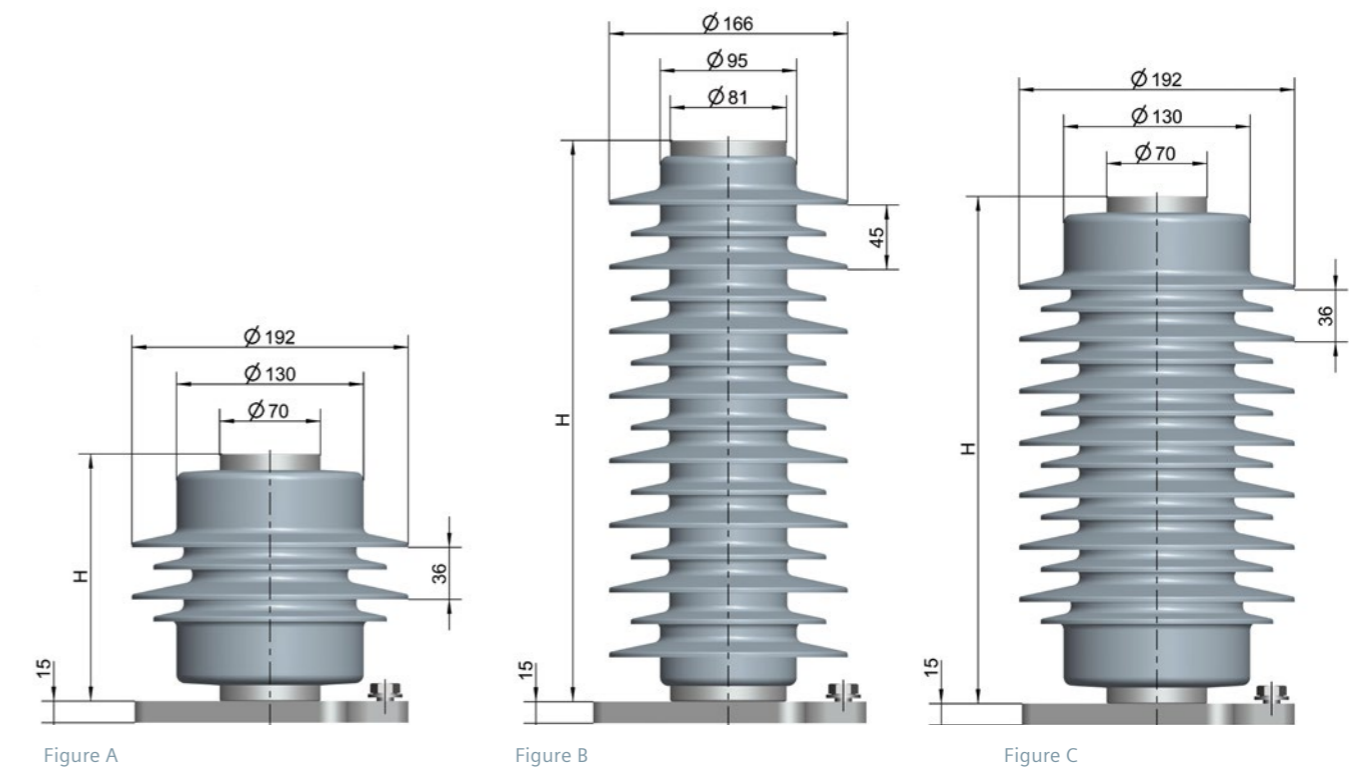

Surge arrester 3EB5

Electrical characteristics

Nominal system voltage	Rated voltage	Continuous operating voltage	Arrester type	Maximum travel speed	Arrester designation	Nominal discharge current	Charge transfer rating	Thermal energy rating	Maximum values of the residual voltages at discharge currents of the following impulses					
									30/60 μs 0.5 kA	30/60 μs 1 kA	30/60 μs 2 kA	8/20 μs 5 kA	8/20 μs 10 kA	8/20 μs 20 kA
U _n kV	U _r kV	U _c kV		km/h		I _n kA	Q _{rs} C	W _{th} kJ						

AC

15	23	18	3EB5 230 - 6 A E 3 0 - OD	320	SM	10	2.0	161	43.2	44.3	46.5	50.8	54.1	60.0
	23	18	3EB5 230 - 7 A E 3 0 - OD	320	SH	20	2.8	230	43.0	44.3	45.5	48.9	51.8	56.4
	23	18	3EB5 230 - 8 A E 3 0 - OD	320	SH	20	3.6	322	43.0	44.3	45.5	48.9	51.8	56.4
25	37	30	3EB5 370 - 6 A G 3 0 - OD	320	SM	10	2.0	259	69.6	71.3	74.8	81.7	87.0	96.5
	37	30	3EB5 370 - 7 A G 3 0 - OD	320	SH	20	2.8	370	69.1	71.2	73.3	78.7	83.3	90.8
	37	30	3EB5 370 - 8 A H 3 0 - OD	320	SH	20	3.6	518	69.1	71.2	73.3	78.7	83.3	90.8
	42	34	3EB5 420 - 6 A G 3 0 - OD	320	SM	10	2.0	294	79.0	80.9	84.9	92.8	98.7	110
	42	34	3EB5 420 - 7 A H 3 0 - OD	320	SH	20	2.8	420	78.5	80.8	83.2	89.3	94.5	103
	42	34	3EB5 420 - 8 A J 3 0 - OD	320	SH	20	3.6	588	78.5	80.8	83.2	89.3	94.5	103
	45	36	3EB5 450 - 6 A H 3 0 - OD	320	SM	10	2.0	315	84.6	86.7	90.9	99.4	106	117
	45	36	3EB5 450 - 7 A J 3 0 - OD	320	SH	20	2.8	450	84.1	86.6	89.1	95.7	101	110
	45	36	3EB5 450 - 8 A J 3 0 - OD	320	SH	20	3.6	630	84.1	86.6	89.1	95.7	101	110

DC

0.75	1.0	1.0	3EB5 010 - 8 D B 3 0 - OD	320	DC-B	20	3.6	14	1.9	1.9	2.0	2.1	2.3	2.5
	1.5	1.5	3EB5 015 - 8 D B 3 0 - OD	320	DC-B	20	3.6	21	2.8	2.9	3.0	3.2	3.4	3.7
1.5	2.0	2.0	3EB5 020 - 8 D B 3 0 - OD	320	DC-B	20	3.6	28	3.7	3.8	4.0	4.3	4.5	4.9
	3.0	3.0	3EB5 030 - 8 D B 3 0 - OD	320	DC-B	20	3.6	42	5.6	5.8	5.9	6.4	6.8	7.4
3.0	4.5	4.5	3EB5 045 - 8 D B 3 0 - OD	320	DC-B	20	3.6	63	8.4	8.7	8.9	9.6	10.1	11.0
	4.8	4.8	3EB5 048 - 8 D B 3 0 - OD	320	DC-B	20	3.6	67	9.0	9.2	9.5	10.2	10.8	11.8

Mechanical characteristics

Height [H]	Creepage distance	Rated short circuit current	Lightning impulse withstand voltage 1.2/50μs	Power frequency withstand voltage 1 min., wet	Specified short-term load SSL	Specified long-term load SLL	Weight of arrester	Flashover distance	Figure
mm	mm	I _s kA	kV	kV	N	N	kg	mm	

301	920	50	175	80	3320	2320	6.4	306	B
281	860	65	165	75	5330	3730	10.1	288	C
281	860	65	165	75	5330	3730	10.1	288	C
391	1250	50	225	105	2550	1790	8.3	394	B
353	1170	65	210	95	4240	2970	13.1	360	C
389	1330	65	230	105	3850	2690	14.1	395	C
391	1250	50	225	105	2550	1790	8.9	394	B
389	1330	65	230	105	3850	2690	14.5	395	C
425	1480	65	250	115	3520	2470	15.6	430	C
436	1420	50	250	120	2290	1600	9.5	438	B
425	1480	65	250	115	3520	2470	15.6	430	C
425	1480	65	250	115	3520	2470	16.0	430	C

172	390	65	105	50	8720	6100	4.9	182	A
172	390	65	105	50	8720	6100	5.0	182	A
172	390	65	105	50	8720	6100	5.1	182	A
172	390	65	105	50	8720	6100	5.2	182	A
172	390	65	105	50	8720	6100	5.5	182	A
172	390	65	105	50	8720	6100	5.5	182	A